

Low and High Voltage Process Performance Motors



ABB

Making you more competitive

ABB's Process performance motor is engineered to the toughest demands of today's process industries. These motors use the best materials and construction methods to achieve the highest quality and reliability, and a possible operating life of over 30 years. The motor design is highly adaptable to allow rapid engineered solution according to customer's specification.



ABB is a global leader in power and automation technologies that enable utility and industry customers to improve their performance while lowering environmental impact. The ABB Group of companies operates in around 100 countries and employs about 107,000 people.

Low and High Voltage Process Performance Motors

Sizes 71 to 450, from 0.25 to 1000 kW

	Contents	Page	
1	General information	4	1
2	Low voltage cast iron motors	13	2
3	Low voltage aluminum motors	69	3
4	Low voltage premium efficiency cast iron and aluminum motors	117	4
5	Motors for high ambient temperatures	123	5
6	High voltage cast iron motors	137	6

ABB reserves the right to change the design, technical specification and dimensions without prior notice.

General information

Standards

ABB motors are of the totally enclosed, three phase squirrel cage type, built to comply with international IEC and EN standards. Motors conforming to other national and international specifications are also available on request.

All production units are certified to ISO 9001 international quality standard as well as ISO 14000 environmental standard and confirm to all applicable EU Directives.

IEC / EN

Electrical	Mechanical
IEC/EN 60034-1	IEC 60072
IEC/EN 60034-2	IEC/EN 60034-5
IEC 60034-8	IEC/EN 60034-6
IEC 60034-12 (for LV only)	IEC/EN 60034-7
	IEC/EN 60034-9
	IEC 60034-14



M000003



M000288



M000004



M000289

Low voltage motors for EU motor efficiency levels

A Europe-wide agreement will ensure that the efficiency levels of electric motors manufactured in Europe are clearly displayed. In contrast to the American legislation on motor efficiency the European agreement does not establish mandatory efficiency levels.

It basically establishes three classes giving motor manufacturers an incentive to qualify for a higher class.

ABB is one of only a handful of leading motor manufacturers in Europe to have a motor range to meet or exceed the minimum efficiencies stated in the highest level of the EU agreement of low voltage motors.

These efficiency levels apply to 2- and 4-pole, three phase squirrel cage induction motors rated for 400 V, 50 Hz with S1 duty class

with the output 1.1 to 90 kW, which account for the largest volume on the market.

The efficiency of motors from different manufacturers are collated in a database, EURODEEM, published by the European Commission. It is accessible over the Internet at <http://iamest.jrc.it/projects/eem/eurodeem.htm>.

EU efficiency classes for 2-pole motors

Output kW	2-pole Boarderline	
	EFF2/EFF3	EFF1/EFF2
1.1	76.2	82.8
1.5	78.5	84.1
2.2	81.0	85.6
3	82.6	86.7
4	84.2	87.6
5.5	85.7	88.6
7.5	87.0	89.5
11	88.4	90.5
15	89.4	91.3
18.5	90.0	91.8
22	90.5	92.2
30	91.4	92.9
37	92.0	93.3
45	92.5	93.7
55	93.0	94.0
75	93.6	94.6
90	93.9	95.0

EU efficiency classes for 4-pole motors

Output kW	4-pole Boarderline	
	EFF2/EFF3	EFF1/EFF2
1.1	76.2	83.8
1.5	78.5	85.0
2.2	81.0	86.4
3	82.6	87.4
4	84.2	88.3
5.5	85.7	89.2
7.5	87.0	90.1
11	88.4	91.0
15	89.4	91.8
18.5	90.0	92.2
22	90.5	92.6
30	91.4	93.2
37	92.0	93.6
45	92.5	93.9
55	93.0	94.2
75	93.6	94.7
90	93.9	95.0

ABB three phase induction motors, 400 V 50 Hz - EU motor efficiency levels

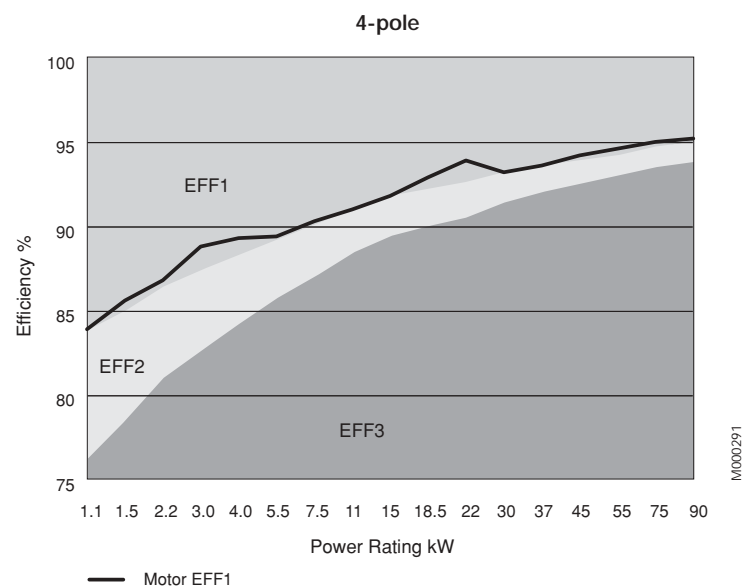
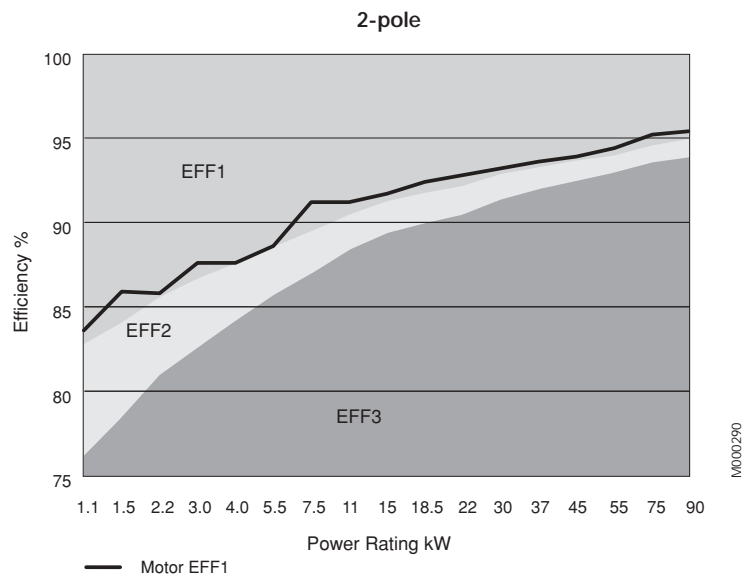

General technical specification

Mechanical and electrical design

Mounting arrangements

1

	Code I/Code II						Product code pos. 12
Foot-mounted motor.	IM B3 IM 1001	IM V5 IM 1011	IM V6 IM 1031	IM B6 IM 1051	IM B7 IM 1061	IM B8 IM 1071	A = foot-mounted, term.box top R = foot-mounted, term.box RHS L = foot-mounted, term.box LHS
							M000007
Flange-mounted motor, large flange	IM B5 IM 3001	IM V1 IM 3011	IM V3 IM 3031	*) IM 3051	*) IM 3061	*) IM 3071	B = flange mounted, large flange
							M000008
Flange-mounted motor, small flange	IM B14 IM 3601	IM V18 IM 3611	IM V19 IM 3631	*) IM 3651	*) IM 3661	*) IM 3671	C = flange mounted, small flange
							M000009
Foot- and flange-mounted motor with feet, large flange	IM B35 IM 2001	IM V15 IM 2011	IM V36 IM 2031	*) IM 2051	*) IM 2061	*) IM 2071	H = foot/flange-mounted, term.box top S = foot/flange-mounted, term.box RHS T = foot/flange-mounted, term.box LHS
							M000010
Foot- and flange-mounted motor with feet, small flange	IM B34 IM 2101	IM V17 IM 2111	IM 2131	IM 2151	IM 2161	IM 2171	J = foot/flange-mounted, small flange
							M000011
Foot-mounted motor, shaft with free extensions	IM 1002	IM 1012	IM 1032	IM 1052	IM 1062	IM 1072	
							M000012

*) Not stated in IEC 60034-7.

Cooling

Designation system concerning methods of cooling refers to standard IEC 60034-6.

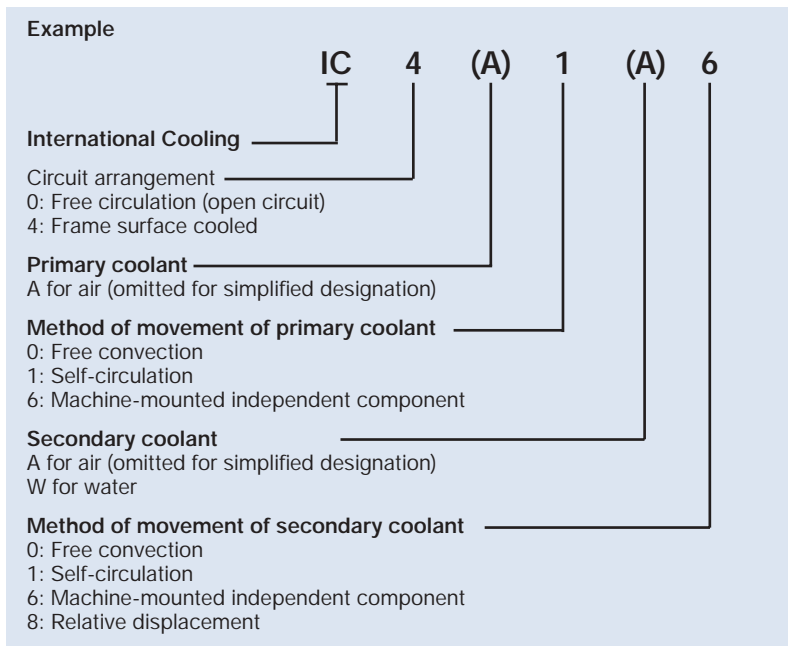

Degrees of protection: IP code/IK code

Classification of degrees of protection provided by enclosures of rotating machines are refers to:

- Standard IEC 60034-5 or EN 60529 for IP code
- Standard EN 50102 for IK code

IP protection:

Protection of persons against getting in contact with (or approaching) live parts and against contact with moving parts inside the enclosure. Also protection of the machine against ingress of solid foreign objects. Protection of machines against the harmful effects due to the ingress of water

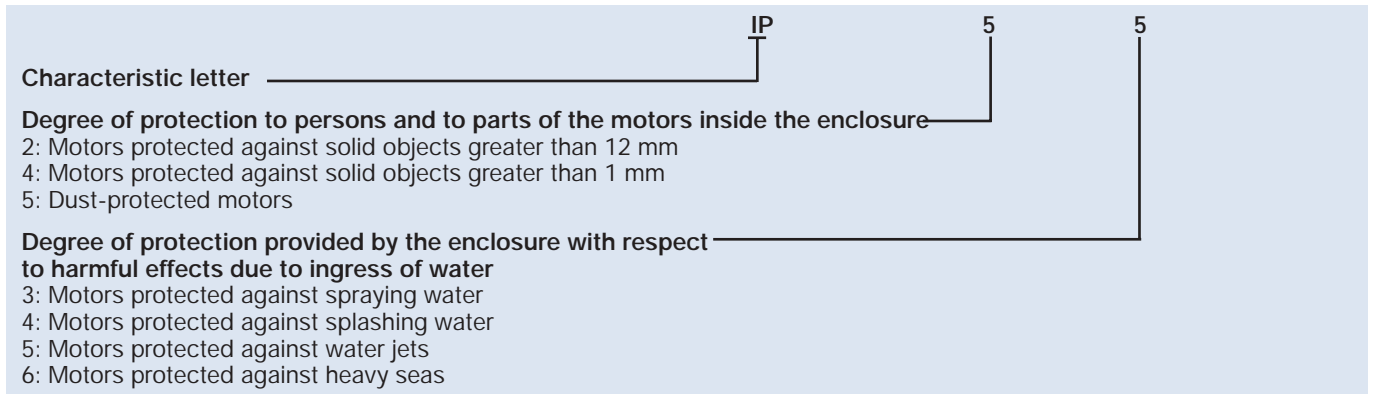

IK code:

Classification of degrees of protection provided by enclosure for motors against external mechanical impacts.

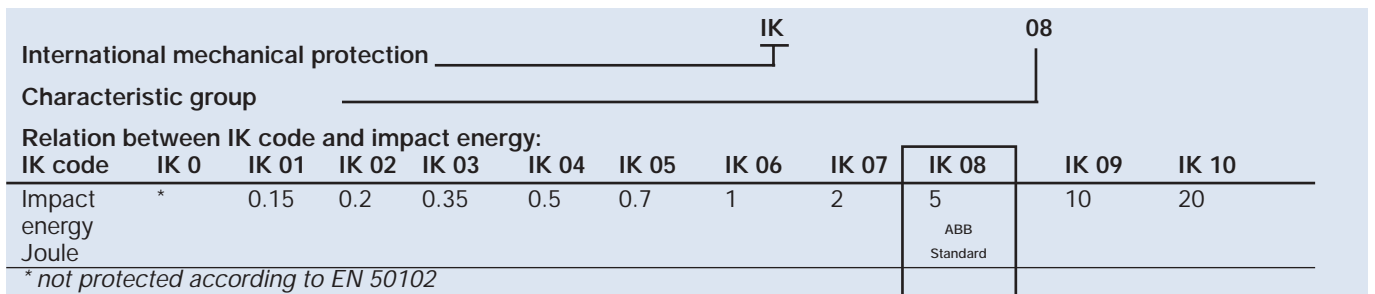

Insulation

ABB uses class F insulation systems, which, with temperature rise B, is the most common requirement among industry today.

The use of Class F insulation with Class B temperature rise gives ABB products a 25° C safety margin. This can be used to increase the loading for limited periods, to operate at higher ambient temperatures or altitudes, or with greater voltage and frequency tolerances. It can also be used to extend insulation life. For instance, a 10 K temperature reduction will extend the insulation life.

Class F insulation system

- Max ambient temperature 40° C
- Max permissible temperature rise 105 K
- Hotspot temperature margin + 10 K

Class B rise

- Max ambient temperature 40° C
- Max permissible temperature rise 80 K
- Hotspot temperature margin + 10 K

Insulation system temperature class

- Class F 155° C
- Class B 130° C
- Class H 180° C

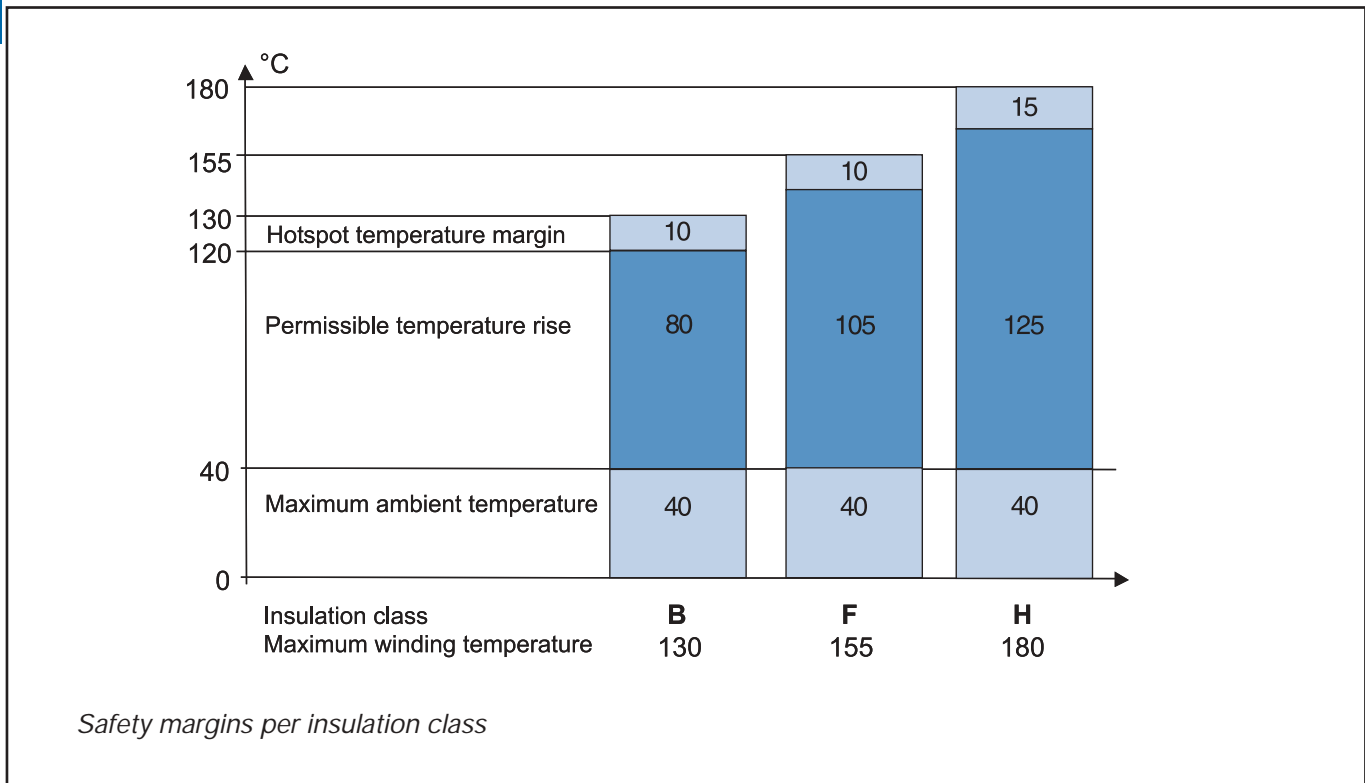

All ABB high voltage motors are made with form wound windings with Micadur® Compact Industry Insulation System (class F). For more information, please see the brochure Micadur® -Compact Industry, Insulation System for Rotating Electrical Machines (code 3BFP 001 980 R0101 REV B 06/2003).

Frequency converter drives for low voltage motors

Squirrel cage induction motors offer excellent availability, reliability and efficiency. With a frequency converter – a variable speed drive (VSD) – the motor will deliver even better value. A variable speed drive motor can be started softly with low starting current, and the speed can be controlled and adjusted to suit the application demand without steps over a wide range. Also the use of a frequency converter together with a squirrel cage motor usually leads to remarkable energy and environmental savings.

Process performance motors manufactured by ABB are designed for both, variable speed and direct on line use. Also a wide range of options is available to fit the motors even to the most demanding applications.

When selecting process performance motors to variable speed drives, following points shall be taken into consideration:

1. Dimensioning

The voltage (or current) fed by the frequency converter is not purely sinusoidal. This may increase the losses, vibration, and noise of the motor. Furthermore, a change in the distribution of the losses may affect to the temperature rises of the motor. In each case, the motor must be correctly sized according to the instructions supplied with the selected frequency converter.

When using ABB converters, please use ABB's DriveSize dimensioning programme or the loadability curves of the corresponding converter type for sizing the motors. The loadability curve of a process performance motor used with ABB's ACS 800 -frequency converters can be found in figure 3.

2. Speed range

In a frequency converter drive, the actual operating speed of the motor may deviate considerably from its nominal speed (i.e. the speed stamped on the rating plate).

For higher speeds, ensure that the highest permissible rotational speed of the motor or the critical speed of the entire equipment is not exceeded. When high speed operation exceeds the nominal speed of the motor, the following points should be checked:

- Maximum torque of the motor
- Bearing construction
- Lubrication
- Balancing
- Critical speeds
- Shaft seals
- Ventilation
- Fan noise

Guideline values of maximum speeds for process performance motors are described in figures 1a and 1b.

Figure 1a. Guideline values of maximum speeds for process performance cast iron motors

Frame size	Speed r/min	
	2-pole	4-pole
71 – 200	4000	3600
225 – 280	3600	2600
315	3600	2300
355 SM, ML	3600	2000
355 LK	3000	2000
400	3600	1800
450	3600	1800

Figure 1b. Guideline values of maximum speeds for process performance aluminum motors

Frame size	Speed r/min	
	2-pole	4-pole
112 – 200	4500	4500
225 – 280	3600	3600

At low speed operation the cooling capacity of the fan decreases, which may cause higher temperature rises in the motor. A separate constant speed fan can be used to increase cooling capacity and loadability at low speed. It is also important to check the performance of the lubrication at low speeds.

3. Lubrication

The effectiveness of the motor lubrication should be checked by measuring the bearing temperature under normal operating conditions. If the measured temperature is higher than +80°C, the relubrication intervals specified in ABB's Low Voltage Motors Manual must be shortened; i.e. the relubrication interval should be halved for every 15 K increase in bearing temperature. If this is not possible ABB recommends the use of lubricants suitable for high operating temperature conditions. These lubricants allow a normal relubrication interval and a 15 K increase in bearing temperature conditions.

At continuous operation on very low speeds as well as at very low temperatures the lubrication capabilities of standard greases may not be sufficient and special greases with additives are needed. For more information, please contact ABB.

If the motors are equipped with sealed bearings i.e. bearings greased for life, it must be noted that when the operating temperature differs from the designed, also the lifetime of the bearing will differ from the original. More information about the lifetime of the bearings can be found from the product specific sections of this manual.

The use of so called conductive greases for elimination of bearing currents is not recommended due to their poor lubrication characteristics and low conductivity.

4. Insulation protection

Most of the low voltage frequency converters have IGBT power components with very rapid switching, steep voltage pulses and reflections at the cables. Those increase voltage stresses at the winding of the motor and therefore, the precautions described in figure 2 below must be taken to avoid risks of insulation damage. Mentioned measures apply to Process Performance Motors with ACS 550 and ACS 800 drives with uncontrolled DC-voltage. For other alternatives and converter types, please contact ABB.

5. Bearing currents

Bearing voltages and currents must be avoided in all motors. Assuming the use of ABB ACS 550 or ACS 800 drives, with uncontrolled DC-voltage, insulated bearings and/or properly dimensioned filters at the converter output must be used according to the instructions in figure 2 below. (For other alternatives and converter types, please contact ABB.) When ordering, clearly state which alternative will be used.

For more information about bearing currents and voltages, please contact ABB.

6. Cabling, grounding and EMC

The use of a frequency converter sets higher demands on the cabling and grounding of the drive system. The motor must be cabled by using shielded symmetrical cables and cable glands providing 360° bonding (also called EMC-glands). For motors up to 30 kW unsymmetrical cables can be used, but shielded cables are always recommended, especially if there are sensitive sensors in the driven application.

For motors in frame size IEC 280 and upward, additional potential equalisation between the motor frame and the machinery is needed, unless they are installed on a common steel fundament. When a steel fundament is used for the potential equalisation, the high frequency conductivity of this connection should be checked.

More information about grounding and cabling of a variable speed drive can be found from the manual "Grounding and cabling of the drive system" (Code: 3AFY 61201998 R0125 REV B)

For fulfilling the EMC requirements, special EMC cable(s) must be used in addition to the correct cable gland mounting, with special, extra earthing pieces. Please refer to the manuals of the frequency converter.

Figure 2. Selection rules for insulation and filtering in variable speed drives

	Motor nominal power P_N or frame size		
	$P_N < 100$ kW	$P_N \geq 100$ kW or IEC 315 \leq Frame size \leq IEC 355	$P_N \geq 350$ kW or IEC 400 \leq Frame size \leq IEC 450
$U_N \leq 500$ V	Standard motor	Standard motor + Insulated N-bearing	Standard motor + Insulated N-bearing + Common mode filter
$U_N \leq 600$ V	Standard motor + dU/dt-filter (reactor) OR Reinforced insulation	Standard motor + dU/dt-filter (reactor) + Insulated N-bearing OR Reinforced insulation + Insulated N-bearing	Standard motor + Insulated N-bearing + dU/dt-filter (reactor) + Common mode filter OR Reinforced insulation + Insulated N-bearing + Common mode filter
$U_N \leq 690$ V	Reinforced insulation + dU/dt-filter (reactor)	Reinforced insulation + dU/dt-filter (reactor) + Insulated N-bearing	Reinforced insulation + Insulated N-bearing + dU/dt-filter (reactor) + Common mode filter

dU/dt-filter (reactor)

Series reactor. DU/dt -filter decreases the changing rate of the phase and main voltages and thus reduces voltage stresses in the windings. DU/dt -filters also decrease so-called common mode currents and the risk of bearing currents.

Common mode filters

Common mode filters reduce so-called common mode currents in VSD applications and thus decrease the risk of bearing currents.

Common mode filters do not significantly affect the phase or main voltages on the motor terminals.

Insulated Bearings

Bearings with insulated inner or outer races are used as the standard solution. So-called hybrid bearings, i.e. bearings with non-conductive ceramic rolling elements, can also be used in special applications. More information for spare part selection is available on request.

Validity

Measures mentioned in Figure 2 apply to Process performance motors with ACS 550 and ACS 800 drives with uncontrolled DC-voltage. For other alternatives and converter types, please contact ABB.

Motor loadability with 800 -frequency converter

The loadability curve in figure 3 below is a guideline curve for standard ACS 800 drives with DTC-control. For exact values please contact ABB. It is possible to use the loadability curve also for other frequency converters, but it shall be noted that the harmonic content and control algorithms varies between different frequency converters and thus the temperature rise of the motor also differs.

These guidelines present the maximum continuous load torque of a motor as a function of frequency (speed) to give the same temperature rise as with rated sinusoidal supply at nominal frequency and full rated load.

The temperature rise of squirrel cage motors manufactured by ABB is normally class B. However, if the ABB catalogue indicates that class F temperature rise is utilised on a sinusoidal supply, the dimensioning of the motor at frequency converter supply shall be done according to the temperature rise class B loadability curve.

If the motor is utilised according to the loadability curve temperature rise class F, the temperature rise in other parts of the motor should be noted and the lubrication intervals and type of grease checked.

For further information, please contact ABB.

1

Figure 3. Motor loadability with ACS 800, Field weakening point 50 Hz.

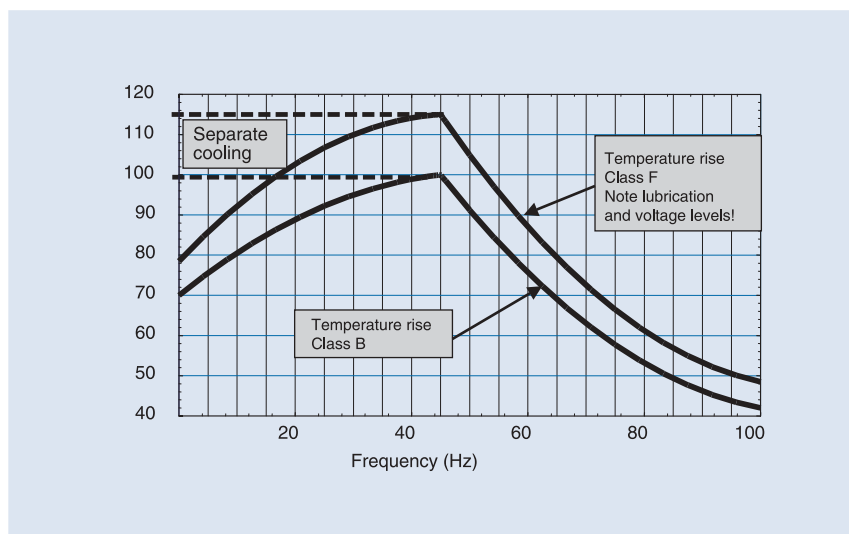

Frequency converter drives for high voltage motors

High voltage, M3BM, motors are suitable for ABB ACS 1000 series' converters or equivalent with sinusoidal output, quadratic load torque (pump, fan).

For more information, please contact your local ABB Sales office



Low Voltage Process Performance Cast Iron Motors

Totally enclosed squirrel cage three phase
low voltage motors,
Sizes 71 - 450, 0.25 to 1000 kW



2

www.abb.com/motors&drives

- > Motors
- >> Low Voltage Motors
- >>> Process Performance Motors

Mechanical design	14
Rating plates	24
Ordering information.....	25
Technical data.....	26
Variant codes	40
Dimension drawings.....	46
Accessories	59
Construction	66
Cast iron motors in brief.....	67

Mechanical design

Stator

The motor frames including feet, bearing housing and terminal box are made of cast iron. Integrally cast feet allow a very rigid mounting and minimal vibration.

Motors can be supplied for foot mounting, flange mounting and combinations of these.

Drain holes

Motors that will be operated in very humid or wet environments, and especially under intermittent duty, should be provided with drain holes. The appropriate IM designation, such as IM 3031, is specified, on the basis of the method of motor mounting.

In the basic design, sizes 71 to 132 are supplied without drain holes, although these can be provided as an option.

Motor sizes 160 to 450 are fitted with drain holes and closable plugs. The plugs are open on delivery. When mounting the motors, ensure that the drain holes face downwards.

In the case of vertical mounting, the upper plug must be hammered home completely. In very dusty environments, both plugs should be hammered home.

When mounting arrangement differs from foot mounted IM B3, please mention variant code 066 when ordering.

See variant codes 065 and 066 under the heading "Drain holes".

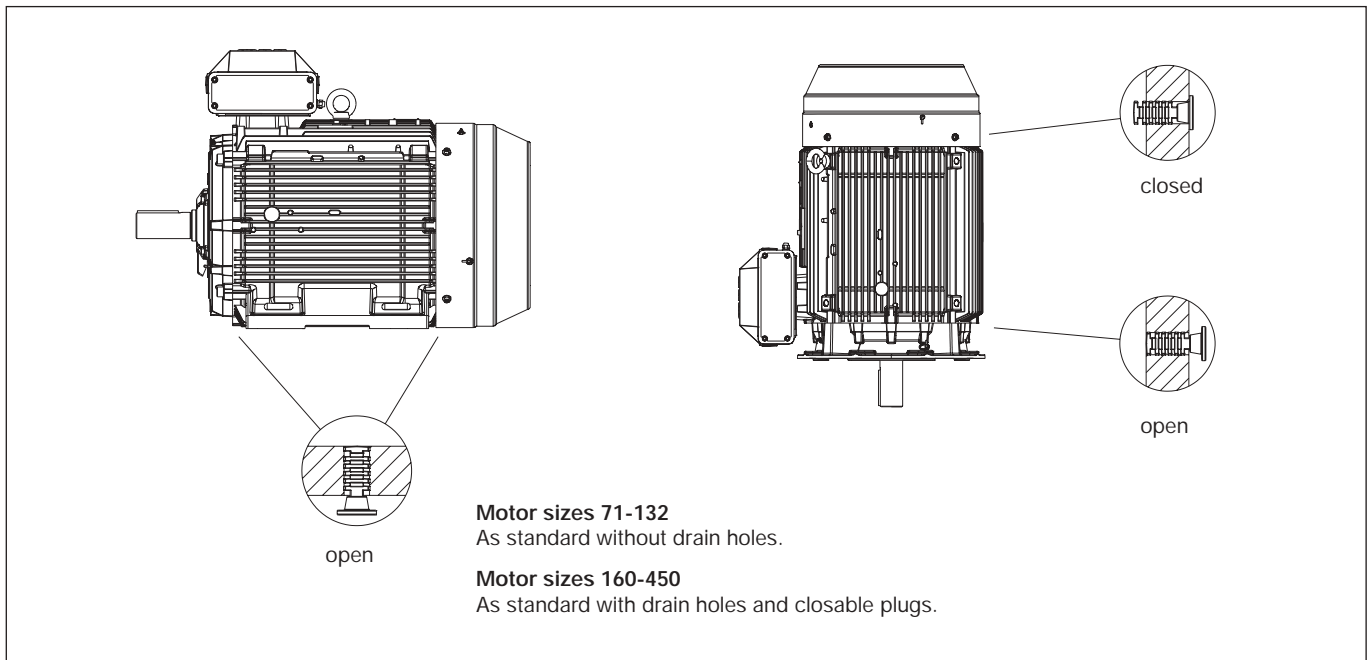

M000178

Terminal box

Terminal boxes are mounted on the top of the motor as standard. The terminal box can also be mounted on the left or right side, see ordering information.

The terminal boxes of motor sizes 71 to 400 can be turned 4x90° except in motor size 450 rotated 2x180°, to allow cable entry from either side of the motor.

Degree of protection of standard terminal box is IP 55.

Motor sizes 71 to 132 come with cable entries tapped in the terminal box frame, and can be provided with cable glands as an option.

Motor sizes 160 to 250 come with connection flanges with tapped cable entries, and can be provided with cable glands as an option.

In **motor sizes 280 to 450** the terminal box is normally equipped with cable glands or cable boxes, see following pages.

If no ordering information on the cable is given, it is assumed to be p.v.c. -insulated and termination parts are supplied according to the table on the following pages.

To enable the supply of suitable terminations for the motor, please state cable type, quantity and size when ordering. Non-standard design of terminal boxes; e.g. size, degree of protection, are available as options.

Terminations are suitable for Cu- and Al-cables (Al-cables on request for motor sizes 71 to 250). Cables are connected to the terminals by cable lugs which are not included with the motor.

Please see variant code pages for options dimension drawings for terminal boxes can also be found after the motor drawings.



Terminal box for motor sizes 71 to 132



Terminal box for motor sizes 160 to 250

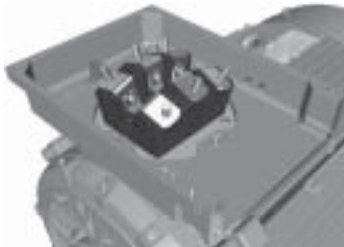

Terminal box for motor sizes 280 to 315, provided either with a cable gland or a cable box.

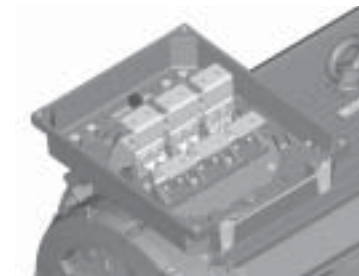

Terminal box for motor sizes 355 to 450, provided either with a cable gland or a cable box.

Co-ordination of terminal boxes and cable entries

If no ordering information on the cable is given, it is assumed to be p.v.c. -insulated and termination parts are supplied according to the following tables. These are supplied when using variant code '230 Standard cable glands' when ordering.

In **motor sizes 280 to 450** the terminal box is normally equipped with cable glands or cable boxes according to the tables on the following pages. The table on next page shows the different alternatives available for cable boxes and cable entries. Other types on request.

Voltage 220 - 690 V, 50 Hz

Motor size	Terminal box	Flange opening	Main metric cable entry	Auxiliary cable	Cable gland entries diameter mm	Max. connection cable area, mm ²	Max. rated current A (D/Y conn.)	Terminal bolt size
71	-		2 x M16		Ø5-10	1 x 6		M4
80-90	-		2 x M25		Ø8-13	1 x 6		M4
100-132	-		2 x M32		Ø15-20	1 x 16		M5
160 -180	-		2 x M40	1 x M16 x 1.5	Ø19-27	1 x 35	63	M6
200 -250	-		2 x M63	1 x M16 x 1.5	Ø34-45	1 x 70	160	M10

Motor sizes 280 to 450 – Co-ordination of terminal boxes and cable entries

Motor size	Voltage/freq. code	Terminal box	Top-mounted Flange or adapter	Side-mounted Flange or adapter	Cable box or cable gland	Gland thread	Cable diameter	Max. connection cable area mm ²
3000 r/min (2 poles)								
280		210	3GZF294730-749	3GZF294730-749	2x 3GZF294730-613	2x M63x1.5	2x Ø32-49	2x150
315SM, ML		370	3GZF294730-753	3GZF294730-753	2x 3GZF294730-613	2x M63x1.5	2x Ø32-49	2x240
315LKA, LKB		370	3GZF294730-753	3GZF294730-753	2x 3GZF294730-613	2x M63x1.5	2x Ø32-49	2x240
315LKC		750	3GZF294730-944	3GZF294730-759	3GZF294730-301		2x Ø48-60	4x240
355 SMA	D	750	3GZF294730-944	3GZF294730-759	3GZF294730-301		2x Ø48-60	4x240
355 SMA	E	370	3GZF294730-753	3GZF294730-753	2x 3GZF294730-613	2x M63x1.5	2x Ø32-49	2x240
355 SMB, SMC		750	3GZF294730-944	3GZF294730-759	3GZF294730-301		2x Ø48-60	4x240
355 ML, LK		750	3GZF294730-944	3GZF294730-759	3GZF294730-501		2x Ø60-80	4x240
400 L, LK		750	3GZF294730-944	3GZF294730-759	3GZF294730-501		2x Ø60-80	4x240
450 LA	D	1200	see option ¹⁾	-	see option ¹⁾		see option ¹⁾	6x240
	E	750	3GZF294730-944	-	3GZF294730-501		2x Ø60-80	4x240
450 LB	D, E	1200	see option ¹⁾	-	see option ¹⁾		see option ¹⁾	6x240
450 LC	E, U	1200	see option ¹⁾	-	see option ¹⁾		see option ¹⁾	6x240
1500 r/min (4 poles)								
280		210	3GZF294730-749	3GZF294730-749	2x 3GZF294730-613	2x M63x1.5	2x Ø32-49	2x150
315SM, ML		370	3GZF294730-753	3GZF294730-753	2x 3GZF294730-613	2x M63x1.5	2x Ø32-49	2x240
315LKA, LKB		370	3GZF294730-753	3GZF294730-753	2x 3GZF294730-613	2x M63x1.5	2x Ø32-49	2x240
315LKC		750	3GZF294730-944	3GZF294730-759	3GZF294730-301		2x Ø48-60	4x240
355 SMA	D	750	3GZF294730-944	3GZF294730-759	3GZF294730-301		2x Ø48-60	4x240
355 SMA	E	370	3GZF294730-753	3GZF294730-753	2x 3GZF294730-613	2x M63x1.5	2x Ø32-49	2x240
355 SMB, SMC		750	3GZF294730-944	3GZF294730-759	3GZF294730-301		2x Ø48-60	4x240
355 ML, LK		750	3GZF294730-944	3GZF294730-759	3GZF294730-501		2x Ø60-80	4x240
400 L, LK		750	3GZF294730-944	3GZF294730-759	3GZF294730-501		2x Ø60-80	4x240
450 LA	D	1200	see option ¹⁾	-	see option ¹⁾		see option ¹⁾	6x240
	E	750	3GZF294730-944	-	3GZF294730-501		2x Ø60-80	4x240
450 LB	D, E	1200	see option ¹⁾	-	see option ¹⁾		see option ¹⁾	6x240
450 LC	D, E	1200	see option ¹⁾	-	see option ¹⁾		see option ¹⁾	6x240
1000 r/min (6 poles)								
280		210	3GZF294730-749	3GZF294730-749	2x 3GZF294730-613	2x M63x1.5	2x Ø32-49	2x150
315		370	3GZF294730-753	3GZF294730-753	2x 3GZF294730-613	2x M63x1.5	2x Ø32-49	2x240
355 SMA, SMB		370	3GZF294730-753	3GZF294730-753	2x 3GZF294730-613	2x M63x1.5	2x Ø32-49	2x240
355 SMC	D	750	3GZF294730-944	3GZF294730-759	3GZF294730-301		2x Ø48-60	4x240
355 SMC	E	370	3GZF294730-753	3GZF294730-753	2x 3GZF294730-613	2x M63x1.5	2x Ø32-49	2x240
355 ML		750	3GZF294730-944	3GZF294730-759	3GZF294730-301		2x Ø48-60	4x240
355 LKA		750	3GZF294730-944	3GZF294730-759	3GZF294730-301		2x Ø48-60	4x240
355 LKB		750	3GZF294730-944	3GZF294730-759	3GZF294730-501		2x Ø60-80	4x240
400 L, LK		750	3GZF294730-944	3GZF294730-759	3GZF294730-501		2x Ø60-80	4x240
450 LA	D, E	750	3GZF294730-944	-	3GZF294730-501		2x Ø60-80	4x240
450 LB	D	1200	see option ¹⁾	-	see option ¹⁾		see option ¹⁾	6x240
	E	750	3GZF294730-944	-	3GZF294730-501		2x Ø60-80	4x240
450 LC	D	1200	see option ¹⁾	-	see option ¹⁾		see option ¹⁾	6x240
	E	750	3GZF294730-944	-	3GZF294730-501		2x Ø60-80	4x240
750 r/min (8 poles)								
280		210	3GZF294730-749	3GZF294730-749	2x 3GZF294730-613	2x M63x1.5	2x Ø32-49	2x150
315		370	3GZF294730-753	3GZF294730-753	2x 3GZF294730-613	2x M63x1.5	2x Ø32-49	2x240
355 SM		370	3GZF294730-753	3GZF294730-753	2x 3GZF294730-613	2x M63x1.5	2x Ø32-49	2x240
355 ML	D	750	3GZF294730-944	3GZF294730-759	3GZF294730-301		2x Ø48-60	4x240
355 ML	E	370	3GZF294730-753	3GZF294730-753	2x 3GZF294730-613	2x M63x1.5	2x Ø32-49	2x240
355 LK		750	3GZF294730-944	3GZF294730-759	3GZF294730-301		2x Ø48-60	4x240
400 LA, LB, LKA, LKB		750	3GZF294730-944	3GZF294730-759	3GZF294730-301		2x Ø48-60	4x240
400 LC, LKC		750	3GZF294730-944	3GZF294730-759	3GZF294730-501		2x Ø60-80	4x240
450 L ₋	D, E	750	3GZF294730-944	-	3GZF294730-501		2x Ø60-80	4x240

Voltage/frequency codes:

D = 380-420 VD 50 Hz, 660/690 VY 50 Hz, 440-480 VD 60 Hz
E = 500 VD 50 Hz, 575 VD 60 Hz

Terminal bolt sizes M12.

Earthing bolt size on stator frame M10.

¹⁾ Options - Variant code 444:

Terminal box	Adapter	Cable box or flange	Cable diameter
1200	3GZF294730-944	3GZF294730-301	2x Ø48-60
	3GZF294730-944	3GZF294730-501	2x Ø60-80
	3GZF294730-945	2x 3GZF294730-301	4x Ø48-60
	3GZF294730-945	2x 3GZF294730-501	4x Ø60-80
	3GZF293745-1	3x 3GZF294730-301	6x Ø48-60
	3GZF293745-1	3x 3GZF294730-501	6x Ø60-80
	3GZF293745-2	Flange for gable glands	

Terminal box	Cable cross-section	Max. rated current		Earthing
		D-connection	Y-connection	
210	25 mm ²	260	150	2xM10
210	35 mm ²	363	210	2xM10
370	50 mm ²	470	270	2xM10
370	70 mm ²	640	370	2xM10
750	2 x 70 mm ²	950	550	2xM10
750	2 x 95 mm ²	1300	750	2xM10
1200	2 x 120 mm ²	1650	950	4xM12
1200	2 x 150 mm ²	2100	1200	4xM12

Adapter and cable box for terminal box size 1200.

To be defined when ordering

Cable cross-section area between the winding and the terminal board.

M3BP 280 - 315

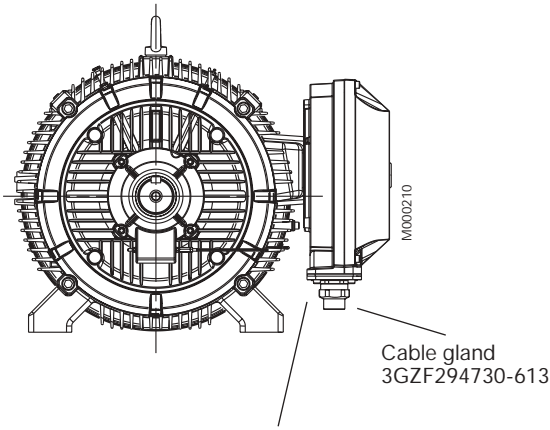

M3BP 355 - 400

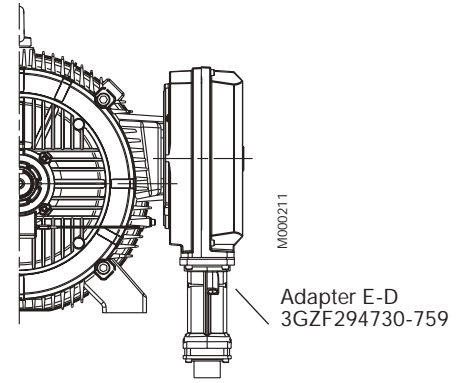

Adapter D-D (optional)
3GZF294730-943

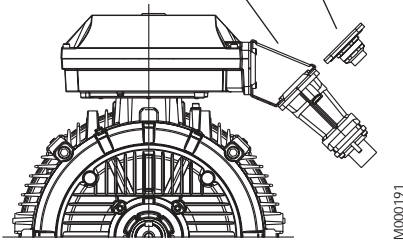

M3BP 355 - 450

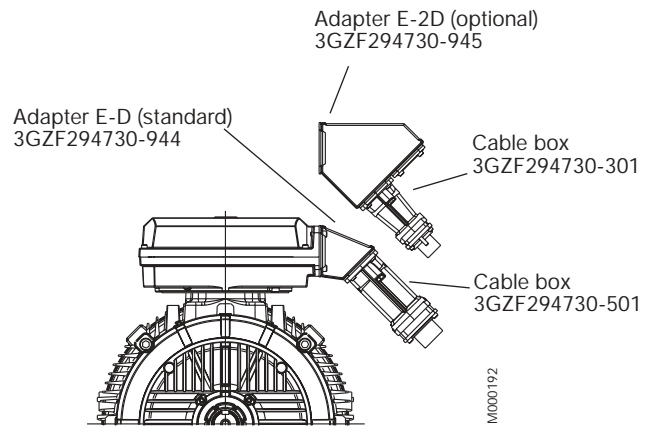

Auxiliary devices (view from N-end)

Cable glands for auxiliary devices
as standard 2 x M20 x 1.5.

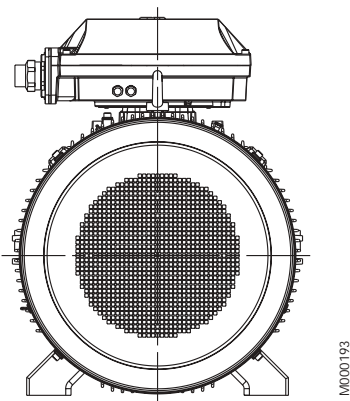

M3BP 450 with terminal box 1200

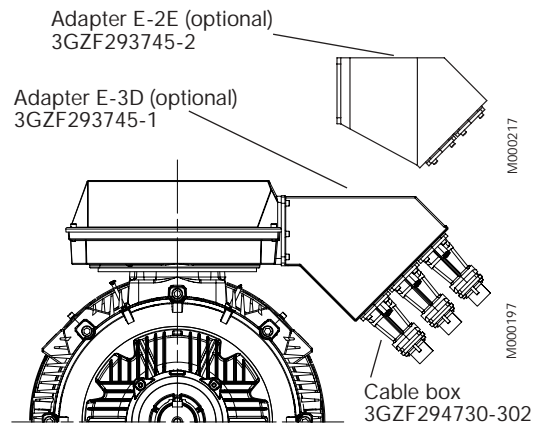

Dimensions for terminal box inlets

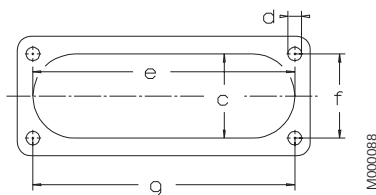

Inlet	c	e	f	g	d
C	62	193	62	193	M8
D	100	300	80	292	M10
E	115	370	100	360	M12

Bearings

The motors are normally fitted with single-row deep groove ball bearings as listed in the table below.

If the bearing at the D-end is replaced with a roller bearing (NU- or NJ-), higher radial forces can be handled. Roller bearings are suitable for belt drive applications.

Basic version with deep groove ball bearings

Motor size	Number of poles	Deep groove ball bearings	
		D-end	N-end
71	2-6	6202 2RS C3	6202 2RS C3
80	2-6	6204 2RS C3	6204 2RS C3
90	2-6	6205 2RS C3	6205 2RS C3
100	2-6	6206 2RS C3	6206 2RS C3
112	2-6	6207 2RS C3	6206 2RS C3
132	2-6	6208 2RS C3	6207 2RS C3
160	2-12	6309/C3	6309/C3
180	2-12	6310/C3	6309/C3
200	2-12	6312/C3	6310/C3
225	2-12	6313/C3	6312/C3
250	2-12	6315/C3	6313/C3
280	2	6316/C3	6316/C3
	4-12	6316/C3	6316/C3
315	2	6316/C3	6316/C3
	4-12	6319/C3	6316/C3
355	2	6316M/C3	6316M/C3
	4-12	6322/C3	6316/C3
400	2	6317M/C3	6317M/C3
	4-12	6324/C3	6319/C3
450	2	6317M/C3	6317M/C3
	4-12	6326M/C3	6322/C3

¹⁾ On request

When there are high axial forces, angular-contact ball bearings should be used. This option is available on request. When a motor with angular-contact ball bearings is ordered, the method of mounting and direction and magnitude of the axial force must be specified. For special bearings, please see the variant codes.

Version with roller bearings, variant code 037

Motor size	Number of poles	Roller bearings, variant code 037	
		D-end	
71	2-6	-	
80	2-6	-	
90	2-6	-	
100	2-6	-	
112	2-6	-	
132	2-6	-	
160	2-12	NU 309	
180	2-12	NU 310	
200	2-12	NU 312	
225	2-12	NU 313	
250	2-12	NU 315	
280	2	¹⁾	
	4-12	NU 316/C3	
315	2	¹⁾	
	4-12	NU 319/C3	
355	2	¹⁾	
	4-12	NU 322/C3	
400	2	¹⁾	
	4-12	NU 324/C3	
450	2	¹⁾	
	4-12	NU 326/C3	

Axially-locked bearings

The outer bearing ring at the D-end can be axially locked with an inner bearing cover. The inner ring is locked by tight tolerance to the shaft.

All motors are equipped as standard with an axially-locked bearing at the D-end.

Transport locking

Motors that have roller bearings or an angular contact ball bearing are fitted with a transport lock before despatch to prevent damage to the bearings during transport. In case of transport locked bearing, motor sizes 280 to 450 are provided with a warning sign.

Locking may also be fitted in other cases where transport conditions are suspected of being potentially damaging.

Bearing seals

Motor sizes 71 to 132 are equipped with sealed bearings (2RS). The size and type of seals for sizes

160 to 450 are in accordance with the table below:

Motor size	Number of poles	Standard design		Alternative design
		Axial seal		Radial seal (DIN 3760)
		D-end	N-end	Variant code 072
160	2-12	RB45	V-45A	45x62x8
180	2-12	RB50	RB45	50x68x8
200	2-12	RB60	V-50A	60x80x8
225	2-12	RB65	V-60A	65x85x10
250	2-12	RB75	V-65A	75x95x10

Axial seal:
RB45...75 = Gamma-ring
V50...95 = V-ring

Motor size	Number of poles	Standard design		Alternative design	
		D-end	N-end	D-end	N-end
280	2	Labyrinth seal	Axial seal VS80	-	Labyrinth seal
280	4-12	Axial seal VS80	Axial seal VS80	Labyrinth seal Radial seal 80x110x10	Labyrinth seal Radial seal 80x110x10
315	2	Labyrinth seal	Axial seal VS80	-	Labyrinth seal
315SM, ML	4-12	Axial seal VS95	Axial seal VS80	Labyrinth seal Radial seal 95x125x10	Labyrinth seal Radial seal 80x110x10
315LK	4-12	Labyrinth seal	Axial seal VS80	-	Labyrinth seal Radial seal 80x110x10
355	2	Labyrinth seal	Axial seal VS80	-	Labyrinth seal
355	4-12	Labyrinth seal	Axial seal VS80	-	Labyrinth seal
400	2	Labyrinth seal	Labyrinth seal	-	-
400	4-12	Labyrinth seal	Axial seal VS95	-	Labyrinth seal
450	2	Labyrinth seal	Labyrinth seal	-	-
450	4-12	Labyrinth seal	Labyrinth seal	-	-

Motor sizes 71-132

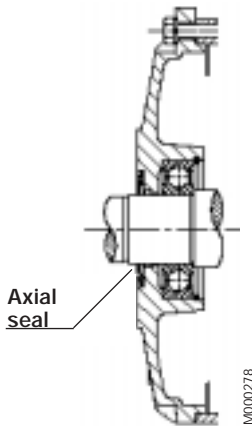

Motor sizes 160-250

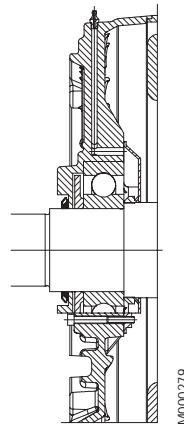

Motor sizes 280-450

Labyrinth seal

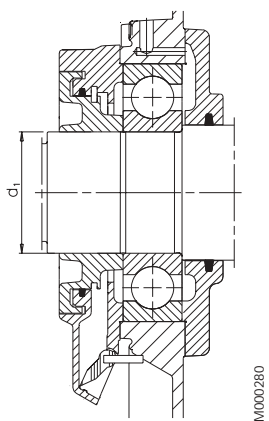

V-ring

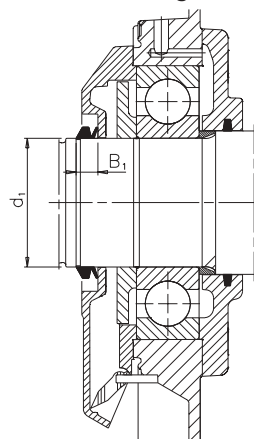

Radial seal

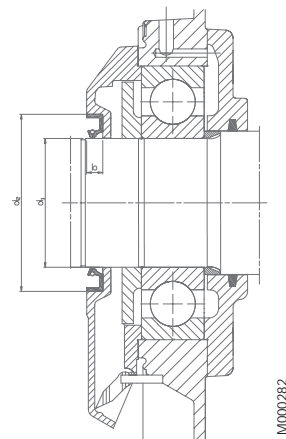

Bearing life

The nominal life L_{10h} of a bearing is defined according to ISO 281 as the number of operating hours achieved or exceeded by 90% of identical bearings in a large test series under certain specified conditions. 50% of the bearings achieve at least five times this figure.

The calculated bearing life L_{10h} for power transmission by means of a coupling (horizontal machine):

Motor sizes 280 to 450 \geq 200,000 hours.

Lubrication

On delivery, the motors are ready lubricated with high quality grease. The recommended grease used can be seen from ABB's Low Voltage Motors Manual delivered together with the motor or for frame sizes 160-450 from the lubrication plate fastened to the motor frame. See example of a lubrication plate on page 24.

Lubrication method in cast iron motors

M2BA 71-132 Permanent greased bearings as standard

M3BP 160-450 Regreasable bearings as standard solution

M3BP 160-250 Permanent greased bearings as an option

Motors with permanently greased bearings

Standard versions of frame sizes 71-132 are equipped with closed bearings, type 2RS1. Also motors with frame sizes 160-250 can be equipped with permanently greased bearings. Bearings are lubricated with high quality, high temperature grease. Bearing types are mentioned in the rating plates.

The following values can be used as a guide for bearing lifetime, depending on application and load conditions:

4-8 pole motors about 40,000 h

2 pole motors about 20,000 h

Motors with relubrication nipples

For sizes 280 to 450 the bearing system has been built so that a valve disc can be used to ease the lubrication. Motors are lubricated while running.

Grease outlet opening has closing valves at both ends. This should be opened before greasing and closed 1-2 hours after regreasing. After lubrication close the valves. This ensures that the construction is tight and dust or dirt cannot get inside the bearing.

As an option, a grease collection method can be used.

Lubrication intervals

ABB follows the L1-principle in defining lubrication interval. That means that 99% of the motors are sure to make the interval time. The lubrication intervals can also be calculated according to the L10-principle, which are normally doubled compared to L1-values. Values available from ABB at request.

The table below gives lubrication intervals according to the L1-principle for different speeds. The values are valid for horizontal mounted motors (B3), with about 80°C bearing temperature and using high quality grease with lithium complex soap and mineral or PAO-oil.

For more information, see ABB's Low Voltage Motors Manual.

Frame size	Amount of grease g	3600 r/min	3000 r/min	1800 r/min	1500 r/min	1000 r/min	500-750 r/min
------------	--------------------	------------	------------	------------	------------	------------	---------------

Frame size	Amount of grease g	3600 r/min	3000 r/min	1800 r/min	1500 r/min	1000 r/min	500-750 r/min
------------	--------------------	------------	------------	------------	------------	------------	---------------

Ball bearings: lubrication intervals in duty hours

112	10	10000	13000	18000	21000	25000	28000
132	15	9000	11000	17000	19000	23000	26500
160	25	7000	9500	14000	17000	21000	24000
180	30	6000	8000	13500	16000	20000	23000
200	40	4000	6000	11000	13000	17000	21000
225	50	3000	5000	10000	12500	16500	20000
250	60	2500	4000	9000	11500	15000	18000
280	35	2000	3500	-	-	-	-
280	70	-	-	8000	10500	14000	17000
315	35	2000	3500	-	-	-	-
315	90	-	-	6500	8500	12500	16000
355	35	1200	2000	-	-	-	-
355	120	-	-	4200	6000	10000	13000
400	40	1000	1600	-	-	-	-
400	130	-	-	2800	4600	8400	12000
450	40	1000	1600	-	-	-	-
450	140	-	-	2400	4000	8000	8800

Roller bearings: lubrication intervals in duty hours

160	25	3500	4500	7000	8500	10500	12000
180	30	3000	4000	7000	8000	10000	11500
200	40	2000	3000	5500	6500	8500	10500
225	50	1500	2500	5000	6000	8000	10000
250	60	1300	2200	4500	5700	7500	9000
280	35	1000	1800	-	-	-	-
280	70	-	-	4000	5300	7000	8500
315	35	1000	1800	-	-	-	-
315	90	-	-	3300	4300	6000	8000
355	35	600	1000	-	-	-	-
355	120	-	-	2000	3000	5000	6500
400	40	500	800	-	-	-	-
400	130	-	-	1400	2300	4200	6000
450	40	500	800	-	-	-	-
450	140	-	-	1200	2000	4000	4400

Pulley diameter

When the desired bearing life has been determined, the minimum permissible pulley diameter can be calculated using F_R , as follows:

$$D = \frac{1.9 \cdot 10^7 \cdot K \cdot P}{n \cdot F_R}$$

where:

- D = diameter of pulley, mm
- P = power requirement, kW
- n = motor speed, r/min
- K = belt tension factor, dependent on belt type and type of duty. A common value for V-belts is 2.5.
- F_R = permissible radial force

Permissible loadings on shaft

The tables give the permissible radial force in Newtons, assuming zero axial force. The values are based on normal conditions at 50 Hz and calculated bearing lives for motor sizes 71 to 132 of 20,000 hours and for motor sizes 160 to 450 of 20,000 and 40,000 hours.

Motors are foot-mounted IM B3 version with force directed sideways. In some cases the strength of the shaft affects the permissible forces.

At 60 Hz the values must be reduced by 10%. For two-speed motors, the values must be based on the higher speed.

Permissible loads of simultaneous radial and axial forces will be supplied on request.

If the radial force is applied between points X_0 and X_{max} , the permissible force F_R can be calculated from the following formula:

$$F_R = F_{X0} - \frac{X}{E} (F_{X0} - F_{Xmax})$$

E = length of shaft extension in basic version

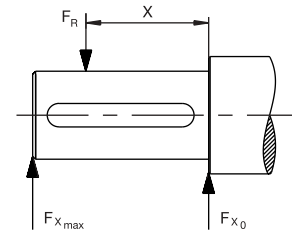

Permissible radial forces

Motor sizes 71 to 132

Motor size	Poles	Length of shaft extension E (mm)	Radial forces Ball bearings			
			20,000 hours		40,000	
			F_{X0} (N)	F_{Xmax} (N)	F_{X0} (N)	F_{Xmax} (N)
71	2	30	381	322	303	256
	4	30	480	405	381	322
	6	30	555	469	441	372
80 M	2	40	624	509	495	404
	4	40	788	643	626	51
	6	40	907	740	720	587
90 S	2	40	686	542	545	430
	4	40	870	687	690	545
	6	40	1000	790	794	627
90 L	2	50	696	564	553	448
	4	50	885	717	702	569
	6	50	1015	823	806	653
100	2	60	979	785	777	622
	4	60	1234	989	979	785
	6	60	1419	1137	1126	903
112	2	60	1258	1014	998	805
	4	60	1592	1284	1264	1019
	6	60	1831	1477	1453	1172
132 S	2	80	1435	1122	1139	890
	4	80	1821	1423	1445	1130
	6	80	2079	1625	1650	1290
132 M	4	80	1840	1476	1461	1172
	6	80	2107	1690	1672	1341

Permissible radial forces

Motor sizes 160 to 450

Motor size	Poles	Length of shaft extension E (mm)	Ball bearings				Roller bearings			
			20,000 hours		40,000 hours		20,000 hours		40,000 hours	
			F_{x0} (N)	F_{xmax} (N)	F_{x0} (N)	F_{xmax} (N)	F_{x0} (N)	F_{xmax} (N)	F_{x0} (N)	F_{xmax} (N)
160	2	110	2980	2310	2350	1810	5530	4260	4370	3360
	4	110	3760	2900	2970	2290	6980	5380	5520	4250
	6	110	4290	3300	3390	2750	7980	6150	6310	4860
	8	110	4730	3660	3740	2880	8800	6780	6960	5360
180	2	110	3540	2880	2790	2260	6260	5080	4940	4010
	4	110	4390	3560	3440	2790	7830	6350	6160	5000
	6	110	5060	4110	3970	3220	9000	7300	7100	5750
	8	110	5590	4540	4390	3560	9940	8060	7830	6350
200 ML_	2	110	4510	3700	3530	2900	8520	7000	6710	5510
	4	110	5660	4650	4430	3640	10710	8800	8440	6930
	6	110	6470	5310	5050	4150	12250	10060	9640	7920
	8	110	7160	5880	5600	5880	13520	11100	10650	8750
225 SM_	2	110	4750	4010	3710	3130	9720	8200	7650	6450
	4	140	6310	5040	4920	3840	12900	10310	10150	8120
	6	140	7200	5760	5620	4500	14740	11800	11600	9280
	8	140	7970	6375	6230	4980	16270	13010	12820	10250
250 SM_	2	140	6100	4910	4750	3830	13600	10960	10710	8640
	4	140	7650	6170	5960	5450	17100	13800	13470	10870
	6	140	8700	7010	6760	5450	19520	15740	15360	12400
	8	140	9630	7760	7505	6050	21550	17380	16970	13690
280 SM_	2	140	7300	6000	5800	4900	20400	6000	16500	6000
	4	140	9200	7800	7300	6200	25100	9200	20300	9200
	6	140	10600	8900	8400	7000	28300	9200	23000	9200
	8	140	11700	9200	9200	7800	30900	9200	25100	9200
315 SM_	2	140	7300	6000	5800	4950	20300	6000	16500	6000
	4	170	11400	9400	9000	7450	32500	9600	26600	9600
	6	170	13000	9600	10300	8500	37000	9600	30000	9600
	8	170	14400	9600	11400	9400	40300	9600	32700	9600
315 ML_	2	140	7400	6400	5850	5050	20600	5850	16700	5850
	4	170	11500	9700	9100	7650	32700	13600	26500	13600
	6	170	13200	11100	10400	8800	36900	13600	29900	13600
	8	170	14500	12200	11500	9700	40200	13600	32600	13600
315 LK_	2	140	7400	6550	5800	5150	20800	5550	16800	5550
	4	170	11500	10000	9100	7850	33100	13350	26800	13350
	6	170	13200	11400	10450	9050	37300	13350	30300	13350
	8	170	14600	12600	11550	10000	40800	13350	33100	13350
355 SM_	2	140	7350	6450	5750	5050	20600	7200	16700	7200
	4	210	15200	12600	12000	9950	45500	14000	36900	14000
	6	210	17500	14000	13800	11400	51400	14000	41700	14000
	8	210	19300	14000	15250	12600	56000	14000	45500	14000
355 ML_	2	140	7350	6550	5750	5100	20800	6750	16800	6750
	4	210	15300	12900	12000	10100	45900	13600	37200	13600
	6	210	17600	13600	13900	11600	51500	13600	42100	13600
	8	210	19400	13600	15300	12900	56000	13600	45900	13600
355 LK_	2	140	7350	6650	5650	5150	21000	6750	17000	6750
	4	210	15200	13000	11850	10200	46000	13000	37300	13000
	6	210	17500	13000	13700	11900	52000	13000	42000	13000
	8	210	19400	13000	15200	13000	56500	13000	46000	13000
400 L_	2	170	7650	6850	4400	3900	23900	9050	19350	9050
	4	210	15600	13550	12150	10550	52500	16000	43300	16000
	6	210	17800	15450	13850	12000	60000	16000	48800	16000
	8	210	19700	16000	15350	13350	65700	16000	53200	16000
400 LK_	2	170	7650	6850	4400	3900	23900	9050	19350	9050
	4	210	15600	11500	12150	10550	52500	11500	43300	11500
	6	210	17800	11500	13850	11500	60000	11500	48800	11500
	8	210	19700	11500	15350	11500	65700	11500	53200	11500
450 L_	2	170	7400	6700	3500	3300	24000	7500	19000	7500
	4	210	17000	15200	13000	11600	62000	25000	50000	25000
	6	210	1900	17000	14000	13000	70000	24000	56000	24000
	8	210	21300	19000	16500	14600	76000	23000	62000	23000

Permissible axial forces

The following tables give the permissible axial forces in Newton, assuming zero radial force. The values are based on normal conditions at 50 Hz with standard bearings and calculated bearing lives of 20,000 and 40,000 hours.

At 60 Hz the values are to be reduced by 10%.

For two-speed motors, the values are to be based on the higher speed. The permissible loads of simultaneous radial and axial forces will be supplied on request.

Given axial forces F_{AD} , assumes D-bearing locked by means of locking ring.

Mounting arrangement IM B3

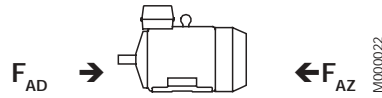

Motor size	20,000 hours								40,000 hours							
	2-pole		4-pole		6-pole		8-pole		2-pole		4-pole		6-pole		8-pole	
	F_{AD} N	F_{AZ} N	F_{AD} N	F_{AZ} N	F_{AD} N	F_{AZ} N	F_{AD} N	F_{AZ} N	F_{AD} N	F_{AZ} N	F_{AD} N	F_{AZ} N	F_{AD} N	F_{AZ} N	F_{AD} N	F_{AZ} N
71	270	270	350	350	440	440	-	-	1)	1)	1)	1)	1)	1)	-	-
80	400	400	510	510	590	590	-	-	1)	1)	1)	1)	1)	1)	-	-
90	450	450	560	560	640	640	-	-	1)	1)	1)	1)	1)	1)	-	-
100	620	620	780	780	890	890	-	-	1)	1)	1)	1)	1)	1)	-	-
112	810	810	1020	1020	1170	1170	-	-	1)	1)	1)	1)	1)	1)	-	-
132 S_	980	980	1220	1220	1400	1400	-	-	1)	1)	1)	1)	1)	1)	-	-
132 M_	980	980	1210	1210	1400	1400	-	-	1)	1)	1)	1)	1)	1)	-	-
160	5240	5240	5230	5230	5220	5220	5240	5240	4650	4650	4630	4630	4630	4630	4740	4740
180	4660	4660	4950	4950	5200	5200	5370	5370	4250	4250	4500	4500	4710	4710	4850	4850
200	3050	3050	3850	3850	4400	4400	4850	4850	2430	2430	3050	3050	3500	3500	3850	3850
225	3440	3440	4340	4340	4960	4960	5460	5460	2730	2730	3440	3440	3940	3940	4340	4340
250	4180	4180	5260	5260	6020	6020	6630	6630	3320	3320	4180	4180	4780	4780	5260	5260
280 SM_	6200	4250	8000	6000	7250	9250	10300	8300	4900	2900	6250	4250	7150	5150	7950	5950
315 SM_	6180	4200	9400	7400	10900	8900	12000	10000	4850	2850	7250	5250	8350	6350	9200	7000
315 ML_	6050	4050	9250	7250	10650	8650	11500	9900	4750	2750	7100	5100	8100	6100	8900	6800
315 LK_	6000	3950	9100	7150	10500	8500	11750	9750	4650	2650	7000	5000	7950	5950	8900	6900
355 SM_	3050	6850	8600	12400	10550	14350	12200	16000	1750	5550	5900	9700	7300	11100	8550	12350
355 ML_	2900	6700	8360	12150	10100	13900	12000	15800	1600	5400	5650	9450	6900	10700	7300	11000
355 LK_	2850	6650	8200	12000	9900	13700	11450	15250	1550	5350	5450	9250	6700	10500	7800	11600
400 L, LK_	2150	7150	7100	13100	8850	14850	10450	16450	1)	5800	4300	10300	5500	11500	6750	12750
450 L_	1800	6800	7600	13500	9000	15000	10800	16800	1)	5500	4500	10500	5600	11500	7000	12900

1) On request

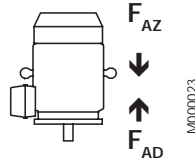

Mounting arrangement IM V1

Motor size	20,000 hours								40,000 hours							
	2-pole		4-pole		6-pole		8-pole		2-pole		4-pole		6-pole		8-pole	
	F_{AD} N	F_{AZ} N	F_{AD} N	F_{AZ} N	F_{AD} N	F_{AZ} N	F_{AD} N	F_{AZ} N	F_{AD} N	F_{AZ} N	F_{AD} N	F_{AZ} N	F_{AD} N	F_{AZ} N	F_{AD} N	F_{AZ} N
71	290	260	380	330	460	420	-	-	1)	1)	1)	1)	1)	1)	-	-
80	430	390	540	490	620	560	-	-	1)	1)	1)	1)	1)	1)	-	-
90	480	420	610	520	700	600	-	-	1)	1)	1)	1)	1)	1)	-	-
100	680	580	880	740	990	840	-	-	1)	1)	1)	1)	1)	1)	-	-
112	890	760	1140	950	1280	1100	-	-	1)	1)	1)	1)	1)	1)	-	-
132 S_	1100	910	1390	1120	1580	1300	-	-	1)	1)	1)	1)	1)	1)	-	-
132 M_	1100	910	1430	1080	1680	1260	-	-	1)	1)	1)	1)	1)	1)	-	-
160	5540	4940	5560	4960	5540	4900	5540	4900	4940	4370	4950	4290	5180	4310	5180	4310
180	5040	4320	5470	4500	5810	4630	5970	4810	4630	3920	4990	4050	5320	4140	5450	4280
200	3600	2500	4580	3120	5280	3530	5720	3980	2970	1870	3780	2320	4370	2620	4720	2980
225	4140	2740	5230	3440	6030	3900	6530	4400	3430	2030	4330	2550	5010	2870	5400	3270
250	5020	3330	6380	4150	7440	4610	8050	5210	4160	2470	5290	3060	6200	3360	6680	3840
280 SM_	7550	3150	9600	4550	11150	5500	12200	7000	6200	1800	7800	2750	9000	3350	9850	4700
315 SM_	7950	2600	11750	5500	13600	6300	15350	7900	6600	1300	9550	3300	11050	3750	12450	5000
315 ML_	8650	2300	12500	5050	14900	5800	15400	6300	7300	1)	10300	2900	12350	3250	13600	3400
315 LK_	9100	1350	13100	3850	15700	4100	16900	6300	7750	1)	10900	1700	13100	1550	14100	3450
355 SM_	6350	4250	13250	8600	15650	9580	17350	12500	4950	2900	10450	5850	12350	6270	13600	8900
355 ML_	7100	3700	14600	7950	18050	8600	21100	11650	5750	2350	11850	5150	14700	5300	17000	7600
355 LK_	7500	3150	15650	6600	19100	7050	21200	8700	6150	1800	12850	3800	15800	3750	17500	5000
400 L, LK_	8650	2150	16050	6400	18450	6750	20100	8350	7220	1)	13150	3400	15100	3400	16450	4700
450 L_	11500	1)	20000	4400	26000	3700	27800	5500	10000	1)	17700	1200	22200	1)	23700	1350

1) On request

Rating plate

For motor sizes 71 to 132 the rating plate gives one current value for the voltage area. That is the highest current that can occur within the voltage area with the given output.

For motor sizes 160 to 450 the rating plate is in table form giving values for speed, current and power factor for six voltages.

Motor sizes 71 to 132

ABB		ABB Motors		CE	
3~Mot. M2BA 132M4A		IEC34-1		3GBA132310-ADA	
620B/C3		6207/C3		IP cl. F	
V	Hz	r/min		cosφ	A
380-420Δ	50	1440	7.5	0.85	15.2
660-690Y	50	1440	7.5	0.85	8.78
440-480Δ	50	1730	8.6	0.86	14.74
No 3010071152				73 kg	

M00283

Motor sizes 160 to 250

ABB		Eff1		CE			
3~Motor M3BP 160 MA 2		IEC 160 M/L 42		No 1)			
		Ins. cl. F		IP55			
V	Hz	kW	r/min	A	cosφ	I _A /I _N	I _F /I _N
690 Y	50	11	2930	11,5	0,88		
400 Δ	50	11	2930	20	0,88		
660 Y	50	11	2915	11,8	0,89		
380 Δ	50	11	2915	20,5	0,89		
415 Δ	50	11	2935	19,4	0,86		
440 Δ	60	14,5	3485	24	0,9		
Prod. code 3GBP 161 101-ADA							
6309/C3		6309/C3		105 kg			
3GZV 163 000-1				IEC 60034-1			

M000216

Motor sizes 160 to 250
Lubrication plate

Regreasing Intervals at 25°C amb. temp. with SHELL ALBIDA EMS2 or acc. to manual.
40°C amb. temp. => 1/2 Intervals

r/min	3600	3000	1800	1500	1000	900
Horizontal motor	7000h	9500h	14000h	17000h	21000h	24000h
Vertical motor	3500h	4750h	7000h	8500h	10500h	12000h

Quantity 25 gr / bearing

3GZV 194 002-115

M000115

Motor sizes 280 to 450
Rating plate

ABB Oy, Electrical Machines		LV Motors, Vaasa, Finland					
CE							
3~Motor M3BP 315 SMB 4 B3		IEC 315 S/M 80					
S1		No. 3291111 7711 SM					
		Ins. cl. F					
		IP 55					
V	Hz	kW	r/min	A	cosφ	Duty	
690 Y	50	160	1487	166	0.85		
400 D	50	160	1487	287	0.85		
660 Y	50	160	1485	171	0.86		
380 D	50	160	1485	296	0.86		
415 D	50	160	1488	279	0.84		
440 D	60	185	1785	295	0.86		
Prod. code 3GBP312230-ADG							
		Nmax 2300 r/min					
6319/C3		6316/C3		1000 kg			
ABB		IEC 60034-1					

M000286

Motor sizes 280 to 450
Lubrication plate

ABB					
Regreasing intervals in duty hours					
Bearings		6319		6316	
Amount of grease		90g		70g	
Mounting	Ambient temp.	1800 r/min	1500 r/min	1000 r/min	500-900 r/min
Hor	25°C	6500	8500	12500	16000
Hor	40°C	3250	4250	6250	8000
Vert	25°C	3250	4250	6250	8000
Vert	40°C	1630	2130	3130	4000
Do not exceed the motor max. speed					
The following or similar high performance grease can be used:					
Esso	Unirex N2, N3 or S2	Mobil	Mobiith SHC 100		
Shell	Albida EMS2	Klüber	Klüberplex BEM 41-132		
SKF	LGHQ 3	FAG	Arcanol TEMP110		
See the "Low Voltage Motors Manual"					

M000287

Ordering information

When placing an order, please state the following minimum data in the order, as in example.

The product code of the motor is composed in accordance with the following example.

Motor type	M3BP 160L
Pole number	2
Mounting arrangement (IM code)	IM B3 (IM 1001)
Rated output	18.5 kW
Product code	3GBP161103-ADA
Variant codes if needed	

Motor size

A	B	C	D. E. F.	G
M3BP	160 L	3GBP 161 103	- A D A	003 etc.
		1 2 3 4 5 6 7 8 9 10 11	12 13 14	

A	Motor type
B	Motor size
C	Product code
D	Mounting arrangement code
E	Voltage and frequency code
F	Generation code
G	Variant codes

Explanation of the product code:

Positions 1 to 4

3GBA/3GBP = Totally enclosed fan cooled squirrel cage motor with cast iron frame

Positions 5 and 6

IEC-frame

07 = 71	20 = 200
08 = 80	22 = 225
09 = 90	25 = 250
10 = 100	28 = 280
11 = 112	31 = 315
13 = 132	35 = 355
16 = 160	40 = 400
18 = 180	45 = 450

Position 7

Speed (Pole pairs)

1 = 2 poles
2 = 4 poles
3 = 6 poles
4 = 8 poles
5 = 10 poles
6 = 12 poles
7 = >12 poles
8 = Two-speed motors for fan drive
9 = Multi-speed motors, two-speed motors for constant torque

Position 8 to 10

Serial number

Position 11

- (dash)

Position 12

Mounting arrangement

A	Foot-mounted, top-mounted terminal box
R	Foot-mounted, terminal box RHS seen from D-end
L	Foot-mounted, terminal box LHS seen from D-end
B	Flange-mounted, large flange
C	Flange-mounted, small flange (sizes 71 to 112)
H	Foot- and flange-mounted, terminal box top-mounted
J	Foot- and flange-mounted, small flange with tapped holes
S	Foot- and flange-mounted, terminal box RHS seen from D-end
T	Foot- and flange-mounted, terminal box LHS seen from D-end
V	Flange-mounted, special flange
F	Foot- and flange-mounted. Special flange

Position 13

Voltage and frequency code

See table below

Position 14

Generation code

A, B, C...

The product code must be, if needed, followed by variant codes.

Code letters for supplementing the product code - single speed motors

Motor size	S		D		H	E		F	T	U	X
	50Hz	60 Hz	50 Hz	60 Hz	50 Hz	50 Hz	60 Hz	50 Hz	50 Hz	50 Hz	
71-132	220-240 VΔ 380-420 VY	440-480 VY	380-420 VΔ 660-690 VY	440-480VΔ	415 VΔ	500 VΔ	575 VΔ	500 VY	660 VΔ	690 VΔ	Other rated voltage, connection or frequency, 690 V maximum
160-450	220, 230 VΔ 380,400,415VY	- 440VY	380, 400, 415 VΔ 660, 690 VY	440VΔ	415 VΔ	500 VΔ	-	500 VY	660 VΔ	690 VΔ	

Code letters for supplementing the product code - two speed motors

Motor size	A	S	B	D	H	E	X
160-450	220 V	230 V	380 V	400 V	415 V	500 V	Other rated voltage, connection or frequency, 690 V maximum

LV Process performance cast iron motors

Technical data for totally enclosed squirrel cage three phase motors



M000111

IP 55 – IC 411 – Insulation class F, temperature rise class B

Output kW	Motor type	Product code	Speed r/min	Efficiency		Power factor cos φ 100%	Current		Torque			
				Full load 100%	3/4 load 75%		I _N A	I _s / I _N	T _N Nm	T _s / T _N	T _{max} / T _N	
3000 r/min = 2-poles				400 V 50 Hz				Basic design				
0.37	M2BA 71 M2 A	3GBA 071 310-••A	2810	71.0	68.1	0.80	0.9	6.1	1.26	2.2	3.0	
0.55	M2BA 71 M2 B	3GBA 071 320-••A	2800	74.0	71.4	0.82	1.3	6.1	1.88	2.2	2.7	
0.75	M2BA 80 M2 A	3GBA 081 310-••A	2850	77.2	75.5	0.86	1.6	6.1	2.51	2.2	3.0	
1.1 ³⁾	M2BA 80 M2 B	3GBA 081 320-••A	2850	80.2	77.6	0.85	2.3	7.0	3.69	2.2	2.2	
1.5 ³⁾	M2BA 90 S2 A	3GBA 091 110-••A	2850	81.6	79.0	0.85	3.1	7.0	5.03	2.2	2.5	
2.2 ³⁾	M2BA 90 L2 A	3GBA 091 510-••A	2850	84.2	81.9	0.84	4.5	7.0	7.37	2.2	3.5	
3 ³⁾	M2BA 100 L2 A	3GBA 101 510-••A	2870	85.1	83.2	0.86	5.9	7.0	9.98	2.2	3.0	
4 ³⁾	M2BA 112 M2 A	3GBA 111 310-••A	2900	86.0	84.5	0.89	7.5	7.0	13.17	2.2	3.2	
5.5 ³⁾	M2BA 132 S2 A	3GBA 131 110-••A	2920	88.6	88.1	0.88	10.2	7.0	17.99	2.2	3.0	
7.5 ³⁾	M2BA 132 S2 B	3GBA 131 120-••A	2920	89.9	88.7	0.89	13.5	7.0	24.53	2.2	3.4	
11	M3BP 160 MA	3GBP 161 101-••A	2930	91.0	91.2	0.88	20	6.2	36	2.1	2.8	
15	M3BP 160 M	3GBP 161 102-••A	2920	91.3	91.7	0.90	26.5	6.4	49	2.3	2.7	
18.5	M3BP 160 L	3GBP 161 103-••A	2920	92.4	93.1	0.91	32	7.2	61	2.6	2.9	
22	M3BP 180 M	3GBP 181 101-••A	2930	92.8	93.3	0.89	38.5	7.2	71	2.7	3.0	
30	M3BP 200 MLA	3GBP 201 001-••A	2955	93.2	93.2	0.88	53	8.5	97	2.9	3.1	
37	M3BP 200 MLB	3GBP 201 002-••A	2950	93.6	93.7	0.89	64	7.2	120	2.3	2.9	
45	M3BP 225 SMB	3GBP 221 001-••A	2960	94.1	93.9	0.88	79	7.7	145	2.5	2.9	
55	M3BP 250 SMA	3GBP 251 001-••A	2970	94.2	93.8	0.89	95	7.9	177	2.4	3.0	
75 ⁴⁾	M3BP 280 SMA	3GBP 281 210-••G	2978	94.8	94.3	0.88	131	7.6	240	2.1	3.0	
90 ⁴⁾	M3BP 280 SMB	3GBP 281 220-••G	2976	95.1	94.8	0.90	152	7.4	289	2.1	2.9	
110 ⁴⁾	M3BP 315 SMA	3GBP 311 210-••G	2982	95.1	94.4	0.86	194	7.6	352	2.0	3.0	
132 ⁴⁾	M3BP 315 SMB	3GBP 311 220-••G	2982	95.5	95.0	0.88	228	7.4	423	2.2	3.0	
160 ⁴⁾	M3BP 315 SMC	3GBP 311 230-••G	2981	96.1	95.6	0.89	269	7.5	513	2.3	3.0	
200 ⁴⁾	M3BP 315 MLA	3GBP 311 410-••G	2980	96.3	95.9	0.90	336	7.7	641	2.6	3.0	
250 ⁴⁾	M3BP 355 SMA	3GBP 351 210-••G	2984	96.4	95.9	0.89	425	7.7	800	2.1	3.3	
315 ⁴⁾	M3BP 355 SMB	3GBP 351 220-••G	2980	96.6	96.3	0.89	535	7.0	1009	2.1	3.0	
355 ⁴⁾	M3BP 355 SMC	3GBP 351 230-••G	2984	96.8	96.5	0.88	604	7.2	1136	2.2	3.0	
400 ²⁾⁴⁾	M3BP 355 MLA	3GBP 351 410-••G	2982	96.9	96.7	0.88	680	7.1	1281	2.3	2.9	
450 ²⁾⁴⁾	M3BP 355 MLB	3GBP 351 420-••G	2983	97.1	97.0	0.90	750	7.9	1441	2.2	2.9	
500 ²⁾⁴⁾	M3BP 355 LKA	3GBP 351 810-••G	2982	97.1	97.0	0.90	830	7.5	1601	2.1	3.5	
560 ²⁾⁴⁾	M3BP 355 LKB	3GBP 351 820-••G	2982	97.2	97.1	0.90	930	8.0	1793	2.3	3.6	
560 ⁵⁾	M3BP 400 LA	3GBP 401 510-••G	2988	97.2	97.0	0.89	940	7.8	1790	2.1	3.4	
560 ⁵⁾⁷⁾	M3BP 400 LKA	3GBP 401 810-••G	2988	97.2	97.0	0.89	940	7.8	1790	2.1	3.4	
630 ⁵⁾	M3BP 400 LB	3GBP 401 520-••G	2987	97.4	97.3	0.89	1055	7.8	2014	2.2	3.4	
630 ⁵⁾⁷⁾	M3BP 400 LKB	3GBP 401 820-••G	2987	97.4	97.3	0.89	1055	7.8	2014	2.2	3.4	
710 ²⁾⁵⁾	M3BP 400 LC	3GBP 401 530-••G	2987	97.5	97.4	0.89	1185	7.8	2270	2.6	3.4	
710 ²⁾⁵⁾⁷⁾	M3BP 400 LKC	3GBP 401 830-••G	2987	97.5	97.4	0.89	1185	7.8	2270	2.6	3.4	
800 ²⁾⁵⁾	M3BP 450 LA	3GBP 451 510-••G	2990	97.3	97.2	0.88	1345	7.8	2555	1.3	3.2	
900 ²⁾⁵⁾	M3BP 450 LB	3GBP 451 520-••G	2990	97.4	97.3	0.88	1515	7.8	2874	1.5	3.1	
1000 ¹⁾⁵⁾⁶⁾	M3BP 450 LC	3GBP 451 530-••G	2990	97.6	97.5	0.89	965	7.8	3194	1.6	3.2	
3000 r/min = 2-poles				400 V 50 Hz				High-output design				
22 ¹⁾	M3BP 160 LB	3GBP 161 104-••A	2920	92.0	93.0	0.91	38	6.9	72	2.3	2.9	
30	M3BP 180 LB	3GBP 181 102-••A	2945	93.7	94.0	0.89	53	7.8	97	2.7	3.0	
45	M3BP 200 MLC	3GBP 201 003-••A	2950	94.1	94.5	0.89	78	8.2	146	3.0	3.2	
55	M3BP 225 SMC	3GBP 221 002-••A	2960	94.5	94.6	0.89	95	7.3	177	2.8	3.0	
75	M3BP 250 SMB	3GBP 251 002-••A	2970	95.0	94.9	0.90	127	8.6	241	2.7	3.3	
90 ¹⁾	M3BP 250 SMC	3GBP 251 230-••G	2965	95.0	94.9	0.90	153	7.7	290	2.6	3.1	
110 ⁴⁾	M3BP 280 SMC	3GBP 281 230-••G	2978	95.7	95.3	0.90	185	7.9	353	2.4	3.0	
250 ²⁾⁴⁾	M3BP 315 LKA	3GBP 311 810-••G	2980	96.5	96.4	0.89	422	8.1	801	2.8	2.9	
315 ¹⁾⁴⁾	M3BP 315 LKC	3GBP 311 830-••G	2981	96.7	96.6	0.89	530	8.8	1009	3.2	3.2	

¹⁾ Temperature rise class F.

²⁾ Temperature rise class F by 380 V 50 Hz.

³⁾ EU efficiency class EFF2; ABB EFF1 motor for these frame sizes is available as an aluminum motor.

⁴⁾ -3dB(A) sound pressure level reduction with unidirectional fan construction. Direction of rotation must be stated when ordering, see variant codes 044 and 045

⁵⁾ Unidirectional fan construction as standard. Direction of rotation must be stated when ordering, see variant codes 044 and 045

⁶⁾ Current at 690 VD 50 Hz (voltage code U), lowest possible voltage 500 VD 50 Hz (voltage code E).

⁷⁾ Size with alternative dimensions

The two bullets in the product code indicate choice of mounting arrangement, voltage and frequency (see ordering information page).

LV Process performance cast iron motors

Technical data for totally enclosed squirrel cage three phase motors

IP 55 – IC 411 – Insulation class F, temperature rise class B

Output kW	Motor type	Speed r/min	Efficiency %	Power factor cos φ	Current I _N A	Speed r/min	Efficiency %	Power factor cos φ	Current I _N A	Moment of inertia J=1/4 GD ² kgm ²	Weight kg	Sound pressure level L _p dB(A)
3000 r/min = 2-poles		380 V 50 Hz				415 V 50 Hz				Basic design		
0.37	M2BA 71 M2 A	2795	71.0	0.83	0.96	2825	71.0	0.78	0.9	0.0003	10	56
0.55	M2BA 71 M2 B	2795	74.0	0.83	1.37	2815	74.0	0.79	1.3	0.0004	11	56
0.75	M2BA 80 M2 A	2835	77.0	0.87	1.7	2865	77.2	0.86	1.6	0.0009	16	57
1.1	³⁾ M2BA 80 M2 B	2835	79.0	0.86	2.46	2865	80.2	0.83	2.3	0.0011	17	58
1.5	³⁾ M2BA 90 S2 A	2835	81.0	0.89	3.17	2865	81.6	0.84	3.1	0.0014	21	61
2.2	³⁾ M2BA 90 L2 A	2835	84.0	0.88	4.53	2865	84.0	0.80	4.6	0.0016	24	61
3	³⁾ M2BA 100 L2 A	2855	85.0	0.88	6.1	2885	85.5	0.84	5.8	0.004	33	65
4	³⁾ M2BA 112 M2 A	2885	86.2	0.89	7.9	2915	86.2	0.86	7.5	0.0067	42	67
5.5	³⁾ M2BA 132 S2 A	2905	88.5	0.89	10.7	2935	88.5	0.87	9.9	0.0124	58	70
7.5	³⁾ M2BA 132 S2 B	2905	88.5	0.89	14.47	2935	90.0	0.89	13.0	0.0149	63	70
11	M3BP 160 MA	2915	90.8	0.89	20.5	2935	91.0	0.86	19.4	0.039	105	69
15	M3BP 160 M	2905	91.0	0.90	27.5	2925	91.4	0.89	25.5	0.047	118	69
18.5	M3BP 160 L	2910	92.0	0.91	33.5	2930	92.6	0.90	31	0.053	133	69
22	M3BP 180 M	2930	92.4	0.90	40.5	2945	93.0	0.88	37.5	0.077	178	69
30	M3BP 200 MLA	2955	93.0	0.89	55	2960	93.3	0.86	52	0.15	250	72
37	M3BP 200 MLB	2950	93.4	0.89	68	2955	93.7	0.87	63	0.18	270	72
45	M3BP 225 SMB	2955	94.0	0.89	82	2965	94.2	0.87	77	0.26	335	74
55	M3BP 250 SMA	2960	94.1	0.89	100	2970	94.2	0.88	92	0.49	420	75
75	⁴⁾ M3BP 280 SMA	2975	94.7	0.89	137	2980	94.8	0.87	127	0.8	625	77
90	⁴⁾ M3BP 280 SMB	2972	95.0	0.90	159	2978	95.1	0.89	148	0.9	665	77
110	⁴⁾ M3BP 315 SMA	2980	95.1	0.87	202	2983	95.1	0.85	190	1.2	880	78
132	⁴⁾ M3BP 315 SMB	2980	95.4	0.89	238	2983	95.5	0.87	222	1.4	940	78
160	⁴⁾ M3BP 315 SMC	2979	96.1	0.90	282	2982	96.1	0.89	262	1.7	1025	78
200	⁴⁾ M3BP 315 MLA	2977	96.3	0.90	354	2982	96.3	0.89	325	2.1	1190	78
250	⁴⁾ M3BP 355 SMA	2982	96.4	0.90	445	2985	96.4	0.88	412	3	1600	83
315	⁴⁾ M3BP 355 SMB	2978	96.5	0.89	560	2982	96.6	0.89	515	3.4	1680	83
355	⁴⁾ M3BP 355 SMC	2981	96.8	0.89	632	2985	96.8	0.88	582	3.6	1750	83
400	^{2) 4)} M3BP 355 MLA	2980	96.9	0.89	710	2984	96.9	0.87	660	4.1	2000	83
450	^{2) 4)} M3BP 355 MLB	2980	97.0	0.91	785	2985	97.1	0.90	720	4.3	2080	83
500	^{2) 4)} M3BP 355 LKA	2979	97.0	0.91	870	2984	97.1	0.90	800	4.8	2320	83
560	^{2) 4)} M3BP 355 LKB	2980	97.1	0.91	980	2984	97.2	0.90	895	5.2	2460	83
560	⁵⁾ M3BP 400 LA	2986	97.2	0.90	980	2989	97.2	0.88	910	7.9	2950	82
560	^{5) 7)} M3BP 400 LKA	2986	97.2	0.90	980	2989	97.2	0.88	910	7.9	2950	82
630	⁵⁾ M3BP 400 LB	2985	97.4	0.90	1100	2988	97.4	0.88	1015	8.2	3050	82
630	^{5) 7)} M3BP 400 LKB	2985	97.4	0.90	1100	2988	97.4	0.88	1015	8.2	3050	82
710	^{2) 5)} M3BP 400 LC	2985	97.4	0.90	1230	2988	97.5	0.89	1140	9.3	3300	82
710	^{2) 5) 7)} M3BP 400 LKC	2985	97.4	0.90	1230	2988	97.5	0.89	1140	9.3	3300	82
800	^{2) 5)} M3BP 450 LA	2989	97.3	0.89	1400	2991	97.4	0.87	1310	12.5	4000	85
900	^{2) 5)} M3BP 450 LB	2989	97.4	0.89	1575	2991	97.4	0.88	1460	14	4200	85
1000	^{1) 5) 6)} M3BP 450 LC	-	-	-	-	-	-	-	-	15.5	4400	85
3000 r/min = 2-poles		3000 r/min = 2-poles				380 V 50 Hz				415 V 50 Hz		
22	¹⁾ M3BP 160 LB	2910	91.6	0.91	40	2925	92.4	0.90	37	0.058	140	69
30	M3BP 180 LB	2940	93.9	0.90	55	2950	93.8	0.87	52	0.092	194	70
45	M3BP 200 MLC	2945	94.0	0.89	82	2955	94.2	0.88	76	0.19	280	72
55	M3BP 225 SMC	2950	94.3	0.89	100	2965	94.7	0.88	92	0.29	355	74
75	¹⁾ M3BP 250 SMB	2965	94.6	0.90	134	2970	94.7	0.89	123	0.57	465	75
90	¹⁾ M3BP 250 SMC	2960	94.9	0.88	160	2968	95.0	0.89	148	0.59	475	80
110	⁴⁾ M3BP 280 SMC	2974	95.6	0.91	194	2980	95.7	0.90	179	1.15	725	77
250	^{2) 4)} M3BP 315 LKA	2977	96.3	0.89	444	2982	96.5	0.89	408	2.65	1440	78
315	^{1) 4)} M3BP 315 LKC	2978	96.7	0.90	552	2983	96.8	0.89	508	3.3	1630	78

LV Process performance cast iron motors

Technical data for totally enclosed squirrel cage three phase motors

IP 55 – IC 411 – Insulation class F, temperature rise class B

Output kW	Motor type	Product code	Speed r/min	Efficiency		Power factor cos φ	Current		Torque			
				Full load 100%	3/4 load 75%		I _N	I _s	T _N	T _s	T _{max}	
				400 V 50 Hz				Basic design				
0.25	M2BA 71 M4 A	3GBA 072 310-••A	1390	66.3	63.3	0.73	0.8	5.2	1.72	2.1	2.7	
0.37	M2BA 71 M4 B	3GBA 072 320-••A	1380	70.8	69.4	0.75	1.0	5.2	2.56	2.1	2.6	
0.55	M2BA 80 M4 A	3GBA 082 310-••A	1410	75.0	72.4	0.73	1.5	5.2	3.73	2.4	2.7	
0.75	M2BA 80 M4 B	3GBA 082 320-••A	1400	76.3	75.1	0.76	1.9	6.0	5.12	2.4	2.6	
1.1 ³⁾	M2BA 90 S4 A	3GBA 092 110-••A	1400	78.5	77.8	0.78	2.6	6.0	7.5	2.3	2.4	
1.5 ³⁾	M2BA 90 L4 A	3GBA 092 510-••A	1390	80.5	79.2	0.78	3.5	6.0	10.31	2.3	2.6	
2.2 ³⁾	M2BA 100 L4 A	3GBA 102 510-••A	1430	82.5	81.7	0.80	4.8	6.0	14.69	2.3	2.7	
3 ³⁾	M2BA 100 L4 B	3GBA 102 520-••A	1420	84.5	82.5	0.82	6.3	6.5	20.18	2.3	2.8	
4 ³⁾	M2BA 112 M4 A	3GBA 112 310-••A	1430	86.0	84.7	0.81	8.2	6.5	26.71	2.3	2.8	
5.5 ³⁾	M2BA 132 S4 A	3GBA 132 110-••A	1430	87.4	87.1	0.84	10.8	6.5	36.73	2.3	2.9	
7.5 ³⁾	M2BA 132 M4 A	3GBA 132 310-••A	1440	89.0	88.7	0.85	14.3	6.5	49.74	2.3	2.7	
11	M3BP 160 M	3GBP 162 101-••A	1460	92.0	92.7	0.81	21.5	7.6	72	2.9	3.4	
15	M3BP 160 L	3GBP 162 102-••A	1460	91.8	92.5	0.82	29.0	8.1	98	3.3	3.6	
18.5	M3BP 180 M	3GBP 182 101-••A	1470	92.3	92.9	0.84	35	7.0	120	2.9	2.9	
22	M3BP 180 L	3GBP 182 102-••A	1470	93.1	93.9	0.85	40	7.0	143	2.6	2.8	
30	M3BP 200 MLB	3GBP 202 001-••A	1475	93.4	94.0	0.84	55	7.5	194	2.5	2.8	
37	M3BP 225 SMA	3GBP 222 001-••A	1480	93.6	93.8	0.84	68	7.4	239	2.9	3.0	
45	M3BP 225 SMB	3GBP 222 002-••A	1480	94.2	94.4	0.83	83	7.6	291	2.8	3.0	
55	M3BP 250 SMA	3GBP 252 001-••A	1480	94.6	94.9	0.86	98	7.6	355	3.1	3.0	
75	M3BP 280 SMA	3GBP 282 210-••G	1484	94.9	94.8	0.85	135	6.9	483	2.5	2.8	
90	M3BP 280 SMB	3GBP 282 220-••G	1483	95.3	95.3	0.86	159	7.2	580	2.5	2.7	
110	M3BP 315 SMA	3GBP 312 210-••G	1487	95.6	95.4	0.86	193	7.2	706	2.0	2.5	
132	M3BP 315 SMB	3GBP 312 220-••G	1487	95.8	95.7	0.86	232	7.1	848	2.3	2.7	
160	M3BP 315 SMC	3GBP 312 230-••G	1487	96.0	95.9	0.85	287	7.2	1028	2.4	2.9	
200	M3BP 315 MLA	3GBP 312 410-••G	1486	96.2	96.2	0.86	351	7.2	1285	2.5	2.9	
250	M3BP 355 SMA	3GBP 352 210-••G	1488	96.5	96.4	0.86	438	7.1	1604	2.3	2.7	
315	M3BP 355 SMB	3GBP 352 220-••G	1488	96.7	96.6	0.86	550	7.3	2022	2.3	2.8	
355 ²⁾	M3BP 355 SMC	3GBP 352 230-••G	1487	96.7	96.6	0.86	616	6.8	2280	2.4	2.7	
400 ²⁾	M3BP 355 MLA	3GBP 352 410-••G	1489	96.9	96.7	0.85	700	6.8	2565	2.3	2.6	
450 ²⁾	M3BP 355 MLB	3GBP 352 420-••G	1490	96.9	96.7	0.86	784	6.9	2884	2.3	2.9	
500	M3BP 355 LKA	3GBP 352 810-••G	1490	97.0	96.9	0.86	875	6.8	3204	2.0	3.0	
560 ¹⁾	M3BP 355 LKB	3GBP 352 820-••G	1490	96.9	96.9	0.85	990	7.2	3589	2.6	2.7	
560 ²⁾⁴⁾	M3BP 400 LKA	3GBP 402 810-••G	1491	97.1	97.0	0.85	980	7.4	3587	2.4	3.0	
560 ²⁾	M3BP 400 LA	3GBP 402 510-••G	1491	97.1	97.0	0.85	980	7.4	3587	2.4	3.0	
630 ²⁾	M3BP 400 LB	3GBP 402 520-••G	1491	97.1	97.0	0.87	1085	7.6	4035	2.2	3.1	
630 ²⁾⁴⁾	M3BP 400 LKB	3GBP 402 820-••G	1491	97.1	97.0	0.87	1085	7.6	4035	2.2	3.1	
710 ¹⁾	M3BP 400 LC	3GBP 402 530-••G	1491	97.2	97.1	0.86	1240	7.6	4547	2.4	3.2	
710 ¹⁾⁴⁾	M3BP 400 LKC	3GBP 402 830-••G	1491	97.2	97.1	0.86	1240	7.6	4547	2.4	3.2	
800	M3BP 450 LA	3GBP 452 510-••G	1492	97.0	96.9	0.86	1385	7.0	5120	1.3	2.8	
900 ²⁾	M3BP 450 LB	3GBP 452 520-••G	1492	97.1	97.0	0.86	1555	7.0	5760	1.3	2.8	
1000 ¹⁾	M3BP 450 LC	3GBP 452 530-••G	1491	97.2	97.1	0.86	1725	6.8	6405	1.3	2.7	
1500 r/min = 4-poles				400 V 50 Hz				High-output design				
18.5 ¹⁾	M3BP 160 LB	3GBP 162 103-••A	1450	90.5	92.0	0.84	36	6.6	122	2.6	3.0	
30 ¹⁾	M3BP 180 LB	3GBP 182 103-••A	1465	92.5	93.3	0.84	56	6.8	196	2.5	2.8	
37	M3BP 200 MLB	3GBP 202 002-••A	1475	93.4	94.0	0.84	68	7.9	240	3.8	3.2	
55	M3BP 225 SMC	3GBP 222 003-••A	1480	94.6	95.0	0.84	100	7.5	356	3.5	3.0	
75	M3BP 250 SMB	3GBP 252 002-••A	1480	94.8	95.3	0.86	132	7.1	486	3.2	3.0	
110	M3BP 280 SMC	3GBP 282 230-••G	1485	95.7	95.7	0.86	195	7.6	707	3.0	3.0	
250 ²⁾	M3BP 315 LKA	3GBP 312 810-••G	1487	96.2	96.2	0.86	442	7.4	1605	2.5	2.9	
280 ²⁾	M3BP 315 LKB	3GBP 312 820-••G	1487	96.5	96.4	0.87	482	7.6	1798	2.6	3.0	
315 ²⁾	M3BP 315 LKC	3GBP 312 830-••G	1488	96.5	96.4	0.86	548	7.8	2022	2.6	3.2	

¹⁾ Temperature rise class F.

²⁾ Temperature rise class F by 380 V 50 Hz.

³⁾ EU efficiency class EFF2; ABB EFF1 motor for these frame sizes is available as an aluminum motor.

⁴⁾ Size with alternative dimensions

The two bullets in the product code indicate choice of mounting arrangement, voltage and frequency (see ordering information page).

LV Process performance cast iron motors

Technical data for totally enclosed squirrel cage three phase motors

IP 55 – IC 411 – Insulation class F, temperature rise class B

Output kW	Motor type	Speed r/min	Efficiency %	Power factor cos φ	Current I _N A	Speed r/min	Efficiency %	Power factor cos φ	Current I _N A	Moment of inertia J=1/4 GD ² kgm ²	Weight kg	Sound pressure level L _p dB(A)
1500 r/min = 4-poles			1500 r/min = 4-poles			380 V 50 Hz			415 V 50 Hz			
0.25	M2BA 71 M4 A	1380	66.5	0.76	0.76	1400	65.0	0.71	0.8	0.0005	11	43
0.37	M2BA 71 M4 B	1370	70.5	0.78	1.02	1390	70.5	0.71	1	0.0007	11	45
0.55	M2BA 80 M4 A	1400	75.0	0.76	1.47	1420	74.0	0.69	1.5	0.0014	16	46
0.75	M2BA 80 M4 B	1390	76.0	0.78	1.93	1410	75.5	0.73	1.9	0.0017	17	46
1.1	³⁾ M2BA 90 S4 A	1390	78.0	0.81	2.65	1410	78.5	0.75	2.6	0.0025	21	52
1.5	³⁾ M2BA 90 L4 A	1380	80.0	0.80	3.57	1400	80.5	0.75	3.5	0.0037	26	52
2.2	³⁾ M2BA 100 L4 A	1420	81.5	0.83	4.95	1440	82.5	0.77	4.8	0.0068	32	53
3	³⁾ M2BA 100 L4 B	1410	84.0	0.84	6.46	1430	84.5	0.80	6.2	0.0086	36	53
4	³⁾ M2BA 112 M4 A	1420	85.5	0.83	8.52	1440	86.0	0.78	8.2	0.0131	45	56
5.5	³⁾ M2BA 132 S4 A	1420	86.5	0.86	11.24	1440	87.5	0.83	10.6	0.0267	60	59
7.5	³⁾ M2BA 132 M4 A	1430	88.4	0.85	15.2	1450	88.7	0.84	14	0.0343	73	59
11	M3BP 160 M	1460	91.1	0.83	22.5	1470	91.6	0.82	20.5	0.091	115	62
15	M3BP 160 L	1455	91.8	0.84	30	1465	91.9	0.81	28	0.102	135	62
18.5	M3BP 180 M	1465	91.7	0.85	36	1470	92.2	0.83	34	0.161	175	62
22	M3BP 180 L	1465	92.7	0.86	42	1475	93.3	0.84	38	0.225	203	63
30	M3BP 200 MLB	1470	93.1	0.85	58	1475	93.5	0.84	54	0.34	275	63
37	M3BP 225 SMA	1475	93.6	0.84	72	1480	93.8	0.81	68	0.37	310	66
45	M3BP 225 SMB	1475	94.0	0.85	86	1480	94.2	0.81	82	0.42	330	66
55	M3BP 250 SMA	1475	94.4	0.86	103	1480	94.5	0.84	96	0.72	420	67
75	M3BP 280 SMA	1482	94.7	0.86	141	1486	94.9	0.84	132	1.25	625	68
90	M3BP 280 SMB	1481	95.2	0.87	166	1485	95.3	0.85	155	1.5	665	68
110	M3BP 315 SMA	1486	95.5	0.87	202	1488	95.6	0.85	191	2.3	900	70
132	M3BP 315 SMB	1486	95.7	0.87	242	1488	95.8	0.85	227	2.6	960	70
160	M3BP 315 SMC	1485	95.9	0.86	296	1488	96.0	0.84	279	2.9	1000	70
200	²⁾ M3BP 315 MLA	1484	96.1	0.87	366	1488	96.2	0.85	342	3.5	1160	70
250	M3BP 355 SMA	1487	96.4	0.87	455	1489	96.5	0.85	430	5.9	1610	74
315	M3BP 355 SMB	1487	96.7	0.87	571	1489	96.7	0.85	538	6.9	1780	74
355	²⁾ M3BP 355 SMC	1485	96.5	0.87	645	1488	96.7	0.85	608	7.2	1820	78
400	²⁾ M3BP 355 MLA	1488	96.8	0.86	740	1490	96.9	0.84	685	8.4	2140	78
450	²⁾ M3BP 355 MLB	1488	96.8	0.87	825	1491	96.9	0.84	770	8.4	2140	78
500	M3BP 355 LKA	1489	97.0	0.87	907	1491	97.0	0.85	852	10	2500	78
560	¹⁾ M3BP 355 LKB	1488	96.9	0.86	1020	1491	97.0	0.84	960	10.6	2600	78
560	²⁾⁴⁾ M3BP 400 LKA	1490	97.0	0.86	1020	1492	97.1	0.84	970	15	3200	78
560	²⁾ M3BP 400 LA	1490	97.0	0.86	1020	1492	97.1	0.84	970	15	3200	78
630	²⁾ M3BP 400 LB	1490	97.0	0.88	1130	1492	97.1	0.86	1055	16	3300	78
630	²⁾⁴⁾ M3BP 400 LKB	1490	97.0	0.88	1130	1492	97.1	0.86	1055	16	3300	78
710	¹⁾ M3BP 400 LC	1490	97.1	0.87	1290	1492	97.2	0.84	1215	17	3400	78
710	¹⁾⁴⁾ M3BP 400 LKC	1490	97.1	0.87	1290	1492	97.2	0.84	1215	17	3400	78
800	M3BP 450 LA	1491	96.9	0.87	1440	1492	97.0	0.85	1350	23	4050	85
900	²⁾ M3BP 450 LB	1491	97.1	0.87	1620	1492	97.1	0.85	1515	25	4350	85
1000	¹⁾ M3BP 450 LC	1490	97.1	0.87	1800	1492	97.2	0.85	1680	30	4700	85
1500 r/min = 4-poles			1500 r/min = 4-poles			380 V 50 Hz			415 V 50 Hz			
18.5	¹⁾ M3BP 160 LB	1440	89.8	0.85	37	1450	90.8	0.83	34	0.102	135	63
30	¹⁾ M3BP 180 LB	1465	92.2	0.85	58	1470	92.7	0.82	55	0.225	203	63
37	M3BP 200 MLB	1475	93.3	0.85	71	1475	93.3	0.82	67	0.34	275	63
55	M3BP 225 SMC	1475	94.3	0.84	105	1480	94.6	0.82	99	0.49	355	66
75	¹⁾ M3BP 250 SMB	1475	94.5	0.87	139	1480	94.8	0.86	128	0.88	465	67
110	M3BP 280 SMC	1483	95.6	0.87	202	1486	95.7	0.85	189	1.85	725	68
250	²⁾ M3BP 315 LKA	1485	96.1	0.87	457	1488	96.3	0.85	428	4.4	1410	78
280	²⁾ M3BP 315 LKB	1485	96.3	0.88	502	1488	96.5	0.86	470	5	1520	78
315	²⁾ M3BP 315 LKC	1486	96.4	0.87	570	1489	96.5	0.85	535	5.5	1600	78

LV Process performance cast iron motors

Technical data for totally enclosed squirrel cage three phase motors

IP 55 – IC 411 – Insulation class F, temperature rise class B

Output kW	Motor type	Product code	Speed r/min	Efficiency		Power factor cos φ 100%	Current		Torque			
				Full load 100%	3/4 load 75%		I _N A	I _s / I _N	T _N Nm	T _s / T _N	T _{max} / T _N	
1000 r/min = 6-poles				400 V 50 Hz				Basic design				
0.18	M2BA 71 M6 A	3GBA 073 310-••A	880	57.0	50.4	0.63	0.7	4.0	1.95	1.7	2.4	
0.25	M2BA 71 M6 B	3GBA 073 320-••A	880	61.5	58.3	0.65	0.9	4.0	2.71	1.7	2.5	
0.37	M2BA 80 M6 A	3GBA 083 310-••A	920	68.0	63.2	0.65	1.2	5.0	3.84	1.7	2.0	
0.55	M2BA 80 M6 B	3GBA 083 320-••A	920	70.0	65.1	0.66	1.7	5.0	5.71	1.7	1.8	
0.75	M2BA 90 S6 A	3GBA 093 110-••A	920	74.0	70.2	0.71	2.1	5.0	7.79	2.0	2.3	
1.1	M2BA 90 L6 A	3GBA 093 510-••A	920	75.0	73.1	0.73	2.9	5.0	11.42	2.0	2.6	
1.5	M2BA 100 L6 A	3GBA 103 510-••A	930	79.0	75.5	0.73	3.8	5.5	15.4	2.0	2.4	
2.2	M2BA 112 M6 A	3GBA 113 310-••A	940	83.0	81.1	0.73	5.2	5.5	22.35	2.0	2.3	
3	M2BA 132 S6 A	3GBA 133 110-••A	960	84.5	82.4	0.77	6.7	6.5	29.84	2.0	2.4	
4	M2BA 132 M6 A	3GBA 133 310-••A	960	85.0	84.1	0.76	8.9	6.5	39.79	2.0	2.9	
5.5	M2BA 132 M6 B	3GBA 133 320-••A	950	87.0	85.9	0.78	11.7	6.5	55	2.0	3.0	
7.5	M3BP 160 M	3GBP 163 101-••A	970	89.3	90.4	0.79	15.4	6.6	74	1.9	2.6	
11	M3BP 160 L	3GBP 163 102-••A	970	89.8	90.5	0.78	23	6.9	109	2.1	3.4	
15	M3BP 180 L	3GBP 183 101-••A	970	90.8	91.5	0.78	31	6.8	147	2.0	3.3	
18.5	M3BP 200 MLA	3GBP 203 001-••A	985	91.1	91.7	0.81	36	7.0	180	2.7	2.5	
22	M3BP 200 MLB	3GBP 203 002-••A	980	91.7	92.2	0.81	43	6.8	214	2.9	3.0	
30	M3BP 225 SMB	3GBP 223 001-••A	985	92.8	93.0	0.83	56	7.2	291	3.1	2.9	
37	M3BP 250 SMA	3GBP 253 001-••A	985	93.4	93.7	0.83	69	7.3	358	3.1	2.8	
45	M3BP 280 SMA	3GBP 283 210-••G	990	94.4	94.3	0.84	82	7.0	434	2.5	2.5	
55	M3BP 280 SMB	3GBP 283 220-••G	990	94.6	94.6	0.84	101	7.0	531	2.7	2.6	
75	M3BP 315 SMA	3GBP 313 210-••G	992	95.0	94.7	0.82	141	7.4	722	2.4	2.8	
90	M3BP 315 SMB	3GBP 313 220-••G	992	95.5	95.3	0.84	163	7.5	866	2.4	2.8	
110	M3BP 315 SMC	3GBP 313 230-••G	991	95.6	95.5	0.83	202	7.4	1060	2.5	2.9	
132	M3BP 315 MLA	3GBP 313 410-••G	991	95.8	95.7	0.83	240	7.5	1272	2.7	3.0	
160	M3BP 355 SMA	3GBP 353 210-••G	993	96.0	95.8	0.83	293	7.0	1539	2.0	2.6	
200	M3BP 355 SMB	3GBP 353 220-••G	993	96.2	96.1	0.84	357	7.2	1923	2.2	2.7	
250	M3BP 355 SMC	3GBP 353 230-••G	993	96.5	96.3	0.83	450	7.4	2404	2.6	2.9	
315	M3BP 355 MLB	3GBP 353 420-••G	992	96.4	96.3	0.83	570	7.0	3032	2.5	2.7	
355 ²⁾	M3BP 355 LKA	3GBP 353 810-••G	992	96.6	96.5	0.83	640	7.6	3417	2.7	2.9	
400 ¹⁾	M3BP 355 LKB	3GBP 353 820-••G	992	96.4	96.4	0.83	722	7.2	3851	2.6	2.6	
400	M3BP 400 LA	3GBP 403 510-••G	993	96.7	96.6	0.82	730	7.1	3847	2.3	2.7	
400 ³⁾	M3BP 400 LKA	3GBP 403 810-••G	993	96.7	96.6	0.82	730	7.1	3847	2.3	2.7	
450 ^{2) 3)}	M3BP 400 LKB	3GBP 403 820-••G	994	96.9	96.7	0.82	818	7.4	4323	2.4	2.8	
450 ²⁾	M3BP 400 LB	3GBP 403 520-••G	994	96.9	96.7	0.82	818	7.4	4323	2.4	2.8	
500 ^{2) 3)}	M3BP 400 LKC	3GBP 403 830-••G	993	96.9	96.8	0.83	900	7.2	4808	2.5	2.7	
500 ²⁾	M3BP 400 LC	3GBP 403 530-••G	993	96.9	96.8	0.83	900	7.2	4808	2.5	2.7	
560 ^{2) 3)}	M3BP 400 LKD	3GBP 403 840-••G	993	96.9	96.8	0.85	985	7.4	5385	2.4	3.0	
560 ²⁾	M3BP 400 LD	3GBP 403 540-••G	993	96.9	96.8	0.85	985	7.4	5385	2.4	3.0	
630	M3BP 450 LA	3GBP 453 510-••G	994	97.0	97.0	0.84	1115	6.5	6052	1.1	2.5	
710	M3BP 450 LB	3GBP 453 520-••G	995	97.1	97.1	0.85	1240	7.0	6814	1.3	2.5	
800 ¹⁾	M3BP 450 LC	3GBP 453 530-••G	995	97.1	97.1	0.84	1415	7.2	7678	1.3	2.7	
1000 r/min = 6-poles				400 V 50 Hz				High-output design				
14 ¹⁾	M3BP 160 LB	3GBP 163 103-••A	960	89.8	90.1	0.77	29.5	7.0	138	2.5	3.1	
18.5 ¹⁾	M3BP 180 LB	3GBP 183 102-••A	965	90.7	91.7	0.80	37	6.1	183	2.1	2.5	
30 ¹⁾	M3BP 200 MLC	3GBP 203 003-••A	980	91.7	92.4	0.81	56	7.3	296	3.6	2.9	
37	M3BP 225 SMC	3GBP 223 002-••A	985	93.0	93.6	0.83	69	7.3	360	3.6	2.8	
45 ¹⁾	M3BP 250 SMB	3GBP 253 002-••A	985	93.4	93.7	0.84	83	7.2	436	3.2	2.8	
75	M3BP 280 SMC	3GBP 283 230-••G	990	95.1	95.2	0.84	137	7.3	723	2.8	2.7	
160	M3BP 315 LKA	3GBP 313 810-••G	992	95.8	95.7	0.83	293	7.5	1540	2.6	2.8	
180	M3BP 315 LKB	3GBP 313 820-••G	992	95.9	95.8	0.83	330	7.4	1733	2.6	2.8	
200	M3BP 315 LKC	3GBP 313 830-••G	989	95.7	95.7	0.84	362	6.8	1931	2.5	2.6	

¹⁾ Temperature rise class F.

²⁾ Temperature rise class F by 380 V 50 Hz.

³⁾ Size with alternative dimensions

The two bullets in the product code indicate choice of mounting arrangement, voltage and frequency (see ordering information page).

LV Process performance cast iron motors

Technical data for totally enclosed squirrel cage three phase motors

IP 55 – IC 411 – Insulation class F, temperature rise class B

Output kW	Motor type	Speed r/min	Efficiency %	Power factor cos φ	Current I _N A	Speed r/min	Efficiency %	Power factor cos φ	Current I _N A	Moment of inertia J=1/4 GD ² kgm ²	Weight kg	Sound pressure level L _p dB(A)
1000 r/min = 6-poles			1000 r/min = 6-poles			380 V 50 Hz			415 V 50 Hz			
0.18	M2BA 71 M6 A	875	57.5	0.67	0.71	885	54.0	0.61	0.8	0.0006	10	42
0.25	M2BA 71 M6 B	875	61.5	0.65	0.95	885	61.0	0.62	0.9	0.0007	11	42
0.37	M2BA 80 M6 A	915	68.0	0.68	1.22	925	66.7	0.61	1.3	0.0016	17	45
0.55	M2BA 80 M6 B	915	70.0	0.68	1.76	925	71.0	0.62	1.7	0.002	18	45
0.75	M2BA 90 S6 A	915	73.5	0.75	2.08	925	73.5	0.67	2.1	0.0029	21	48
1.1	M2BA 90 L6 A	915	74.0	0.78	2.9	925	75.0	0.75	2.9	0.0038	25	48
1.5	M2BA 100 L6 A	925	78.0	0.78	3.75	935	78.8	0.71	3.7	0.01	32	51
2.2	M2BA 112 M6 A	935	82.0	0.75	5.44	945	83.0	0.72	5.1	0.0156	40	54
3	M2BA 132 S6 A	955	83.5	0.80	6.83	965	84.5	0.75	6.6	0.0312	55	56
4	M2BA 132 M6 A	955	85.0	0.76	9.41	965	85.2	0.74	8.8	0.0407	65	56
5.5	M2BA 132 M6 B	945	86.5	0.79	12.24	955	87.5	0.77	11.4	0.0533	75	56
7.5	M3BP 160 M	960	88.7	0.80	16.1	970	89.6	0.77	15.1	0.089	115	59
11	M3BP 160 L	960	89.4	0.80	23.5	970	90.0	0.76	22.5	0.107	135	59
15	M3BP 180 L	970	90.9	0.79	32	975	91.1	0.74	30.5	0.217	177	59
18.5	M3BP 200 MLA	980	90.8	0.81	38	985	91.1	0.78	36	0.37	245	63
22	M3BP 200 MLB	980	91.6	0.81	45	985	91.8	0.79	42	0.43	260	63
30	M3BP 225 SMB	985	92.6	0.83	59	985	92.9	0.82	55	0.64	320	63
37	M3BP 250 SMA	985	93.3	0.84	72	990	93.5	0.81	67	1.16	415	63
45	M3BP 280 SMA	989	94.2	0.84	87	991	94.4	0.82	81	1.85	605	66
55	M3BP 280 SMB	988	94.5	0.84	106	991	94.6	0.83	99	2.2	645	66
75	M3BP 315 SMA	991	94.9	0.84	145	993	95.0	0.79	140	3.2	830	70
90	M3BP 315 SMB	991	95.4	0.85	169	993	95.5	0.82	160	4.1	930	70
110	M3BP 315 SMC	990	95.5	0.84	211	992	95.6	0.82	197	4.9	1000	70
132	M3BP 315 MLA	990	95.7	0.84	250	992	95.8	0.82	236	5.8	1150	68
160	M3BP 355 SMA	992	95.9	0.84	305	994	96.0	0.82	285	7.9	1520	75
200	M3BP 355 SMB	992	96.1	0.85	372	994	96.2	0.83	350	9.7	1680	75
250	M3BP 355 SMC	992	96.4	0.84	470	994	96.5	0.81	446	11.3	1820	75
315	M3BP 355 MLB	991	96.3	0.84	592	993	96.4	0.82	556	13.5	2180	75
355 ²⁾	M3BP 355 LKA	991	96.5	0.84	665	993	96.6	0.81	632	15.5	2500	75
400 ¹⁾	M3BP 355 LKB	991	96.4	0.84	752	993	96.5	0.81	712	16.5	2600	75
400	M3BP 400 LA	992	96.7	0.83	760	994	96.7	0.80	720	17	2900	76
400 ³⁾	M3BP 400 LKA	992	96.7	0.83	760	994	96.7	0.80	720	17	2900	76
450 ²⁾³⁾	M3BP 400 LKB	993	96.8	0.84	850	994	96.9	0.80	815	20.5	3150	76
450 ²⁾	M3BP 400 LB	993	96.8	0.84	850	994	96.9	0.80	815	20.5	3150	76
500 ²⁾³⁾	M3BP 400 LKC	992	96.8	0.84	940	994	96.9	0.82	888	22	3300	76
500 ²⁾	M3BP 400 LC	992	96.8	0.84	940	994	96.9	0.82	888	22	3300	76
560 ²⁾³⁾	M3BP 400 LKD	992	96.8	0.86	1035	994	96.9	0.83	970	24	3400	77
560 ²⁾	M3BP 400 LD	992	96.8	0.86	1035	994	96.9	0.83	970	24	3400	77
630	M3BP 450 LA	993	96.9	0.85	1160	995	97.0	0.83	1090	31	4150	81
710	M3BP 450 LB	994	97.0	0.86	1295	995	97.1	0.84	1210	37	4500	81
800 ¹⁾	M3BP 450 LC	994	97.1	0.85	1470	995	97.1	0.83	1380	41	4800	81
1000 r/min = 6-poles			1000 r/min = 6-poles			380 V 50 Hz			415 V 50 Hz			
14 ¹⁾	M3BP 160 LB	955	89.7	0.79	30.5	965	89.6	0.75	29.5	0.127	148	62
18.5 ¹⁾	M3BP 180 LB	960	90.1	0.82	38	970	90.9	0.79	36	0.237	185	59
30 ¹⁾	M3BP 200 MLC	980	91.5	0.83	57	985	91.9	0.83	52	0.49	275	63
37 ¹⁾	M3BP 225 SMC	980	92.7	0.83	72	985	93.2	0.81	68	0.75	345	63
45 ¹⁾	M3BP 250 SMB	985	93.5	0.84	87	985	93.6	0.83	81	1.49	460	63
75	M3BP 280 SMC	988	95.0	0.85	142	991	95.2	0.83	132	2.85	725	66
160	M3BP 315 LKA	991	95.7	0.84	304	992	95.8	0.82	285	7.3	1410	74
180	M3BP 315 LKB	990	95.8	0.84	342	992	95.9	0.82	321	8.3	1520	74
200	M3BP 315 LKC	988	95.6	0.84	380	990	95.9	0.83	353	9.2	1600	74

LV Process performance cast iron motors

Technical data for totally enclosed squirrel cage three phase motors

IP 55 – IC 411 – Insulation class F, temperature rise class B

Output kW	Motor type	Product code	Speed r/min	Efficiency		Power factor cos φ	Current		Torque			
				Full load 100%	3/4 load 75%		I _N	I _s	T _N	T _s	T _{max}	
							A	I _N	Nm	T _N	T _N	
750 r/min = 8-poles			400 V 50 Hz				Basic design					
4	M3BP 160 MA	3GBP 164 101-••A	715	84.1	84.7	0.69	10	5.1	53	2.1	2.6	
5.5	M3BP 160 M	3GBP 164 102-••A	710	84.7	85.6	0.70	13.4	5.5	74	2.4	2.6	
7.5	M3BP 160 L	3GBP 164 103-••A	715	86.3	87.3	0.70	18.1	5.4	100	2.4	2.7	
11	M3BP 180 L	3GBP 184 101-••A	720	89.6	90.3	0.76	23.5	5.7	146	2.1	2.5	
15	M3BP 200 MLA	3GBP 204 001-••A	740	91.1	91.6	0.82	29	7.5	196	3.0	3.2	
18.5	M3BP 225 SMA	3GBP 224 001-••A	730	91.1	91.6	0.79	37	6.8	242	2.8	3.1	
22	M3BP 225 SMB	3GBP 224 002-••A	730	91.5	92.2	0.77	45	6.4	287	2.4	2.6	
30	M3BP 250 SMA	3GBP 254 001-••A	735	92.8	93.1	0.79	59	7.3	389	2.2	2.6	
37	M3BP 280 SMA	3GBP 284 210-••G	741	93.4	93.3	0.78	74	7.3	477	1.7	3.0	
45	M3BP 280 SMB	3GBP 284 220-••G	741	94.1	93.8	0.78	90	7.6	580	1.8	3.1	
55	M3BP 315 SMA	3GBP 314 210-••G	742	94.1	94.0	0.81	104	7.1	708	1.6	2.7	
75	M3BP 315 SMB	3GBP 314 220-••G	741	94.5	94.4	0.82	141	7.1	968	1.7	2.7	
90	M3BP 315 SMC	3GBP 314 230-••G	741	94.8	94.7	0.82	167	7.4	1161	1.8	2.7	
110	M3BP 315 MLA	3GBP 314 410-••G	740	95.0	95.0	0.83	203	7.3	1420	1.8	2.7	
132	M3BP 355 SMA	3GBP 354 210-••G	744	95.7	95.6	0.80	250	7.5	1694	1.5	2.6	
160	M3BP 355 SMB	3GBP 354 220-••G	744	95.7	95.6	0.80	305	7.6	2054	1.6	2.6	
200	M3BP 355 SMC	3GBP 354 230-••G	743	95.7	95.6	0.80	378	7.4	2570	1.6	2.6	
250 ²⁾	M3BP 355 MLB	3GBP 354 420-••G	743	95.9	95.8	0.80	476	7.5	3213	1.6	2.7	
315 ¹⁾	M3BP 355 LKB	3GBP 354 820-••G	742	95.9	95.9	0.80	594	7.9	4054	1.7	2.7	
315 ²⁾	M3BP 400 LA	3GBP 404 510-••G	744	96.4	96.3	0.81	582	7.0	4043	1.2	2.6	
315 ²⁾³⁾	M3BP 400 LKA	3GBP 404 810-••G	744	96.4	96.3	0.81	582	7.0	4043	1.2	2.6	
355 ²⁾	M3BP 400 LB	3GBP 404 520-••G	743	96.5	96.5	0.83	640	6.8	4563	1.2	2.5	
355 ²⁾³⁾	M3BP 400 LKB	3GBP 404 820-••G	743	96.5	96.5	0.83	640	6.8	4563	1.2	2.5	
400 ²⁾	M3BP 400 LC	3GBP 404 530-••G	744	96.6	96.5	0.82	735	7.4	5134	1.3	2.7	
400 ²⁾³⁾	M3BP 400 LKC	3GBP 404 830-••G	744	96.6	96.5	0.82	735	7.4	5134	1.3	2.7	
450 ²⁾	M3BP 450 LA	3GBP 454 510-••G	744	96.3	96.3	0.82	820	6.2	5776	1.0	2.2	
500 ²⁾	M3BP 450 LB	3GBP 454 520-••G	744	96.4	96.4	0.82	910	6.3	6418	1.0	2.3	
560 ²⁾	M3BP 450 LC	3GBP 454 530-••G	745	96.6	96.5	0.82	1015	6.5	7178	1.1	2.3	
630 ¹⁾	M3BP 450 LD	3GBP 454 540-••G	745	96.7	96.6	0.82	1145	6.9	8075	1.2	2.5	
750 r/min = 8-poles			400 V 50 Hz				High-output design					
8.5 ¹⁾	M3BP 160 LB	3GBP 164 104-••A	700	85.1	85.7	0.70	21	5.3	114	2.3	2.6	
15 ¹⁾	M3BP 180 LB	3GBP 184 102-••A	720	88.7	89.6	0.76	32.5	6.0	199	2.4	2.6	
18.5	M3BP 200 MLB	3GBP 204 002-••A	735	91.4	91.8	0.81	36	7.3	241	2.6	3.1	
30 ¹⁾	M3BP 225 SMC	3GBP 224 003-••A	735	90.5	91.3	0.79	64	6.7	391	2.5	3.0	
37	M3BP 250 SMB	3GBP 254 002-••A	735	93.0	93.3	0.81	74	7.4	479	2.0	2.6	
55	M3BP 280 SMC	3GBP 284 230-••G	741	94.4	94.3	0.80	105	7.9	709	1.9	3.1	
132	M3BP 315 LKA	3GBP 314 810-••G	740	95.1	95.2	0.83	243	7.3	1703	1.8	2.6	
150 ²⁾	M3BP 315 LKB	3GBP 314 820-••G	741	95.3	95.3	0.83	275	7.7	1933	1.9	2.7	
160 ²⁾	M3BP 315 LKC	3GBP 314 830-••G	740	95.2	95.2	0.83	292	7.7	2065	1.9	2.8	

¹⁾ Temperature rise class F.

²⁾ Temperature rise class F by 380 V 50 Hz.

³⁾ Size with alternative dimensions

The two bullets in the product code indicate choice of mounting arrangement, voltage and frequency (see ordering information page).

LV Process performance cast iron motors

Technical data for totally enclosed squirrel cage three phase motors

IP 55 – IC 411 – Insulation class F, temperature rise class B

Output kW	Motor type	Speed r/min	Efficiency %	Power factor cos φ	Current I _N A	Speed r/min	Efficiency %	Power factor cos φ	Current I _N A	Moment of inertia J=1/4 GD ² kgm ²	Weight kg	Sound pressure level L _p dB(A)
750 r/min = 8-poles			750 r/min = 8-poles			380 V 50 Hz			415 V 50 Hz			
4	M3BP 160 MA	710	83.5	0.71	10.2	720	84.1	0.66	9.9	0.072	100	59
5.5	M3BP 160 M	705	84.0	0.72	13.8	715	85.0	0.68	13.3	0.091	113	59
7.5	M3BP 160 L	710	85.7	0.72	18.6	715	86.6	0.68	17.8	0.131	126	59
11	M3BP 180 L	715	89.0	0.77	24.5	720	89.8	0.75	23	0.224	177	59
15	M3BP 200 MLA	735	91.0	0.83	30	740	91.2	0.79	29	0.45	250	60
18.5	M3BP 225 SMA	730	91.0	0.79	39	735	91.3	0.76	36	0.61	305	63
22	M3BP 225 SMB	730	91.0	0.81	47	735	91.7	0.76	44	0.68	320	63
30	M3BP 250 SMA	735	92.6	0.81	61	740	92.7	0.77	58	1.25	415	63
37	M3BP 280 SMA	740	93.4	0.80	75	742	93.4	0.76	73	1.85	605	65
45	M3BP 280 SMB	740	93.9	0.80	91	742	94.1	0.75	89	2.2	645	65
55	M3BP 315 SMA	741	93.9	0.83	108	743	94.1	0.79	103	3.2	830	62
75	M3BP 315 SMB	740	94.3	0.83	147	742	94.5	0.81	137	4.1	930	62
90	M3BP 315 SMC	740	94.6	0.84	173	742	94.8	0.81	164	4.9	1000	64
110	M3BP 315 MLA	739	94.9	0.84	210	741	95.0	0.81	198	5.8	1150	72
132	M3BP 355 SMA	743	95.6	0.82	257	745	95.7	0.78	247	7.9	1520	69
160	M3BP 355 SMB	743	95.6	0.82	310	745	95.7	0.78	300	9.7	1680	69
200	M3BP 355 SMC	742	95.6	0.81	398	744	95.7	0.78	373	11.3	1820	69
250	²⁾ M3BP 355 MLB	741	95.6	0.81	490	743	95.9	0.78	468	13.5	2180	72
315	¹⁾ M3BP 355 LKB	741	95.8	0.82	610	743	95.9	0.78	590	16.5	2600	75
315	²⁾ M3BP 400 LA	743	96.3	0.82	608	744	96.4	0.79	580	17	2900	71
315	²⁾³⁾ M3BP 400 LKA	743	96.3	0.82	608	744	96.4	0.79	580	17	2900	71
355	²⁾ M3BP 400 LB	742	96.4	0.84	665	744	96.6	0.82	624	21	3200	71
355	²⁾³⁾ M3BP 400 LKB	742	96.4	0.84	665	744	96.6	0.82	624	21	3200	71
400	²⁾ M3BP 400 LC	743	96.5	0.83	765	744	96.6	0.80	720	24	3400	71
400	²⁾³⁾ M3BP 400 LKC	743	96.5	0.83	765	744	96.6	0.80	720	24	3400	71
450	²⁾ M3BP 450 LA	743	96.2	0.83	855	745	96.4	0.81	800	26	3750	82
500	²⁾ M3BP 450 LB	744	96.3	0.83	950	745	96.5	0.81	890	29	4000	82
560	²⁾ M3BP 450 LC	744	96.5	0.83	1060	745	96.6	0.81	995	35	4350	82
630	¹⁾ M3BP 450 LD	744	96.6	0.83	1190	745	96.7	0.81	1120	41	4800	82
750 r/min = 8-poles			750 r/min = 8-poles			380 V 50 Hz			415 V 50 Hz			
8.5	¹⁾ M3BP 160 LB	695	84.6	0.73	21.5	705	85.3	0.68	20.5	0.131	128	62
15	¹⁾ M3BP 180 LB	715	88.1	0.78	33.5	720	89.1	0.74	32	0.24	185	62
18.5	M3BP 200 MLB	735	91.2	0.83	37	735	91.6	0.79	35	0.54	275	60
30	¹⁾ M3BP 225 SMC	730	90.4	0.80	65	735	90.9	0.77	63	0.8	345	63
37	M3BP 250 SMB	735	92.5	0.82	77	735	92.8	0.81	73	1.52	460	63
55	M3BP 280 SMC	739	94.2	0.82	108	742	94.4	0.78	104	2.85	725	65
132	M3BP 315 LKA	739	95.0	0.84	251	741	95.2	0.82	238	7.3	1410	74
150	²⁾ M3BP 315 LKB	739	95.2	0.84	287	741	95.3	0.82	270	8.3	1520	74
160	²⁾ M3BP 315 LKC	738	95.1	0.84	305	741	95.2	0.82	285	9.2	1600	75

LV Process performance cast iron motors

Technical data for totally enclosed squirrel cage three phase motors, two-speed

IP 55 – IC 411 – Insulation class F, temperature rise class F

Output kW	Motor type	Product code	Speed r/min	Efficiency %	Power factor cos φ	Current		Torque			Moment of inertia J=1/4 GD ² kgm ²	Weight kg
						I _N A	I _s / I _N	T _N Nm	T _s / T _N	T _{max} / T _N		
3000/1500 r/min = 2/4 poles			400 V 50 Hz			Fan drive, two separate windings						
13/1.9	M3BP 160 M	3GBP 168 352-••A	2940/1470	88.5/79.5	0.92/0.79	23/4.4	7.8/6.4	42/12	2.1/2.1	3.0/2.5	0.054	133
17.5/2.5	M3BP 160 L	3GBP 168 353-••A	2925/1475	89.0/81.0	0.92/0.77	31/5.8	7.1/6.7	57/16	2.0/2.5	2.6/2.9	0.057	140
20/2.8	M3BP 180 M	3GBP 188 357-••A	2930/1465	89.0/77.0	0.90/0.77	36/6.9	6.4/5.8	65/18	2.1/1.9	2.4/2.0	0.094	194
25/3.6	M3BP 180 L	3GBP 188 358-••A	2940/1465	90.0/78.0	0.88/0.78	46/8.6	7.5/7.3	81/24	2.6/1.9	2.9/1.9	0.108	200
30/4.1	M3BP 200 MLA	3GBP 208 210-••A	2945/1480	91.5/85.0	0.89/0.72	54/10	8.0/7.1	97/26	2.2/2.7	2.8/2.8	0.15	250
38/5.5	M3BP 200 MLB	3GBP 208 211-••A	2945/1480	92.5/86.5	0.91/0.74	67/13	7.7/6.8	123/35	2.2/2.6	2.6/2.6	0.19	270
43/6	M3BP 225 SMB	3GBP 228 207-••A	2950/1475	92.5/86.5	0.90/0.78	75/13	7.1/5.8	139/39	2.3/2.7	2.4/2.0	0.26	335
50/7	M3BP 225 SMC	3GBP 228 208-••A	2955/1480	93.0/87.5	0.91/0.78	86/15	7.3/6.1	162/45	2.4/2.9	2.4/2.1	0.29	355
70/10	M3BP 250 SMB	3GBP 258 204-••A	2965/1485	94.0/89.5	0.90/0.76	119/22	9.3/7.1	225/64	2.3/2.5	3.1/2.3	0.57	465
84/12	M3BP 280 SMB	3GBP 288 221-••G	2980/1492	94.6/90.2	0.88/0.74	147/26	8.0/7.3	269/77	2.1/3.1	3.0/2.8	0.9	665
100/15	M3BP 280 SMC	3GBP 288 231-••G	2974/1492	94.5/91.0	0.91/0.75	169/32	6.7/7.3	321/96	1.8/3.2	2.4/2.7	1.15	725
125/18	M3BP 315 SMB	3GBP 318 221-••G	2983/1493	95.0/91.9	0.87/0.73	220/39	7.5/6.3	400/115	2.1/2.8	2.9/2.4	1.4	940
150/22	M3BP 315 SMC	3GBP 318 231-••G	2976/1492	95.2/92.4	0.89/0.74	257/47	5.9/6.2	481/141	1.7/2.8	2.1/2.3	1.7	1025
190/27	M3BP 315 MLA	3GBP 318 411-••G	2981/1492	95.8/93.1	0.89/0.74	322/57	7.8/6.7	609/173	2.5/3.2	2.8/2.5	2.1	1190
220/30	M3BP 355 SMA	3GBP 358 211-••G	2982/1491	95.8/91.6	0.90/0.78	370/61	6.8/6.6	705/192	1.3/2.4	2.8/2.4	3	1600
350/45	M3BP 355 MLA	3GBP 358 411-••G	2982/1493	96.4/93.2	0.88/0.68	600/102	7.3/7.2	1121/288	2.0/2.8	2.6/2.9	4.1	2000
3000/1500 r/min = 2-4 poles			400 V 50 Hz			Fan drive, Dahlander-connection						
10/2	M3BP 160 MA	3GBP 168 301-••A	2910/1465	85.0/83.5	0.89/0.73	19/4.8	5.9/6.1	30/43	1.5/2.4	2.3/2.8	0.039	118
16/3.2	M3BP 160 M	3GBP 168 302-••A	2915/1465	87.5/86.5	0.92/0.76	28.5/7	6.6/6.3	52/21	1.8/2.5	2.4/2.8	0.054	133
19.5/4.5	M3BP 160 L	3GBP 168 303-••A	2930/1465	89.0/88.0	0.89/0.77	36/9.7	7.6/6.4	64/29	2.3/2.5	2.9/2.8	0.057	140
21.5/4.7	M3BP 180 M	3GBP 188 305-••A	2935/1465	90.0/88.0	0.91/0.77	38/10	7.0/5.3	70/28	2.1/2.1	2.6/2.3	0.094	194
26/5.2	M3BP 180 L	3GBP 188 306-••A	2940/1470	90.5/89.5	0.89/0.75	47/11	6.9/5.8	85/34	2.3/2.4	2.6/2.4	0.108	200
32/8	M3BP 200 MLA	3GBP 208 110-••A	2940/1465	90.0/89.5	0.89/0.85	58/16	7.1/6.2	104/52	2.0/2.0	2.5/2.2	0.28	255
39/10	M3BP 200 MLB	3GBP 208 111-••A	2950/1475	91.5/91.0	0.89/0.85	69/19	7.4/6.2	126/65	2.0/2.0	2.6/2.3	0.34	275
42/11	M3BP 200 MLC	3GBP 208 112-••A	2950/1470	92.5/91.0	0.89/0.77	75/23	7.7/5.6	136/71	2.2/2.1	3.0/2.5	0.19	280
45/13	M3BP 225 SMB	3GBP 228 107-••A	2955/1475	93.0/91.5	0.92/0.82	76/25	7.4/5.3	145/84	2.0/2.0	2.6/2.1	0.27	335
55/15	M3BP 225 SMC	3GBP 228 108-••A	2955/1475	93.5/92.5	0.91/0.82	94/29	7.3/5.4	178/97	2.0/2.0	2.6/2.2	0.3	355
75/25	M3BP 250 SMB	3GBP 258 104-••A	2965/1475	94.5/93.0	0.92/0.82	125/48	8.9/5.5	241/162	2.3/2.0	3.1/2.2	0.36	465
90/30	M3BP 280 SMB	3GBP 288 228-••G	2965/1484	93.5/93.6	0.91/0.86	153/54	7.3/5.8	290/193	1.4/1.7	3.0/2.2	1.5	665
105/33	M3BP 280 SMC	3GBP 288 238-••G	2966/1483	93.5/93.9	0.87/0.85	186/60	7.4/5.7	338/212	1.6/1.7	3.1/2.3	1.85	725
125/25	M3BP 315 SMB	3GBP 318 228-••G	2972/1490	94.9/94.5	0.88/0.73	217/53	6.1/5.4	402/160	1.8/2.4	2.3/2.0	1.4	940
175/45	M3BP 315 MLA	3GBP 318 418-••G	2980/1492	95.4/95.4	0.93/0.84	287/81	9.6/8.9	561/288	2.4/2.9	3.6/3.4	3.5	1160
260/65	M3BP 355 SMB	3GBP 358 228-••G	2983/1491	95.9/95.0	0.88/0.70	450/140	7.5/5.5	832/416	1.6/1.9	2.7/2.1	3.4	1680
320/80	M3BP 355 MLA	3GBP 358 418-••G	2983/1492	96.2/95.7	0.90/0.75	540/160	8.0/6.7	1024/512	1.6/2.1	3.0/2.6	4.1	2000
400/100	M3BP 355 LKA	3GBP 358 818-••G	2983/1492	96.5/96.0	0.90/0.75	670/200	8.0/6.4	1280/640	1.7/2.0	3.0/2.5	4.8	2320

Data for other sizes on request.

The two bullets in the product code indicate choice of mounting arrangement, voltage and frequency (see ordering information page).

LV Process performance cast iron motors

Technical data for totally enclosed squirrel cage three phase motors, two-speed

IP 55 – IC 411 – Insulation class F, temperature rise class F

Output kW	Motor type	Product code	Speed r/min	Efficiency %	Power factor cos φ	Current		Torque			Moment of inertia J=1/4 GD ² kgm ²	Weight kg
						I _N A	I _s / I _N	T _N Nm	T _s / T _N	T _{max} / T _N		
1500/1000 r/min = 4/6 poles 400 V 50 Hz Fan drive, two separate windings												
10.5/3.5	M3BP 160 M	3GBP 168 354-••A	1460/965	87.0/75.5	0.84/0.78	21/8.6	6.4/4.1	69/35	2.0/1.3	2.5/1.7	0.089	127
14.5/4.5	M3BP 160 L	3GBP 168 355-••A	1460/970	88.5/77.0	0.85/0.76	28/11	6.9/4.6	95/44	2.2/1.5	2.6/1.9	0.119	148
16/5	M3BP 180 M	3GBP 188 359-••A	1470/980	89.0/78.0	0.83/0.73	31/12.5	6.3/4.6	104/49	1.9/1.5	2.5/2.0	0.176	194
20/6.5	M3BP 180 L	3GBP 188 360-••A	1470/980	90.0/79.5	0.83/0.74	39/16	7.2/5.0	130/63	2.4/1.8	2.7/2.0	0.224	207
23/7.2	M3BP 200 MLA	3GBP 208 213-••A	1475/985	89.5/84.0	0.88/0.87	43/15	7.7/7.8	149/70	1.6/1.9	2.8/2.9	0.44	250
30/9	M3BP 200 MLB	3GBP 208 214-••A	1470/985	90.0/83.5	0.90/0.89	54/18	7.7/6.3	195/87	1.6/1.2	2.7/2.1	0.53	275
34/11	M3BP 225 SMB	3GBP 228 209-••A	1470/985	91.0/85.0	0.91/0.89	60/21	7.7/6.7	221/107	1.5/1.3	2.7/2.3	0.67	320
42/14	M3BP 225 SMC	3GBP 228 210-••A	1475/985	91.5/89.0	0.89/0.89	75/27	8.4/6.8	272/136	1.7/1.4	3.0/2.3	0.78	345
63/18.5	M3BP 250 SMB	3GBP 258 205-••A	1475/985	93.5/87.0	0.89/0.79	110/40	7.5/7.3	408/179	2.4/3.0	2.7/2.6	0.89	465
85/27	M3BP 280 SMB	3GBP 288 224-••G	1487/992	94.3/90.4	0.82/0.73	160/59	7.5/7.3	546/260	2.7/3.2	3.1/3.1	1.5	665
100/30	M3BP 280 SMC	3GBP 288 234-••G	1486/991	94.7/90.6	0.85/0.77	180/62	7.3/6.6	643/289	2.5/2.8	2.9/2.6	1.85	725
120/36	M3BP 315 SMB	3GBP 318 224-••G	1487/991	95.1/91.4	0.86/0.79	212/72	6.2/6.0	771/347	1.8/2.3	2.3/2.5	2.6	960
145/43	M3BP 315 SMC	3GBP 318 234-••G	1487/991	95.3/92.4	0.86/0.79	256/86	6.3/6.2	931/414	1.8/2.5	2.3/2.5	2.9	1000
180/54	M3BP 315 MLA	3GBP 318 414-••G	1484/990	95.5/92.0	0.86/0.79	321/109	6.1/6.0	1158/521	1.9/2.5	2.5/2.5	3.6	1160
210/63	M3BP 315 LKA	3GBP 318 814-••G	1486/990	95.2/91.3	0.86/0.79	372/127	6.4/6.2	1349/608	2.0/2.7	2.6/2.6	4.4	1410
220/65	M3BP 355 SMA	3GBP 358 214-••G	1489/991	95.9/93.5	0.85/0.77	390/131	6.3/6.3	1411/626	1.6/2.4	2.5/2.3	5.9	1610
250/75	M3BP 315 LKB	3GBP 318 824-••G	1487/992	95.6/92.4	0.85/0.77	445/155	7.7/7.2	1605/722	2.5/3.3	3.1/3.0	5	1520
300/90	M3BP 355 SMC	3GBP 358 234-••G	1488/991	96.0/94.2	0.86/0.76	525/183	6.3/6.9	1925/867	1.7/2.8	2.4/2.5	7.2	1820
390/110	M3BP 355 MLB	3GBP 358 424-••G	1490/992	96.4/94.5	0.84/0.77	700/221	7.4/7.1	2499/1059	2.2/2.9	2.9/2.5	8.4	2140
1500/750 r/min = 4/8 poles 400 V 50 Hz Fan drive, two separate windings												
9/1.3	M3BP 160 M	3GBP 168 356-••A	1460/735	87.0/60.0	0.84/0.53	18/5.9	6.6/4.0	59/17	2.0/2.2	2.5/2.7	0.089	127
13/1.8	M3BP 160 L	3GBP 168 357-••A	1455/735	88.0/64.0	0.85/0.53	26/8.2	6.0/4.1	89/26	1.9/2.2	2.3/2.6	0.119	148
16/2.3	M3BP 180 M	3GBP 188 361-••A	1475/740	88.5/64.0	0.82/0.53	32/9.7	6.8/4.1	104/30	2.2/2.2	2.7/2.6	0.176	194
19/2.7	M3BP 180 L	3GBP 188 362-••A	1475/740	89.5/68.0	0.83/0.54	37/10.5	7.5/7.2	123/35	2.6/2.6	2.9/2.6	0.224	207
26/3.3	M3BP 200 MLA	3GBP 208 216-••A	1475/740	91.0/73.0	0.85/0.59	49/11	6.9/4.6	168/46	2.1/2.2	2.5/2.3	0.28	255
30/3.8	M3BP 200 MLB	3GBP 208 217-••A	1470/740	91.5/75.5	0.86/0.59	55/12.5	6.7/4.6	195/49	2.1/2.2	2.4/2.2	0.34	275
38/5.2	M3BP 225 SMB	3GBP 228 211-••A	1480/740	91.5/80.5	0.84/0.63	72/15	7.3/5.2	245/67	2.1/2.3	2.6/2.3	0.41	330
46/7	M3BP 225 SMC	3GBP 228 212-••A	1480/740	92.5/82.0	0.86/0.66	85/19	7.7/4.9	297/90	2.3/2.1	2.7/2.1	0.49	355
63/10	M3BP 250 SMB	3GBP 258 206-••A	1475/740	93.5/83.0	0.89/0.65	110/27	7.5/6.0	408/129	2.4/3.0	2.7/2.7	0.89	465
85/12	M3BP 280 SMB	3GBP 288 222-••G	1487/744	94.3/85.5	0.82/0.60	160/34	7.5/5.3	546/154	2.7/3.5	3.1/2.4	1.5	665
100/15	M3BP 280 SMC	3GBP 288 232-••G	1486/744	94.7/86.5	0.85/0.62	180/40	7.3/5.4	643/193	2.5/3.4	2.9/2.3	1.85	725
120/16	M3BP 315 SMB	3GBP 318 222-••G	1487/744	95.1/87.8	0.86/0.67	212/41	6.2/4.5	771/205	1.8/2.1	2.3/2.1	2.6	960
145/19	M3BP 315 SMC	3GBP 318 232-••G	1487/744	95.3/88.9	0.86/0.64	256/48	6.3/4.8	931/244	1.8/2.3	2.3/2.1	2.9	1000
180/23	M3BP 315 MLA	3GBP 318 412-••G	1484/743	95.5/89.2	0.86/0.57	321/58	6.1/4.9	1158/296	1.9/2.5	2.5/2.2	3.6	1160
210/27	M3BP 315 LKA	3GBP 318 812-••G	1486/743	95.2/88.8	0.86/0.63	372/70	6.4/4.9	1349/347	2.0/2.6	2.6/2.2	4.4	1410
220/28	M3BP 355 SMA	3GBP 358 212-••G	1489/744	95.9/91.4	0.85/0.63	390/70	6.3/5.5	1411/359	1.6/2.0	2.5/2.2	5.9	1610
250/32	M3BP 315 LKB	3GBP 318 822-••G	1487/744	95.6/89.8	0.85/0.63	445/81	7.7/5.0	1605/411	2.5/2.6	3.1/2.2	5	1520
300/38	M3BP 355 SMC	3GBP 358 232-••G	1488/745	96.0/92.0	0.86/0.62	525/96	6.3/6.1	1925/487	1.7/2.3	2.4/2.3	7.2	1820
390/50	M3BP 355 MLB	3GBP 358 422-••G	1490/744	96.4/92.6	0.84/0.64	700/123	7.4/5.9	2499/642	2.2/2.2	2.9/2.1	8.4	2140

Data for other sizes on request.

The two bullets in the product code indicate choice of mounting arrangement, voltage and frequency (see ordering information page).

LV Process performance cast iron motors

Technical data for totally enclosed squirrel cage three phase motors, two-speed

IP 55 – IC 411 – Insulation class F, temperature rise class F

Output kW	Motor type	Product code	Speed r/min	Efficiency %	Power factor cos φ	Current		Torque			Moment of inertia J=1/4 GD ² kgm ²	Weight kg
						I _N A	I _s / I _N	T _N Nm	T _s / T _N	T _{max} / T _N		
1500/750 r/min = 4-8 poles			400 V 50 Hz			Fan drive, Dahlander-connection						
10.5/2.2	M3BP 160 M	3GBP 168 304-••A	1460/735	87.5/79.0	0.84/0.54	21/7.4	6.9/3.7	69/29	2.2/1.5	2.7/2.3	0.089	127
15.5/2.7	M3BP 160 L	3GBP 168 305-••A	1460/735	88.5/79.5	0.85/0.51	30/9.5	6.9/3.9	101/35	2.2/1.7	2.6/2.6	0.119	148
17/3.4	M3BP 180 M	3GBP 188 307-••A	1470/730	88.5/78.0	0.85/0.56	33/11	5.8/4.3	111/44	1.7/1.2	2.3/1.9	0.176	194
22/4.4	M3BP 180 L	3GBP 188 308-••A	1475/735	89.5/79.0	0.83/0.53	43/15	6.7/3.9	143/57	2.0/1.7	2.6/2.3	0.224	207
29/6.5	M3BP 200 MLA	3GBP 208 116-••A	1470/730	90.5/86.0	0.86/0.64	54/17	6.9/4.2	188/81	2.2/1.9	2.4/1.9	0.28	255
33/8	M3BP 200 MLB	3GBP 208 117-••A	1475/730	91.5/86.5	0.86/0.64	61/21	7.8/4.2	214/105	2.6/1.9	2.6/1.8	0.34	275
42/10	M3BP 225 SMB	3GBP 228 111-••A	1480/740	92.0/89.5	0.86/0.64	85/27	7.8/5.0	271/129	2.5/2.2	3.0/2.3	0.49	335
50/11	M3BP 225 SMC	3GBP 228 112-••A	1465/735	92.5/89.5	0.87/0.65	91/28	7.3/4.7	324/143	2.3/2.0	2.5/2.0	0.49	355
60/15	M3BP 250 SMB	3GBP 258 106-••A	1475/735	93.0/90.0	0.86/0.70	104/34	7.9/4.7	388/195	2.6/2.1	2.7/2.0	0.89	465
80/18.5	M3BP 280 SMB	3GBP 288 229-••G	1486/743	94.1/91.5	0.85/0.62	145/47	7.6/5.2	514/238	2.6/2.5	3.1/2.3	1.5	665
90/20	M3BP 280 SMC	3GBP 288 239-••G	1486/743	94.4/91.9	0.87/0.62	160/50	7.8/5.2	578/257	2.7/2.5	3.1/2.3	1.85	725
125/28	M3BP 315 SMB	3GBP 318 229-••G	1488/744	95.1/92.6	0.84/0.60	226/73	7.0/4.3	802/359	2.3/2.1	2.9/2.3	2.6	960
160/37	M3BP 315 MLA	3GBP 318 419-••G	1486/742	95.0/92.8	0.86/0.62	283/93	6.8/4.0	1028/476	2.4/2.0	2.8/2.1	3.5	1160
200/50	M3BP 315 LKA	3GBP 318 819-••G	1487/742	94.9/92.9	0.86/0.62	354/125	7.4/3.9	1284/643	2.8/2.0	3.1/2.0	4.4	1410
220/50	M3BP 355 SMA	3GBP 358 219-••G	1489/744	95.7/94.3	0.85/0.61	395/126	7.2/4.6	1411/642	2.1/1.6	2.9/2.0	5.9	1610
260/65	M3BP 315 LKC	3GBP 318 839-••G	1489/743	95.3/93.5	0.85/0.60	470/165	8.5/4.3	1667/835	3.5/2.3	3.6/2.3	5.5	1600
300/70	M3BP 355 SMC	3GBP 358 239-••G	1490/744	96.0/94.6	0.85/0.60	536/177	8.3/5.0	1923/898	2.6/1.8	3.3/2.1	7.2	1820
1000/750 r/min = 6/8 poles			400 V 50 Hz			Fan drive, two separate windings						
17/7.5	M3BP 200 MLB	3GBP 208 221-••A	985/740	88/81.5	0.85/0.77	33/17	7.1/6.4	165/97	2.2/2.2	2.5/2.5	0.42	260
20/9	M3BP 200 MLC	3GBP 208 222-••A	985/740	88.5/82.5	0.84/0.74	39/21	7.6/7.0	194/116	2.4/2.6	2.7/2.9	0.48	275
26/12	M3BP 225 SMB	3GBP 228 215-••A	985/740	89.5/84.5	0.85/0.76	49/27	7.4/7.1	252/155	2.2/2.4	2.5/2.7	0.63	320
32/14	M3BP 225 SMC	3GBP 228 216-••A	985/740	90.5/85.5	0.83/0.76	62/31	7.0/7.2	310/180	2.4/2.5	2.4/2.5	0.74	345
43/15	M3BP 250 SMB	3GBP 258 208-••A	990/745	91/86	0.84/0.75	81/34	7.3/7.4	415/198	2.2/2.7	2.5/2.8	1.41	460
53/20	M3BP 280 SMB	3GBP 288 226-••G	990/745	93.4/88	0.84/0.72	99/46	6.4/7.2	511/256	2.2/3.0	2.4/2.6	2.2	645
70/26	M3BP 280 SMC	3GBP 288 236-••G	992/745	94.1/90	0.81/0.73	132/58	7.9/7.3	674/333	2.7/3.2	2.8/2.6	2.85	725
84/36	M3BP 315 SMB	3GBP 318 226-••G	993/745	94.3/90.8	0.83/0.74	156/78	7.2/7.2	808/461	1.9/2.7	2.4/3.0	4.1	930
103/44	M3BP 315 SMC	3GBP 318 236-••G	993/745	94.5/91.5	0.81/0.75	195/94	7.9/7.0	991/564	2.2/2.7	2.6/2.8	4.9	1000
123/52	M3BP 315 MLA	3GBP 318 416-••G	993/745	94.8/92	0.82/0.75	230/109	7.6/7.3	1183/667	2.1/2.8	2.5/2.8	5.8	1150
140/60	M3BP 315 LKA	3GBP 318 816-••G	993/745	94.7/92.5	0.83/0.74	260/127	7.6/7.9	1346/769	2.1/3.1	2.4/3.0	7.3	1410
140/60	M3BP 355 SMA	3GBP 358 216-••G	994/745	95.3/93	0.81/0.75	263/125	7.3/7.4	1345/769	2.0/2.6	2.6/2.5	7.9	1520
158/67	M3BP 315 LKB	3GBP 318 826-••G	993/745	94.9/92.7	0.84/0.74	288/142	7.6/8.0	1519/859	2.1/3.2	2.4/3.0	8.3	1520
180/76	M3BP 315 LKC	3GBP 318 836-••G	993/745	95.1/92.9	0.83/0.73	330/163	8.1/8.4	1731/974	2.3/3.5	2.5/3.2	9.2	1600
180/76	M3BP 355 SMB	3GBP 358 226-••G	994/745	95.5/93.3	0.81/0.75	317/157	7.5/7.3	1729/974	2.2/2.7	2.7/2.5	9.7	1680
210/88	M3BP 355 SMC	3GBP 358 236-••G	994/745	95.6/93.5	0.82/0.76	390/178	7.3/7.0	2017/1128	2.2/2.6	2.6/2.4	11.3	1820
250/105	M3BP 355 MLB	3GBP 358 426-••G	994/744	95.6/93.4	0.81/0.75	463/218	7.3/6.6	2402/1348	2.3/2.6	2.7/2.4	13.5	2180
315/132	M3BP 355 LKB	3GBP 358 826-••G	993/745	95.8/93.7	0.81/0.71	583/290	6.9/8.3	3029/1692	2.2/3.6	2.5/3.0	16.5	2600
355/150	M3BP 400 LB	3GBP 408 526-••G	995/745	96.2/94.7	0.80/0.76	670/300	7.0/6.8	3407/1923	1.6/1.9	2.6/2.2	20.5	3150
355/150	M3BP 400 LKB	3GBP 408 826-••G	995/745	96.2/94.7	0.80/0.76	670/300	7.0/6.8	3407/1923	1.6/1.9	2.6/2.2	20.5	3150
400/170	M3BP 400 LD	3GBP 408 546-••G	995/746	96.3/94.9	0.82/0.75	740/350	6.8/7.4	3839/2176	1.5/2.2	2.5/2.4	24	3400
400/170	M3BP 400 LKD	3GBP 408 846-••G	995/746	96.3/94.9	0.82/0.75	740/350	6.8/7.4	3839/2176	1.5/2.2	2.5/2.4	24	3400

Data for other sizes on request.

The two bullets in the product code indicate choice of mounting arrangement, voltage and frequency (see ordering information page).

LV Process performance cast iron motors

Technical data for totally enclosed squirrel cage three phase motors, two-speed

IP 55 – IC 411 – Insulation class F, temperature rise class F

Output kW	Motor type	Product code	Speed r/min	Efficiency %	Power factor cos φ	Current		Torque			Moment of inertia J=1/4 GD ² kgm ²	Weight kg
						I _N A	I _s / I _N	T _N Nm	T _s / T _N	T _{max} / T _N		
3000/1500 r/min = 2/4 poles			400 V 50 Hz			Constant torque, two separate windings						
12/6	M3BP 160 M	3GBP 168 359-••A	2835/1460	87.5/84.5	0.92/0.80	22/13	7.7/6.0	39/39	2.1/2.3	2.8/2.4	0.054	133
15/7.5	M3BP 160 L	3GBP 168 360-••A	2940/1460	88.5/84.5	0.93/0.78	27/16.5	7.9/6.0	49/49	2.2/2.4	2.9/2.4	0.057	140
18/9	M3BP 180 L	3GBP 188 352-••A	2945/1460	89.0/84.0	0.90/0.77	32/20	7.7/5.2	58/59	2.5/2.3	2.8/2.1	0.108	200
23/12	M3BP 200 MLA	3GBP 208 201-••A	2960/1475	90.0/89.0	0.89/0.85	42/23	7.8/7.4	74/77	1.7/2.2	2.8/2.5	0.28	255
30/16	M3BP 200 MLB	3GBP 208 202-••A	2960/1475	91.0/90.0	0.90/0.87	53/30	8.2/7.3	97/104	1.8/2.2	2.9/2.5	0.34	275
36/18	M3BP 225 SMB	3GBP 228 201-••A	2960/1480	91.5/91.5	0.91/0.76	63/38	8.0/7.2	116/116	2.5/3.8	2.7/2.5	0.26	335
40/20	M3BP 225 SMC	3GBP 228 202-••A	2960/1475	92.0/91.5	0.91/0.79	69/41	8.5/6.5	129/129	2.8/3.3	2.8/2.2	0.29	355
50/25	M3BP 250 SMB	3GAA 258 201-••A	2965/1485	93.0/93.0	0.91/0.76	86/52	8.9/8.5	161/161	2.1/3.5	2.9/2.9	0.57	465
65/33	M3BP 280 SMB	3GBP 289 221-••G	2979/1488	93.5/93.2	0.89/0.77	112/67	7.5/6.7	208/212	1.8/2.8	2.7/2.5	0.9	665
82/41	M3BP 280 SMC	3GBP 289 231-••G	2979/1488	94.1/93.9	0.90/0.78	141/81	7.8/7.2	263/263	2.1/3.1	2.7/2.6	1.15	725
100/50	M3BP 315 SMB	3GBP 319 221-••G	2986/1488	94.0/94.2	0.85/0.76	183/101	8.6/5.8	320/321	2.3/2.5	3.3/2.3	1.4	940
125/63	M3BP 315 SMC	3GBP 319 231-••G	2980/1490	94.6/94.1	0.89/0.75	216/128	6.7/6.6	401/404	1.8/3.0	2.4/2.5	1.7	1025
155/78	M3BP 315 MLA	3GBP 319 411-••G	2985/1489	95.2/94.5	0.89/0.76	267/157	8.9/6.3	496/500	2.6/3.0	3.2/2.5	2.1	1190
180/90	M3BP 355 SMA	3GBP 359 211-••G	2985/1490	95.3/94.9	0.89/0.78	308/175	7.7/7.0	576/577	1.4/2.5	3.2/2.9	3	1600
300/150	M3BP 355 MLA	3GBP 359 411-••G	2985/1491	96.0/95.5	0.88/0.69	512/328		960/961	2.0/3.0	2.9/2.9	4.1	2000
3000/1500 r/min = 2-4 poles			400 V 50 Hz			Constant torque, Dahlander-connection						
9/6.5	M3BP 160 MA	3GBP 168 306-••A	2885/1440	83.0/82.0	0.92/0.74	17.1/15.6	4.6/4.3	40/43	1.3/1.7	1.9/1.9	0.039	118
12.5/9	M3BP 160 M	3GBP 168 307-••A	2890/1440	85.5/85.5	0.93/0.80	22.5/19	5.2/4.6	41/60	1.4/1.8	1.9/1.9	0.054	133
15/10.5	M3BP 160 L	3GBP 168 308-••A	2900/1445	87.0/86.0	0.93/0.77	27/23	5.8/4.9	49/69	1.6/2.1	2.1/2.1	0.057	140
18/12	M3BP 180 M	3GBP 188 301-••A	2940/1455	89.0/89.0	0.88/0.79	33/25	6.8/5.3	59/79	2.1/2.4	2.6/2.2	0.094	194
24/17	M3BP 180 L	3GBP 188 302-••A	2945/1455	90.0/90.0	0.89/0.80	43/34	7.4/5.2	78/111	2.4/2.4	2.8/2.1	0.108	200
32/24	M3BP 200 MLA	3GBP 208 101-••A	2940/1470	89.0/90.5	0.89/0.86	58/45	6.8/5.9	104/156	1.8/2.1	2.4/2.1	0.28	255
39/29	M3BP 200 MLB	3GBP 208 102-••A	2950/1470	90.5/91.0	0.84/0.86	75/53	6.8/7.0	126/188	1.7/2.2	2.6/2.4	0.34	275
42/32	M3BP 225 SMB	3GBP 228 101-••A	2955/1475	92.5/93.0	0.92/0.88	71/57	7.1/6.5	136/207	1.5/1.9	2.5/2.3	0.49	330
50/40	M3BP 225 SMC	3GBP 228 102-••A	2960/1475	92.5/93.0	0.84/0.87	94/71	7.4/7.1	161/259	1.8/2.0	2.8/2.5	0.49	355
68/50	M3BP 250 SMB	3GBP 258 101-••A	2940/1475	93.0/93.5	0.93/0.88	113/87	6.6/6.9	220/324	1.5/2.1	2.4/2.5	0.89	465
90/65	M3BP 280 SMB	3GBP 289 228-••G	2965/1488	93.5/94.8	0.91/0.85	153/117	7.3/8.6	290/417	1.4/2.8	3.0/3.3	1.5	665
105/75	M3BP 280 SMC	3GBP 289 238-••G	2966/1486	93.5/94.9	0.87/0.84	186/136	7.4/8.2	338/482	1.6/2.6	3.1/3.3	1.85	725
125/85	M3BP 315 SMB	3GBP 319 228-••G	2972/1485	94.9/95.0	0.88/0.73	217/178	6.1/5.3	402/547	1.8/2.6	2.3/2.1	1.4	940
175/120	M3BP 315 MLA	3GBP 319 418-••G	2980/1491	95.4/96.0	0.93/0.81	287/223	9.6/9.9	561/769	2.4/3.7	3.6/4.0	3.5	1160
250/160	M3BP 355 SMC	3GBP 359 238-••G	2982/1491	95.9/95.7	0.88/0.63	430/383	7.5/6.4	801/1025	1.6/2.7	2.7/2.6	3.6	1750
310/200	M3BP 355 MLB	3GBP 359 428-••G	2983/1491	96.3/96.2	0.91/0.71	510/425	8.1/7.5	992/1281	1.6/2.6	3.0/3.2	4.3	2080
380/250	M3BP 355 LKB	3GBP 359 828-••G	2982/1490	96.5/96.5	0.91/0.73	630/515	7.9/7.2	1217/1602	1.7/2.5	3.0/3.0	5.2	2460

Data for other sizes on request.

The two bullets in the product code indicate choice of mounting arrangement, voltage and frequency (see ordering information page).

LV Process performance cast iron motors

Technical data for totally enclosed squirrel cage three phase motors, two-speed

IP 55 – IC 411 – Insulation class F, temperature rise class F

Output kW	Motor type	Product code	Speed r/min	Efficiency %	Power factor cos φ	Current		Torque			Moment of inertia J=1/4 GD ² kgm ²	Weight kg
						I _N A	I _s /I _N	T _N Nm	T _s /T _N	T _{max} /T _N		
1500/1000 r/min = 4/6 poles			400 V 50 Hz			Constant torque, two separate windings						
7.5/5.5	M3BP 160 M	3GBP 168 361-••A	1465/965	85.5/80.5	0.83/0.77	15.5/13	7.1/4.7	49/54	2.1/1.8	2.7/1.9	0.089	127
11.5/8.5	M3BP 160 L	3GBP 168 362-••A	1465/965	86.5/82.5	0.84/0.76	23/19.5	7.0/4.9	75/84	2.1/1.8	2.8/2.0	0.119	148
13/8	M3BP 180 M	3GBP 188 353-••A	1475/975	88/82.5	0.82/0.75	26/19	6.5/4.3	84/78	1.9/1.4	2.6/1.8	0.176	194
15/10	M3BP 180 L	3GBP 188 354-••A	1475/975	88.5/84.0	0.83/0.74	30/23	7.1/4.4	97/98	2.3/1.5	2.7/1.9	0.224	207
18/12	M3BP 200 MLA	3GBP 208 204-••A	1475/985	88.5/86.0	0.91/0.86	33/24	7.6/7.8	117/116	2.1/2.6	2.5/2.6	0.42	260
22/14.7	M3BP 200 MLB	3GBP 208 205-••A	1480/985	89.5/86.5	0.89/0.87	40/29	8.2/7.6	142/143	2.4/2.6	2.8/2.5	0.48	275
25/16.7	M3BP 200 MLC	3GBP 208 206-••A	1475/980	89.0/85.5	0.87/0.88	47/32	7.7/6.7	162/162	2.3/2.3	2.6/2.2	0.48	275
32/21	M3BP 225 SMB	3GBP 228 203-••A	1480/985	90.0/89.5	0.88/0.86	58/40	8.6/8.0	206/204	2.3/2.4	2.8/2.7	0.63	320
36/24	M3BP 225 SMC	3GBP 228 204-••A	1480/985	90.5/90.0	0.88/0.87	66/45	8.4/7.4	232/233	2.2/2.2	2.8/2.5	0.74	345
50/32	M3BP 250 SMB	3GBP 258 202-••A	1475/985	92.5/90.5	0.89/0.80	89/65	7.5/7.1	324/310	2.3/3.1	2.6/2.6	0.89	465
65/43	M3BP 280 SMB	3GBP 289 224-••G	1485/988	92.9/91.9	0.86/0.78	117/87	6.6/6.4	418/416	2.0/2.9	2.5/2.4	1.5	665
76/50	M3BP 280 SMC	3GBP 289 234-••G	1487/989	93.7/92.6	0.86/0.78	137/101	7.2/7.4	488/483	2.2/3.3	2.7/2.4	1.85	725
90/60	M3BP 315 SMB	3GBP 319 224-••G	1490/991	94.3/93.6	0.84/0.75	165/125	7.3/6.6	577/578	2.0/2.9	2.8/2.7	2.6	960
110/75	M3BP 315 SMC	3GBP 319 234-••G	1490/992	94.5/93.9	0.84/0.73	200/158	7.3/7.1	705/722	2.0/3.2	2.8/2.8	2.9	1000
140/95	M3BP 315 MLA	3GBP 319 414-••G	1489/990	94.9/93.7	0.85/0.77	250/190	7.2/6.4	898/916	2.1/2.9	2.8/2.5	3.5	1160
170/112	M3BP 315 LKA	3GBP 319 814-••G	1489/992	94.7/93.9	0.85/0.74	305/235	7.1/7.2	1090/1078	2.1/3.5	2.8/3.0	4.4	1410
180/120	M3BP 355 SMA	3GBP 359 214-••G	1491/992	95.4/95.1	0.84/0.74	330/245	6.8/7.5	1153/1155	1.6/2.8	2.7/2.7	5.9	1610
200/132	M3BP 315 LKB	3GBP 319 824-••G	1491/992	95.1/94.1	0.83/0.74	366/277	8.5/7.4	1281/1271	2.6/3.6	3.4/3.1	5	1520
250/167	M3BP 355 SMC	3GBP 359 234-••G	1490/991	95.7/95.2	0.85/0.76	445/335	6.7/6.9	1602/1609	1.6/2.6	2.6/2.4	7.2	1820
330/220	M3BP 355 MLB	3GBP 359 424-••G	1492/992	96.0/95.4	0.83/0.76	605/443	7.8/7.6	2112/2118	2.1/3.0	3.1/2.6	8.4	2140
1500/750 r/min = 4/8 poles			400 V 50 Hz			Constant torque, two separate windings						
5.5/2.7	M3BP 160 M	3GBP 168 363-••A	1465/730	85.0/71.0	0.83/0.57	11.5/9.6	6.8/4.0	36/35	2.1/2.0	2.6/2.3	0.089	127
9/4.5	M3BP 160 L	3GBP 168 364-••A	1465/730	86.5/73.5	0.83/0.56	18/16	7.0/4.1	59/59	2.1/2.1	2.7/2.5	0.119	148
14/7	M3BP 180 L	3GBP 188 356-••A	1475/735	88.0/76.0	0.83/0.56	28/24	7.7/4.2	91/91	2.6/2.3	2.9/2.3	0.225	207
18.5/9.4	M3BP 200 MLA	3GBP 208 207-••A	1475/730	89.5/82.5	0.85/0.65	35/26	7.3/4.3	120/123	2.2/1.9	2.5/1.8	0.28	255
22/11	M3BP 200 MLB	3GBP 208 208-••A	1480/735	90.5/83.0	0.84/0.60	42/32	8.4/4.7	142/143	2.6/2.4	2.9/2.2	0.34	275
28/14	M3BP 225 SMB	3GBP 228 205-••A	1480/735	90.0/85.5	0.85/0.61	53/39	7.7/4.9	181/182	2.1/2.4	2.7/2.2	0.41	330
34/17	M3BP 225 SMC	3GBP 228 206-••A	1480/735	92.0/87.0	0.86/0.66	63/43	7.9/4.8	219/221	2.2/2.2	2.7/2.0	0.49	355
50/25	M3BP 250 SMB	3GBP 258 203-••A	1480/740	92.5/88.0	0.87/0.60	90/68	8.6/6.0	323/323	2.6/3.5	3.0/2.9	0.89	465
60/30	M3BP 280 SMB	3GBP 289 222-••G	1486/741	92.8/89.5	0.86/0.65	110/74	6.8/5.4	386/387	2.0/2.7	2.6/2.3	1.5	665
74/37	M3BP 280 SMC	3GBP 289 232-••G	1487/741	94.0/90.2	0.86/0.64	132/93	7.3/5.7	475/477	2.2/2.9	2.7/2.4	1.85	725
90/45	M3BP 315 SMB	3GBP 319 222-••G	1490/742	94.3/91.0	0.84/0.64	165/112	7.3/5.0	577/579	2.0/2.4	2.8/2.1	2.6	960
110/55	M3BP 315 SMC	3GBP 319 232-••G	1490/742	94.5/91.5	0.84/0.63	200/139	7.3/5.0	705/708	2.0/2.5	2.8/2.1	2.9	1000
140/70	M3BP 315 MLA	3GBP 319 412-••G	1489/742	94.9/92.2	0.85/0.63	250/173	7.0/5.0	898/901	2.0/2.6	2.7/2.2	3.5	1160
180/90	M3BP 355 SMA	3GBP 359 212-••G	1491/743	95.4/93.5	0.84/0.62	330/225	6.8/6.0	1153/1157	1.6/2.4	2.7/2.4	5.9	1610
250/115	M3BP 355 SMC	3GBP 359 232-••G	1490/744	95.7/93.8	0.85/0.60	445/293	6.7/6.4	1602/1476	1.6/2.7	2.6/2.5	7.2	1820
330/145	M3BP 355 MLB	3GBP 359 422-••G	1492/743	96.0/94.1	0.83/0.63	605/355	7.8/6.1	2112/1864	2.1/2.5	3.1/2.3	8.4	2140

Data for other sizes on request.

The two bullets in the product code indicate choice of mounting arrangement, voltage and frequency (see ordering information page).

LV Process performance cast iron motors

Technical data for totally enclosed squirrel cage three phase motors, two-speed

IP 55 – IC 411 – Insulation class F, temperature rise class F

Output kW	Motor type	Product code	Speed r/min	Efficiency %	Power factor cos φ	Current		Torque			Moment of inertia J=1/4 GD ² kgm ²	Weight kg
						I _N A	I _s / I _N	T _N Nm	T _s / T _N	T _{max} / T _N		
1500/750 r/min = 4-8 poles			400 V 50 Hz			Constant torque, Dahlander-connection						
8/4.5	M3BP 160 M	3GBP 168 309-••A	1440/730	84.5/79.5	0.86/0.60	16/13.5	4.5/3.4	53/59	1.3/1.4	1.8/1.9	0.089	127
12/7	M3BP 160 L	3GBP 168 310-••A	1445/730	86.5/81.0	0.87/0.59	23/21	5/0.35	79/92	1.5/1.4	1.9/1.9	0.119	148
16/8	M3BP 180 L	3GBP 188 304-••A	1460/730	88.0/78.5	0.86/0.53	31/28	1.9/3.4	105/104	1.4/1.6	1.9/2.1	0.224	207
22/13	M3BP 200 MLA	3GBP 208 107-••A	1475/735	87.5/86.0	0.81/0.69	45/32	6.5/5.9	142/169	2.0/2.5	2.6/2.7	0.36	245
25/15	M3BP 200 MLB	3GBP 208 108-••A	1475/735	89.0/86.0	0.86/0.67	47/38	7.6/6.0	162/195	2.2/2.6	2.7/2.7	0.42	260
29/17	M3BP 200 MLC	3GBP 208 109-••A	1475/735	90.0/88.0	0.91/0.75	52/38	7.2/6.1	188/221	2.2/2.6	2.4/2.4	0.48	275
35/21	M3BP 225 SMB	3GBP 228 105-••A	1475/735	90.0/89.0	0.90/0.74	63/47	6.7/5.8	227/273	1.7/2.1	2.2/2.3	0.63	320
42/25	M3BP 225 SMC	3GBP 228 106-••A	1475/735	91.0/89.5	0.91/0.75	74/54	6.8/5.9	272/325	1.8/2.1	2.2/2.2	0.74	345
50/30	M3BP 250 SMB	3GBP 258 103-••A	1480/740	92.0/90.5	0.90/0.75	86/70	7.3/6.4	355/426	2.1/2.5	2.5/2.5	1.5	460
65/40	M3BP 280 SMB	3GBP 289 229-••G	1487/743	93.2/92.2	0.88/0.69	116/92	7.8/6.6	417/514	2.0/2.7	2.8/2.7	2.2	645
85/50	M3BP 280 SMC	3GBP 289 239-••G	1487/743	93.9/93.0	0.88/0.68	149/115	8.7/7.2	546/643	2.4/3.0	3.0/2.9	2.85	725
95/65	M3BP 315 SMB	3GBP 319 229-••G	1489/744	94.0/93.4	0.88/0.72	166/140	7.8/6.2	609/834	2.4/2.7	2.8/2.5	4.1	930
115/80	M3BP 315 SMC	3GBP 319 239-••G	1489/743	94.4/93.8	0.89/0.73	198/167	8.0/6.2	738/1028	2.6/2.6	2.8/2.4	4.9	1000
150/95	M3BP 315 MLA	3GBP 319 419-••G	1489/744	94.3/94.2	0.88/0.73	260/201	8.1/6.5	962/1219	2.7/2.9	2.8/2.5	5.8	1150
190/120	M3BP 315 LKA	3GBP 319 819-••G	1489/744	94.6/94.3	0.88/0.73	332/252	8.6/6.8	1219/1540	2.9/3.0	3.0/2.5	7.3	1410
200/125	M3BP 355 SMB	3GBP 359 229-••G	1490/745	95.2/94.9	0.90/0.71	340/270	8.5/6.9	1282/1602	2.4/2.6	2.9/2.6	9.7	1680
290/185	M3BP 355 MLB	3GBP 359 429-••G	1490/744	95.6/95.1	0.90/0.72	490/390	8.5/6.5	1859/2374	2.7/2.5	3.0/2.5	13.5	2180
1000/750 r/min = 6/8 poles			400 V 50 Hz			Constant torque, two separate windings						
16/12	M3BP 200 MLB	3GBP 208 219-••A	985/740	86.5/82.5	0.85/0.73	31/29	7.0/6.3	155/155	2.1/2.4	2.4/2.6	0.42	260
18/13.5	M3BP 200 MLC	3GBP 208 220-••A	985/740	87.5/83.5	0.83/0.72	36/32	7.9/6.6	174/174	2.5/2.6	2.8/2.8	0.48	275
23/17	M3BP 225 SMB	3GBP 228 213-••A	985/740	89.0/85.5	0.84/0.78	46/37	7.9/6.3	222/220	2.3/2.2	2.7/2.3	0.63	320
28/20	M3BP 225 SMC	3GBP 228 214-••A	985/740	89.0/86.5	0.86/0.77	57/43	7.1/6.5	272/259	2.0/2.3	2.4/2.4	0.74	345
37/27	M3BP 250 SMB	3GBP 258 207-••A	990/740	90.0/87.5	0.83/0.75	71/59	7.8/6.7	357/348	2.3/2.5	2.7/2.5	1.41	460
47/35	M3BP 280 SMB	3GBP 289 226-••G	991/744	92.2/90.7	0.83/0.69	89/81	6.5/7.1	453/449	2.1/3.3	2.5/2.5	2.2	645
60/45	M3BP 280 SMC	3GBP 289 236-••G	992/743	93.2/91.7	0.83/0.71	112/100	7.4/7.1	578/578	2.4/3.3	2.7/2.4	2.85	725
75/56	M3BP 315 SMB	3GBP 319 226-••G	993/744	92.8/92.5	0.82/0.74	142/118	7.3/6.7	721/719	1.8/2.6	2.7/2.6	4.1	930
88/66	M3BP 315 SMC	3GBP 319 236-••G	993/744	93.2/93.0	0.83/0.74	165/139	7.3/7.0	846/847	1.8/2.8	2.7/2.7	4.9	1000
106/80	M3BP 315 MLA	3GBP 319 416-••G	993/744	93.6/93.3	0.83/0.73	198/171	7.5/7.5	1019/1026	1.9/3.1	2.7/2.8	5.8	1150
110/83	M3BP 355 SMA	3GBP 359 216-••G	994/746	94.9/93.7	0.82/0.72	204/177	7.3/8.0	1057/1062	1.9/3.0	2.6/2.7	7.9	1520
135/100	M3BP 355 SMB	3GBP 359 226-••G	994/745	95.1/94.0	0.82/0.75	250/204	7.3/7.2	1297/1282	2.0/2.7	2.6/2.4	9.7	1680
155/116	M3BP 355 SMC	3GBP 359 236-••G	994/744	95.3/94.2	0.82/0.75	288/236	7.1/7.1	1489/1489	1.9/2.7	2.5/2.4	11.3	1820
180/135	M3BP 355 MLB	3GBP 359 426-••G	994/744	95.1/94.3	0.81/0.74	340/282	6.8/7.1	1729/1733	2.0/2.9	2.5/2.5	13.5	2180
220/165	M3BP 355 LKB	3GBP 359 826-••G	993/744	95.3/94.4	0.81/0.74	410/340	6.2/6.9	2116/2118	1.8/2.8	2.2/2.4	16.5	2600

Data for other sizes on request.

The two bullets in the product code indicate choice of mounting arrangement, voltage and frequency (see ordering information page).

LV Process performance cast iron motors - Variant codes

Code 1)	Variant	Motor size						
		71- 132	160- 180	200- 250	280- 315	355	400	450
Balancing								
052	Vibration to Grade A (IEC 60034-14)	M	S	S	S	S	S	S
417	Vibration to Grade B (IEC 60034-14)	M	P	P	P	P	P	P
423	Balanced without key	NA	P	P	P	P	P	P
424	Full key balancing.	M	P	P	P	P	P	P
Bearings and lubrication								
036	Transport lock for bearings.	NA	M	M	M	M	P	P
037	Roller bearing at D-end.	NA	M	M	M	M	P	P
039	Cold resistant grease. For bearing temperatures, sizes 71-132 -30...+ 120°C, Sizes 160-250 -40...+ 100°C. sizes 280-450 -55...+ 100°C.	M	M	M	M	M	P	P
040	Heat resistant grease (-25... +150°C.	M	S	S	M	M	P	P
041	Bearings regreasable via grease nipples.	NA	S	S	S	S	S	S
042	Locked drive-end.	S	S	S	S	S	S	S
043	SPM nipples. Frame sizes 112-132 only foot mounted B3.	M	S	S	S	S	S	S
057	2RS bearings at both ends. Grease for bearing temperatures -20 - +110°C.	S	M	M	NA	NA	NA	NA
058	Angular contact ball bearing at D-end, shaft force away from bearing.	NA	M	M	P	P	P	P
059	Angular contact ball bearing at N-end, shaft force towards bearing.	NA	R	R	P	P	P	P
060	Angular contact bearing at D-end, shaft force towards bearing.	NA	NA	NA	P	P	P	P
061	Angular contact bearing at N-end, shaft force away from bearing.	NA	NA	NA	P	P	P	P
107	Pt100 2-wire in bearings.	NA	P	P	M	M	P	P
130	Pt100 3-wire in bearings.	NA	NA	NA	M	M	P	P
194	2Z-bearings greased for life at both ends.	NA	M	M	NA	NA	NA	NA
420	Bearing mounted PTC thermistors.	NA	R	R	P	P	P	P
433	Outlet grease collector (with hand pump).	NA	NA	NA	P	P	P	P
796	Grease nipples JIS B 1575 PT 1/8 Type A. Stainless steel. Head type to be defined when ordering.	NA	M	M	M	M	P	P
797	Stainless steel measuring nipples.	NA	M	M	M	M	P	P
798	Stainless steel grease nipples.	NA	M	M	M	M	P	P
Brakes								
412	Built-on brake. Branch standard designs	NA	R	R	P	P	P	R
142	"Manilla" winding connection (440 VΔ series, 220 VΔ parallel, 60 Hz).	NA	P	P	P	NA	NA	NA
178	Stainless steel/acid proof bolts.	M	M	M	M	M	P	P
204	Jacking bolts for foot mounted motors.	NA	NA	NA	P	M	P	P
209	Non-standard voltage or frequency (special winding).	M	P	P	P	P	P	P
396	Motor designed for ambient temperature -20°C to -40°C, with space heaters (code 450/451 must be added).	NA	P	P	P	P	P	P
397	Motor designed for ambient temperature -40°C to -55°C, with space heaters (code 450/451 must be added).	NA	R	R	P	P	P	P
398	Motor designed for ambient temperature -20°C to -40°C, without heating.	NA	P	P	P	P	P	P
399	Motor designed for ambient temperature -40°C to -55°C, without heating.	NA	R	R	P	P	P	P
419	Textile industry design.	M	M	M	P	P	NA	NA
425	Corrosion protected stator and rotor core. Frame size 71-112 , only rotor as standard.	M	P	P	P	P	P	P
785	Reinforced tropicalisation.	S	P	P	NA	NA	NA	NA

1) Certain variant codes cannot be used simultaneously.

S = Included as standard
M = On modification of a stocked motor,
or on new manufacture,
the number per order may be limited.

P = New manufacture only.
R = On request.
NA = Not applicable

Code 1)	Variant	Motor size						
		71- 132	160- 180	200- 250	280- 315	355	400	450
Cooling system								
044	Unidirectional fan, clockwise seen from D-end. For 2 pole motors only.	NA	NA	NA	P	P	P	P
045	Unidirectional fan, counter clockwise seen from D-end. For 2 pole motors only.	NA	NA	NA	P	P	P	P
068	Metal fan.	M	M	M	M	M	P	P
075	Cooling method IC 418 (without fan). Output on request for sizes 160-250.	R	M	M	R	R	R	R
183	Separate motor cooling (fan axial, N-end).	M	M	M	P	P	P	P
189	Separate motor cooling, IP 44, 400 V, 50 Hz (fan axial, N-end)	NA	M	M	NA	NA	NA	NA
422	Separate motor cooling (fan top or side, N-end).	NA	NA	NA	P	P	P	P
791	Stainless steel fan cover.	NA	R	R	P	P	P	P
793	Fan for reduced noise level (2-p fan).	NA	R	M	NA	NA	NA	NA
794	Fan for reduced noise level (4-p fan).	NA	R	M	NA	NA	NA	NA
Coupling								
035	Assembly of customer supplied coupling-half.	R	R	R	P	P	P	P
Dimension drawing								
141	Binding dimension drawing.	M	M	M	M	M	M	M
Drain holes								
065	Plugged existing drain holes.	NA	M	M	M	M	P	P
076	Draining holes with plugs. Felt plugs.	M	NA	NA	NA	NA	NA	NA
448	Draining holes with metal plugs.	M	NA	NA	P	P	P	P
Earthing bolt								
067	External earthing bolt.	M	S	S	S	S	S	S
Hazardous environments								
See catalogue "Motors for Hazardous Environments", BU/Ex-motors EN", for details.								
Heating elements								
450	Heating element, 100-120 V.	M	M	M	M	M	P	P
451	Heating element, 200-240 V.	M	M	M	M	M	P	P
Insulation system								
014	Winding insulation class H.	P	P	P	P	P	P	P
405	Special winding insulation for frequency converter supply.	NA	P	P	P	P	P	P
406	Winding for supply > 690 <= 1000 V.	NA	P	P	P	P	P	P
Marine Motors								
See catalogue "Marine Motors, BU/Marine EN" for details.								
Mounting arrangements								
008	IM 2101 foot/flange mounted, from IM 1001 (B34 from B3).	M	NA	NA	NA	NA	NA	NA
009	IM 2001 foot/flange mounted, from IM 1001 (B35 from B3).	M	M	M	M	M	P	P
047	IM 3601 flange mounted, IEC flange, from IM 3001 (B14 from B5).	M	R/NA	NA	NA	NA	NA	NA
048	IM 3001 flange mounted, IEC flange, from IM 3601 (B5 from B14).	M	NA	NA	NA	NA	NA	NA
066	Modified for non-standard mounting position (please specify IM xxxx). (must be ordered for all mounting arrangements excluding IM B3 (1001) and B5 (3001).	NA	M	M	M	M	P	P
078	IM 3601 flange mounted, DIN C flange.	M/NA	NA	NA	NA	NA	NA	NA
090	IM 2101 foot/flange mounted, DIN C flange, from IM 1001 (B34 from B3).	M/NA	NA	NA	NA	NA	NA	NA
304	PAD mounting according to BS4999-141	NA	R	R	R	NA	NA	NA
305	Additional lifting lugs for V1, V3, V5, V6, V15 and V36.	NA	M	M	S	M	P	P

1) Certain variant codes cannot be used simultaneously.

S = Included as standard
M = On modification of a stocked motor, or on new manufacture, the number per order may be limited.

P = New manufacture only.
R = On request.
NA = Not applicable

Code 1)	Variant	Motor size						
		71- 132	160- 180	200- 250	280- 315	355	400	450
Painting								
114	Special paint colour, standard grade. RAL-colour no. must be specified.	M	M	M	M	M	P	P
106	Paint thickness ≥ 80 µm	NA	NA	NA	M	M	P	P
109	Paint thickness ≥ 120 µm	NA	NA	NA	P	P	P	P
110	Paint thickness ≥ 160 µm	NA	NA	NA	P	P	P	P
111	Offshore two-pack polyamide cured epoxy paint 160 mm.	NA	NA	NA	P	P	P	P
115	Offshore zink primer painting.	NA	R	R	P	P	P	P
179	Special paint specification.	R	R	R	R	R	R	R
Protection								
005	Protective roof, vertical motor, shaft down.	M	M	M	M	M	P	P
072	Radial seal at D-end.	M	M	M	M	P	P	P
073	Sealed against oil at D-end.	R	M	M	M	M	P	P
158	Degree of protection IP65. Dust proof version.	M	M	M	M	M	P	P
211	Weather protected, IP xxW.	P	P	P	P	P	P	P
158	Degree of protection IP 65. Dust proof version.	M	M	M	M	M	P	P
211	Weather protected, IP xxW.	P	P	P	P	P	P	P
403	Degree of protection IP 56.	M	M	M	M	M	P	P
404	Degree of protection IP 56, without fan and fan cover. Output on request for sizes 160-250.	NA	P	P	R	R	NA	NA
783	Labyrinth sealing at D-end.	NA	R	R	P	S	S	S
784	Gamma-seal at D-end.	S	S	S	NA	NA	NA	NA
Rating & instruction plates								
002	Restamping voltage, frequency and output, continuous duty.	M	M	M	M	M	P	P
003	Individual serial number.	M	S	S	S	S	S	S
004	Additional text on std rating plate (max 12 digits on free text line)	NA	M	M	M	M	P	P
095	Restamping output (maintained voltage, frequency), intermittent duty.	M	M	M	M	M	P	P
135	Mounting of additional identification plate, stainless.	M	M	M	M	M	P	P
138	Mounting of additional identification plate, aluminum.	M	NA	NA	NA	NA	NA	NA
139	Additional identification plate delivered loose.	M	M	M	M	M	P	P
160	Additional rating plate affixed.	M	M	M	M	M	P	P
161	Additional rating plate delivered loose.	M	M	M	M	M	P	P
163	Frequency converter rating plate. Rating data according to quotation.	NA	M	M	M	M	P	P
Shaft & rotor								
069	Two shaft extensions as per basic catalogue.	NA	P	P	P	P	P	P
070	One or two special shaft extensions, std shaft material.	P	R	R	P	P	P	P
131	Motor delivered with half key (key not exceeding shaft diameter).	R	M	M	NA	NA	NA	NA
164	Shaft extension with closed key-way.	R	S	S	R	R	R	R
165	Shaft extension with open key-way.	S	P	P	S	S	S	S
410	Stainless steel shaft (standard or non-standard design).	NA	R	R	P	P	P	P
427	Shaft extension complies with Australian Standard (AS).	R	NA	NA	P	R	R	R
Standards and regulations								
010	Fulfilling CSA Safety Certificate.	NA	M	M	M	M	P	P
011	Fulfilling CSA Energy Efficiency Verification (code 010 included).	NA	R	R	P	NA	NA	NA
408	Fulfilling Epact certification requirements, CC031A.	NA	NA	NA	P	NA	NA	NA
411	Increased efficiency design, according to IEC 60034-2.	NA	NA	NA	P	P	NA	NA
421	VIK-design (Verband der Industriellen Energie- und Kraftwirtschaft e.V.).	M	M	M	P	P	P	R
756	EDF-design (Electricité de France, non-classified zone).	NA	R	R	P	P	R	R
757	EDF-design (Electricité de France, zone E1 K3).	NA	R	R	P	P	R	R

1) Certain variant codes cannot be used simultaneously.

2) More information available in the Accessories section.

S = Included as standard

M = On modification of a stocked motor,
or on new manufacture,
the number per order may be limited.

P = New manufacture only.

R = On request.

NA = Not applicable

Code 1)	Variant	Motor size						
		71-132	160-180	200-250	280-315	355	400	450
773	EEMUA No 132 1988 design.	NA	R	R	R	R	R	R
774	Design according to NORSOK (Norwegian Territorial Waters). Please ask for specifications.	R	R	R	P	P	P	P
775	Design acc. to SHELL DEP 33.66.0531 Gen. January 1999 design.	P	P	P	M	P	P	NA
778	GOST Export/Import Certificate (Russia).	NA	M	M	M	M	P	P
779	SASO Export/Import Certificate (Saudi Arabia).	M	M	M	M	M	P	P
787	UIC Design (Union of Chemical Industries)	P	P	P	NA	NA	NA	NA

Stator winding temperature sensors

Breaking capacity for bimetal detector:

<u>Sizes 71-100:</u>	<u>Sizes 112-250</u>	<u>Sizes 280-400</u>
2 A at 380 V ac	4 A at 250 V ac	24 A at 250 V
5 A at 240 V ac	3 A at 60 V dc	
2.5 A at 24 V dc		

120	KTY 84-130 (1 per phase) in stator winding.	NA	NA	NA	P	P	P	P
121	Bimetal detectors, break type (NCC), (3 in series), 130°C, in stator winding.	M	M	M	P	P	P	P
122	Bimetal detectors, break type (NCC), (3 in series), 150°C, in stator winding.	M	M	M	P	P	P	P
123	Bimetal detectors, break type (NCC), (3 in series), 170°C, in stator winding.	M	M	M	P	P	P	P
124	Bimetal detectors, break type (NCC), (2x3 in series), 140°C, in stator winding.	NA	M	M	P	P	P	P
125	Bimetal detectors, break type (NCC), (2x3 in series), 150°C, in stator winding.	M	M	M	P	P	P	P
127	Bimetal detectors, break type (NCC), (3 in series, 130°C and 3 in series, 150°C), in stator winding.	M	M	M	P	P	P	P
435	PTC - thermistors (3 in series), 130°C, in stator winding.	M	M	M	M	M	P	P
436	PTC - thermistors (3 in series), 150°C, in stator winding.	S	S	S	S	S	S	S
437	PTC - thermistors (3 in series), 170°C, in stator winding.	M	M	M	M	M	P	P
439	PTC - thermistors (2x3 in series), 150°C, in stator winding. Two speed motors, only for new manufacture.	M	M	M	M	M	P	P
441	PTC - thermistors (3 in series, 130°C and 3 in series, 150°C), in stator winding.	M	M	M	M	M	P	P
442	PTC - thermistors (3 in series, 150°C and 3 in series, 170°C), in stator winding.	M	M	M	M	M	P	P
445	PT100 2-wire in stator winding, 1 per phase.	NA/M	M	M	M	M	P	P
446	PT100 2-wire in stator winding, 2 per phase.	NA/M	M	M	M	M	P	P
502	PT100 3-wire in stator winding, 1 per phase.	NA	NA	NA	M	M	P	P
503	PT100 3-wire in stator winding, 2 per phase.	NA	NA	NA	M	M	P	P

Terminal box

015	Motor supplied in Δ -connection.	M	M	M	NA	NA	NA	NA
017	Motor supplied in Y-connection.	M	M	M	NA	NA	NA	NA
019	Larger than standard terminal box.	NA	NA	NA	P	P	P	NA
021	Terminal box LHS, seen from D-end (= L prod.code).	NA/P	P	P	P	P	P	NA
180	Terminal box RHS, seen from D-end (= R prod.code).	NA/P	P	P	P	P	P	NA
022	Cable entry LHS (seen from D-end).	NA	M	M	M	M	P	P
137	Extended cable connection, low terminal box, 'Flying leads'.	R	NA	NA	NA	NA	NA	NA
413	Extended cable connection, no terminal box.	NA	NA	NA	P	P	P	NA
157	Terminal box degree of protection IP 65.	M	M	M	S	S	S	NA
187	Cable glands of non-standard design. Cable glands or threads to be specified when ordering.	NA	NA	NA	R	R	R	R
230	Standard metal cable glands.	M	M	M	S	S	S	S
231	Standard cable glands with clamping device.	M	R	R	P	P	P	P
400	4 x 90 degr turnable terminal box.	S	S	S	S	S	NA	NA
402	Terminal box adapted for AL cables.	NA	NA	NA	S	S	S	S
409	Large terminal box with two terminal blocks.	NA	NA	NA	P	NA	NA	NA
466	Terminal box at N-end.	R	R	R	P	P	P	P

1) Certain variant codes cannot be used simultaneously.

S = Included as standard
M = On modification of a stocked motor, or on new manufacture, the number per order may be limited.

P = New manufacture only.
R = On request.
NA = Not applicable

Code 1)	Variant	Motor size						
		71- 132	160- 180	200- 250	280- 315	355	400	450
467	Lower than standard terminal box and rubber extended cable. Cable, length 2 m, included.	R	P	P	NA	NA	NA	NA
468	Cable entry from D-end.	M	R	R	M	M	P	NA
469	Cable entry from N-end.	M	M	M	M	M	P	NA
418	Separate terminal box for auxiliaries, standard material.	M	M	M	P	P	P	P
380	Separate terminal box for temperature detectors, standard material.	NA	NA	NA	P	P	P	P
567	Separate terminal box material: cast iron.	NA	NA	NA	P	P	P	P
568	Separate terminal box for heating elements, standard material.	R	R	R	P	P	P	P
569	Separate terminal box for brakes.	NA	R	R	P	P	P	P
447	Top mounted separate terminal box for monitoring equipment.	R	R	R	M	M	NA	NA
729	Cable flanges without holes / Blank gland plates, aluminum.	NA	M	M	M	M	P	P
731	Two standard metal cable glands.	M	M	M	S	S	S	S
743	Painted steel flange for cable glands (blind plate).	NA	M	M	M	M	P	P
744	Stainless steel flange for cable glands (blind plate).	NA	M	M	M	M	P	P
745	Painted steel flange equipped with brass cable glands.	NA	R	R	M	M	P	P
753	Cast iron terminal box.	NA	S	S	S	S	S	S
Testing								
140	Test confirmation.	M	M	M	NA	NA	NA	NA
145	Type test report from a catalogue motor, 400V 50Hz.	M	M	M	M	M	P	P
146	Type test with report for motor from specific delivery batch.	R	M	M	P	P	P	P
147	Type test with report for motor from specific delivery batch, customer witnessed.	R	M	M	P	P	P	P
148	Routine test report. Witnessed routine test = 146.	M	M	M	M	M	P	P
149	Testing according to separate test specification.	R	R	R	R	R	R	R
153	Reduced test for classification society.	R	M	M	NA	NA	NA	NA
221	Type test and multi-point load test with report for motor from spec del batch.	R	M	M	R	R	R	R
222	Torque/speed curve, type test and multi-point load test with report for motor from spec del batch.	NA	M	M	P	P	P	P
760	Vibration level test.	M	M	M	M	M	P	P
761	Vibration spectrum test.	NA	R	R	P	P	P	P
762	Noise level test.	NA	P	P	P	P	P	P
763	Noise spectrum test.	NA	R	R	P	P	P	P
764	Complete test with ABB frequency converter available at ABB test field. Test done with customer supplied converter on request.	R	R	R	P	P	P	P
Variable speed drives								
701	Insulated bearing at N-end.	NA	R	M	M	M	P	P
704	EMC cable gland.	NA	M	M	M	M	P	P
Separate motor cooling								
183	Separate motor cooling (fan axial, N-end).	M	M	M	M	P	P	P
189	Separate motor cooling, IP44, 400V 50Hz (fan axial, N-end).	NA	M	M	NA	NA	NA	NA
422	Separate motor cooling (fan top or side, N-end).	NA	NA	NA	P	P	P	P
Mounting of tacho; tacho not included								
182	Pulse sensor mounted as specified for hollow-shaft.	NA	R	R	P	P	P	P
470	Prepared for hollow shaft pulse tacho (Leine&Linde equivalent).	NA	M	M	P	P	P	P
479	Mounting of pulse tacho with shaft extension, tacho not included.	NA	R	R	P	P	P	P
570	Prepared for hollow shaft pulse tacho (L&L 503).	NA	M	M	NA	NA	NA	NA

1) Certain variant codes cannot be used simultaneously.

2) More information available in the Accessories section.

S = Included as standard
M = On modification of a stocked motor,
or on new manufacture,
the number per order may be limited.

P = New manufacture only.
R = On request.
NA = Not applicable

Code 1)	Variant	Motor size						
		71- 132	160- 180	200- 250	280- 315	355	400	450
Mounting of tacho; tacho included								
062	Tachogenerator.	R	NA	NA	P	P	P	P
472	1024 pulse tacho (Leine&Linde 861) mounted.	NA	M	M	M	P	P	P
473	2048 pulse tacho (Leine&Linde 861) mounted.	NA	M	M	M	P	P	P
572	1024 pulse tacho (L&L 503).	NA	M	M	NA	NA	NA	NA
573	2048 pulse tacho (L&L 503).	NA	M	M	NA	NA	NA	NA
Separate motor cooling & prepared for tacho; tacho not included								
474	Separate motor cooling (fan axial, N-end) and prepared for hollow shaft tacho (Leine&Linde equivalent).	NA	M	M	P	P	P	P
478	Separate motor cooling (fan top, N-end) and prep. for hollow shaft pulse tacho (Leine&Linde equiv).	NA	NA	NA	P	P	P	P
486	Separate motor cooling (fan top, N-end) and prep. for DC-tacho.	NA	NA	NA	P	P	P	P
574	Separate motor cooling (fan axial, N-end) and prepared for hollow shaft tacho (L&L 503).	NA	M	M	NA	NA	NA	NA
578	Separate motor cooling IP 44, 400 V 50 Hz (fan axial, N-end) and prepared for hollow shaft tacho (L&L 503).	NA	M	M	NA	NA	NA	NA
Separate motor cooling & tacho; tacho included								
428	Separate motor cooling (fan top, N-end) and Leine & Linde type 510 pulse tacho mounted.	NA	NA	NA	NA	NA	NA	NA
429	Separate motor cooling (fan top, N-end) and 1024 hollow shaft pulse tacho (Leine & Linde 861) mounted.	NA	NA	NA	P	P	P	P
476	Separate motor cooling (fan axial, N-end) and 1024 pulse tacho (Leine&Linde 861) mounted.	NA	M	M	P	P	P	P
477	Separate motor cooling (fan axial, N-end) and 2048 pulse tacho (Leine&Linde 861) mounted.	NA	M	M	P	P	P	P
576	Separate motor cooling (fan axial, N-end) and 1024 pulse tacho (L&L 503).	NA	M	M	NA	NA	NA	NA
577	Separate motor cooling (fan axial, N-end) and 2048 pulse tacho (L&L 503).	NA	M	M	NA	NA	NA	NA
580	Separate motor cooling IP44, 400V 50Hz (fan axial, N-end) and 1024 pulse tacho (L&L 503).	NA	M	M	NA	NA	NA	NA
581	Separate motor cooling IP44, 400V 50Hz (fan axial, N-end) and 2048 pulse tacho (L&L 503).	NA	M	M	NA	NA	NA	NA
Y/Δ-starting								
117	Terminals for Y/D start at both (two-speed separate windings).	NA	P	P	P	R	R	R
118	Terminals for Y/D start at high speed (two-speed separate windings).	NA	NA	NA	P	R	R	R
119	Terminals for Y/D start at low speed (two-speed separate windings).	NA	R	R	P	R	R	R

1) Certain variant codes cannot be used simultaneously.
2) More information available in the Accessories section.

S = Included as standard
M = On modification of a stocked motor, or on new manufacture, the number per order may be limited.

P = New manufacture only.
R = On request.
NA = Not applicable

LV Process performance cast iron motors Sizes 71-132

Dimension drawings

Foot-mounted: IM B3 (IM 1001), IM B6 (IM 1051), IM B7 (IM 1061), IM B8 (IM 1071), IM V5 (IM 1011), IM V6 (IM 1031)

Terminal box top-mounted

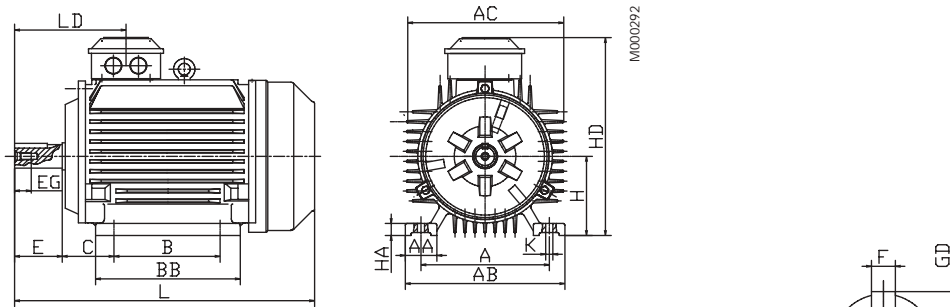

Terminal box on right hand side

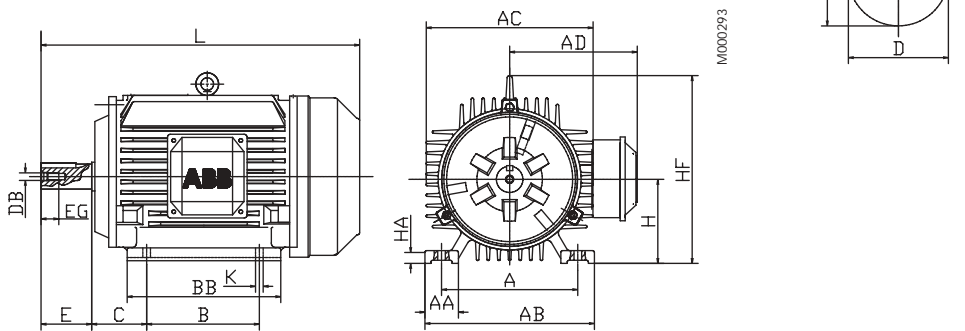

Motor size	Poles	A	AA	AB	AC	AD	B	BB	C	D	DB	E	EG
71	2-6	112	30	145	145	120	90	110	45	14	M5	30	12.5
80	2-6	125	35	160	165	145	100	135	50	19	M6	40	16
90 S	2-6	140	35	175	180	150	100	140	56	24	M8	50	19
90 L	2-6	140	35	175	180	150	125	165	56	24	M8	50	19
100	2-6	160	40	200	205	175	140	180	63	28	M10	60	22
112	2-8	190	50	235	225	185	140	190	70	28	M10	60	22
132 S	2-8	216	55	270	265	205	140	205	89	38	M12	80	28
132 M	2-8	216	55	270	265	205	178	240	89	38	M12	80	28

Motor size	Poles	F	G	GD	H	HA	HD	HF	K	L	LD
71	2-6	5	11	5	71	10	190	-	7	255	100
80	2-6	6	15.5	6	80	12	225	170	10	285	116
90 S	2-6	8	20	7	90	12	240	185	10	310	128
90 L	2-6	8	20	7	90	12	240	185	10	335	128
100	2-6	8	24	7	100	14	275	245	12	380	144
112	2-6	8	24	7	100	15	290	265	12	380	144
132 S	2-6	10	33	8	132	18	335	300	12	465	169
132 M	2-6	10	33	8	132	18	335	300	12	505	169

Tolerances:

A, B	± 0.8	F	ISO h9
C	± 0.8	H	+0 -0.5
D	ISO j6	N	ISO j6

Above table gives the main dimensions in mm.

For detailed drawings please see our web-pages 'www.abb.com/motors&drives' or contact us.

LV Process performance cast iron motors Sizes 71-132

Dimension drawings

Flange-mounted; IM B5 (IM 3001), V1 (IM 3011), V3 (IM 3031) and IM B14 (IM 3601), V18 (IM 3611), V19 (IM 3631)

Large flange (B5)

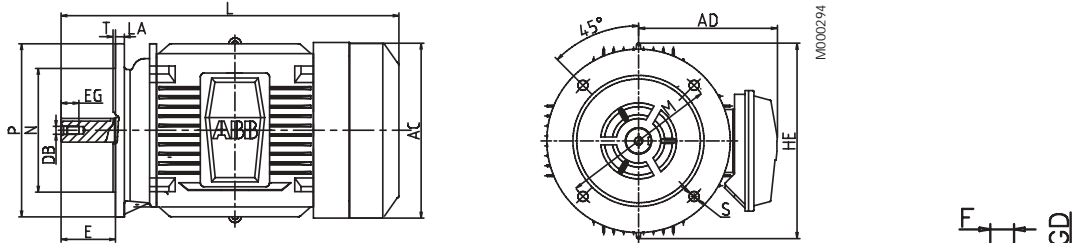

Small flange (B14)

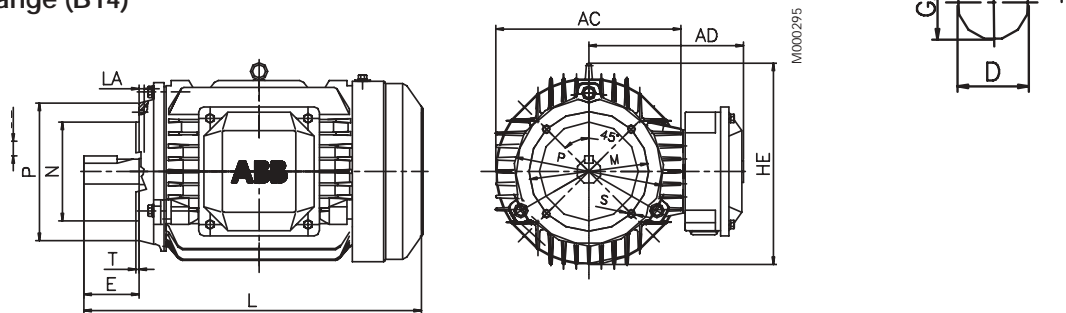

IM B5 (IM 3001), IM V1 (IM 3011), IM V3 (IM 3031)

Motor size	Poles	AC	AD	D	DB	E	EG	F	G	GD	HE	L	LA	M	N	P	S	T
71	2-6	145	120	14	M5	30	12.5	5	11	5	165	255	9	130	110	160	10	3.5
80	2-8	165	145	19	M6	40	16	6	15.5	6	200	285	9	165	130	200	12	3.5
90 S	2-8	180	150	24	M8	50	19	8	20	7	200	310	10	165	130	200	12	3.5
90 L	2-8	180	150	24	M8	50	19	8	20	7	200	335	10	165	130	200	12	3.5
100	2-8	205	175	28	M10	60	22	8	24	7	265	380	11	215	180	250	15	4
112	2-8	225	185	28	M10	60	22	8	24	7	270	395	11	215	180	250	15	4
132 S	2-8	265	205	38	M12	80	28	10	33	8	320	465	12	265	230	300	15	4
132 M	2-8	265	205	38	M12	80	28	10	33	8	320	505	12	265	230	300	15	4

IM B14 (IM 3601), IM V18 (IM 3611), IM V19 (IM 3631)

Motor size	Pole	Flange size	HE	P	M	N	S	T
71	2-6	C105	145	105	85	70	M6	2.5
		C140	145	140	115	95	M8	3
80	2-8	C120	165	120	100	80	M6	3
		C160	165	160	130	110	M8	3.5
90 S	2-8	C140	185	140	115	95	M8	3
		C160	185	160	130	110	M8	3.5
90 L	2-8	C140	185	140	115	95	M8	3
		C160	185	160	130	110	M8	3.5
100	2-8	C160	255	160	130	110	M8	3.5
		C200	255	200	165	130	M10	3.5
112	2-8	C160	265	160	130	110	M8	3.5
		C200	265	200	165	130	M10	3.5

Tolerances:

D. DA ISO m6
F. FA ISO h9
N ISO j6

Above table gives the main dimensions in mm.

For detailed drawings please see our web-pages 'www.abb.com/motors&drives' or contact us.

LV Process performance cast iron motors Sizes 71-132

Dimension drawings

Foot- and flange-mounted: IM B35 (IM 2001), IM V15 (IM 2011), IM V36 (IM 2031)

Terminal box top-mounted

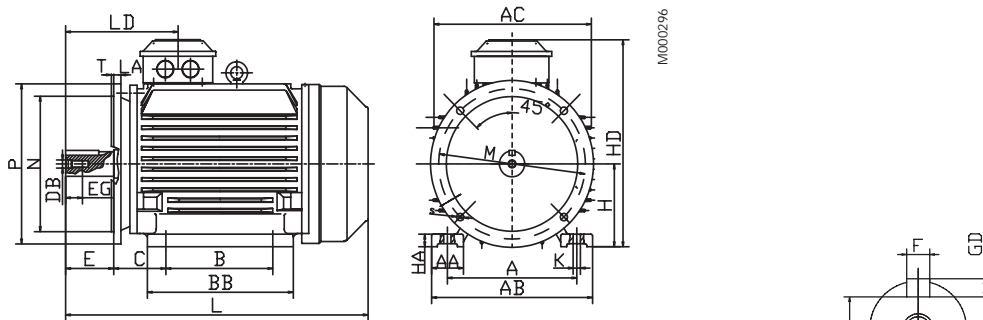

Terminal box on right hand side

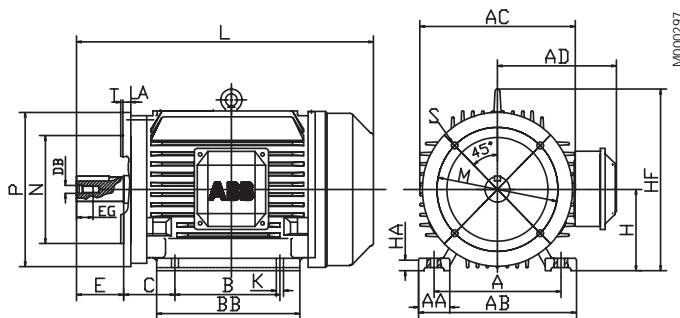

Motor size	Poles	A	AA	AB	AC	AD	B	BB	C	D	DB	E	EG	F
71	2-6	112	30	145	145	120	90	110	45	14	M5	30	12.5	5
80	2-8	125	35	160	165	145	100	135	50	19	M6	40	16	6
90 S	2-8	140	35	175	180	150	100	140	56	24	M8	50	19	8
90 L	2-8	140	35	175	180	150	125	165	56	24	M8	50	19	8
100	2-8	160	40	200	205	175	140	180	63	28	M10	60	22	8
112	2-8	190	50	235	225	185	140	190	70	28	M10	60	22	8
132 S	2-8	216	55	270	265	205	140	205	89	38	M12	80	28	10
132 M	2-8	216	55	270	265	205	178	240	89	38	M12	80	28	10

Motor size	Poles	G	GD	H	HA	HD	HF	K	L	LA	LD	M	N	P	S	T
71	2-6	11	5	71	10	200	-	7	255	9	100	130	110	160	10	3.5
80	2-8	15.5	6	80	12	225	170	10	285	9	116	165	130	200	12	3.5
90 S	2-8	20	7	90	12	240	185	10	310	10	128	165	130	200	12	3.5
90 L	2-8	20	7	90	12	240	185	10	335	10	128	165	130	200	12	3.5
100	2-8	24	7	100	14	275	245	12	380	11	138	215	180	250	15	4
112	2-8	24	7	112	15	290	265	12	395	11	144	215	180	250	15	4
132 S	2-8	33	8	132	18	335	300	12	465	12	169	265	230	300	15	4
132 M	4-8	33	8	132	18	335	300	12	505	12	169	265	230	300	15	4

Tolerances:

A, B	± 0.8	H	+0 -0.5
D	ISO j6 (size 71)	N	ISO j6
	ISO k6 (sizes 80-112)	C	± 0.8
F	ISO h9		

Above table gives the main dimensions in mm.

For detailed drawings please see our web-pages 'www.abb.com/motors&drives' or contact us.

LV Process performance cast iron motors Sizes 160-250

Dimension drawings

Foot-mounted: IM B3 (IM 1001), IM B6 (IM 1051), IM B7 (IM 1061), IM B8 (IM 1071), IM V5 (IM 1011), IM V6 (IM 1031)

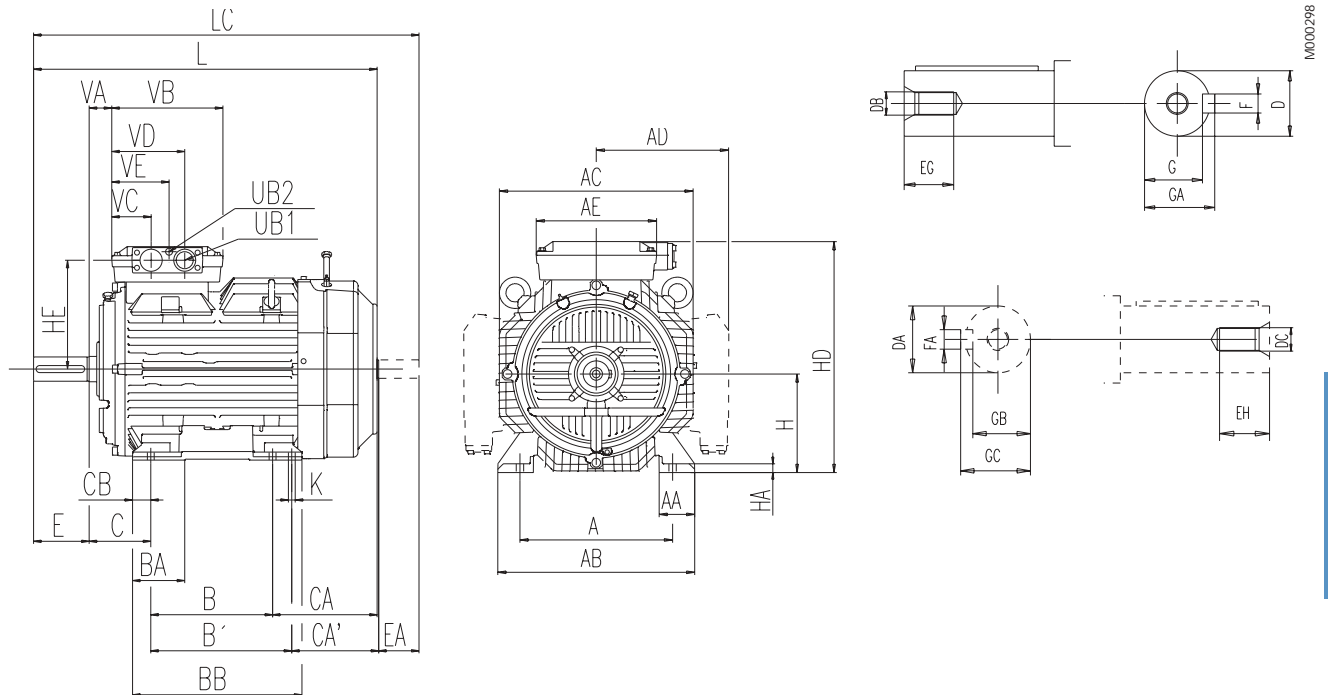

Motor size	Poles	A	AA	AB	AC	AD	AE	B	B'	BA	BB	C	CA	CA'	CB	D	DA	DB	DC	E	EA	EG	EH	F	FA
160 ¹⁾	2-8	254	60	320	316	225	220	210	254	104	299	108	185.5	141.5	17	42	32	M16	M12	110	80	36	28	12	10
160L ²⁾	2-8	254	60	320	316	225	220	210	254	104	299	108	226.5	182.5	17	42	32	M16	M12	110	80	36	28	12	10
180 ³⁾	2-8	279	65	360	356	243	220	241	279	103	335	121	249	180	35	48	32	M16	M12	110	80	36	28	14	10
180L ⁴⁾	2-8	279	65	360	356	243	220	241	279	103	335	121	238	200	35	48	32	M16	M12	110	80	36	28	14	10
200ML	2-8	318	65	390	390	305	312	267	305	111	378	133	273	235	37	55	45	M20	M16	110	110	42	36	16	14
225SM	2	356	74	432	430	325	312	286	311	112	393	149	330	305	30	55	55	M20	M20	110	110	42	42	16	16
225SM	4-8	356	74	432	430	325	312	286	311	112	393	149	270	245	30	60	55	M20	M20	140	110	42	42	18	16
250SM	2	406	81	480	480	353	312	311	349	105	441	168	263	225	69	60	55	M20	M20	140	110	42	42	18	16
250SM	4-8	406	81	480	480	353	312	311	349	105	441	168	263	225	69	65	55	M20	M20	140	110	42	42	18	16

Motor size	Poles	G	GA	GB	GC	H	HA	HD	HE	K	L	LC	UB1	UB2	VA	VB	VC	VD	VE
160 ¹⁾	2-8	37	45	27	35	160	17	385	195	14.5	602.5	693.5	M40	M16	56	220	76.5	143.5	110
160L ²⁾	2-8	37	45	27	35	160	17	385	195	14.5	643.5	734.5	M40	M16	56	220	76.5	143.5	110
180 ³⁾	2-8	42.5	51.5	27	35	180	16	425	215	14.5	680	770	M40	M16	43.5	220	76.5	143.5	110
180L ⁴⁾	2-8	42.5	51.5	27	35	180	16	425	215	14.5	700.5	790	M40	M16	43.5	220	76.5	143.5	110
200ML	2-8	49	59	39.5	48.5	200	22	505	255	18.5	774	893	M63	M16	35.5	310	110	200	155
225SM	2	49	59	49	59	225	22	550	275	18.5	836	985	M63	M16	53.5	310	110	200	155
225SM	4-8	53	64	49	59	225	22	550	275	18.5	866	955	M63	M16	53.5	310	110	200	155
250SM	2	53	64	49	59	250	26	603	283	24	845	992	M63	M16	53	310	110	200	155
250SM	4-8	58	69	49	59	250	26	603	283	24	875	992	M63	M16	53	310	110	200	155

Tolerances:

A, B	± 0,8	F, FA	ISO h9
C, CA	± 0,8	H	+0 -0.5
D, DA	ISO k6 < Ø 50mm		
	ISO m6 > Ø 50mm		

¹⁾ MA2, M2, L2, LB2, M4, L4, LB4, M6, L6, MA8, M8, MA2/4, M2/4, L2/4, M4/6, M4/8

²⁾ LB6, L8, LB8, L4/6, L4/8

³⁾ M2, LB2, M4, L6, L8, M2/4, M4/6, M4/8

⁴⁾ L4, LB4, LB6, LB8, L2/4, L4/6, L4/8

Above table gives the main dimensions in mm.

For detailed drawings please see our web-pages 'www.abb.com/motors&drives' or contact us.

LV Process performance cast iron motors Sizes 160-250

Dimension drawings

Flange-mounted; IM B5 (IM 3001) , V1 (IM 3011), V3 (IM 3031) and IM B14 (IM 3601), V18 (IM 3611), V19 (IM 3631)

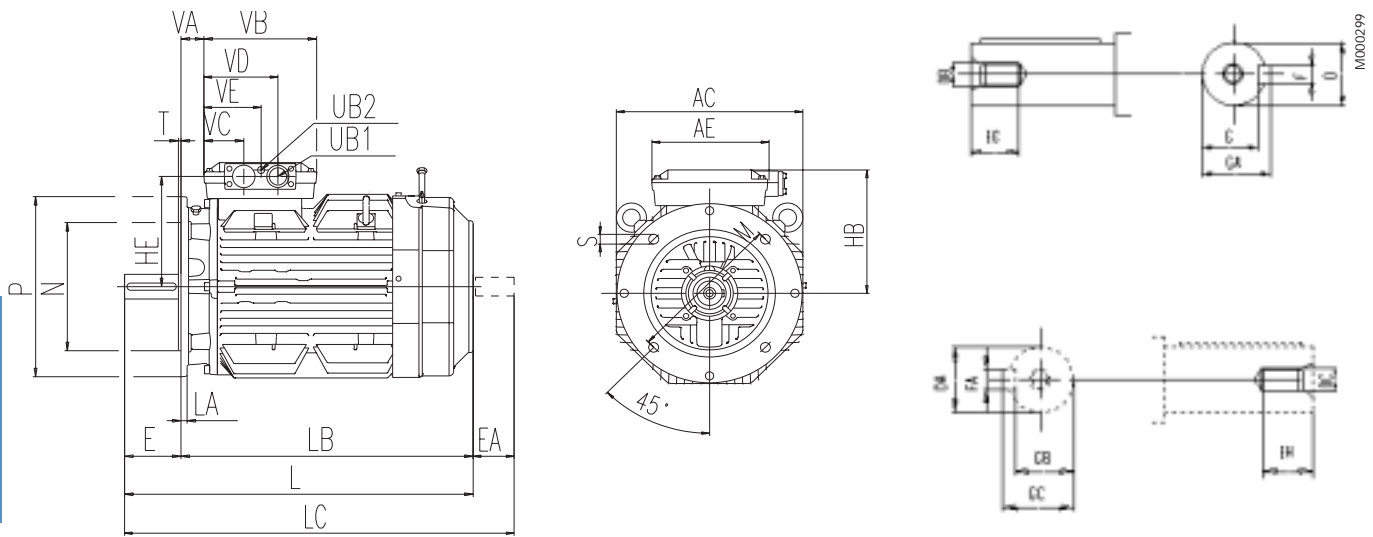

Motor size	Poles	AC	AE	D	DA	DB	DC	E	EA	EG	EH	F	FA	G	GA	GB	GC	HB	HE	L
160_ ¹⁾	2-8	316	220	42	32	M16	M12	110	80	36	28	12	10	37	45	27	35	225	195	602.5
160L ²⁾	2-8	316	220	42	32	M16	M12	110	80	36	28	12	10	37	45	27	35	225	195	643.5
180_ ³⁾	2-8	356	220	48	32	M16	M12	110	80	36	28	14	10	42.5	51.5	27	35	243	215	680
180L ⁴⁾	2-8	356	220	48	32	M16	M12	110	80	36	28	14	10	42.5	51.5	27	35	243	215	700.5
200ML	2-8	390	312	55	45	M20	M16	110	110	42	36	16	14	49	59	39.5	48.5	305	255	774
225SM	2	430	312	55	55	M20	M20	110	110	42	42	16	16	49	59	49	59	325	275	836
225SM	4-8	430	312	60	55	M20	M20	140	110	42	42	18	16	53	64	49	59	325	275	866
250SM	2	480	312	60	55	M20	M20	140	110	42	42	18	16	53	64	49	59	353	283	875
250SM	4-8	480	312	65	55	M20	M20	140	110	42	42	18	16	58	69	49	59	353	283	875

Motor size	Poles	LA	LB	LC	M	N	P	S	T	UB1	UB2	VA	VB	VC	VD	VE
160_ ¹⁾	2-8	18	492.5	693.5	300	250	350	19	5	M40	M16	56	220	76.5	143.5	110
160L ²⁾	2-8	18	533.5	734.5	300	250	350	19	5	M40	M16	56	220	76.5	143.5	110
180_ ³⁾	2-8	20	570	770	300	250	350	19	5	M40	M16	43.5	220	76.5	143.5	110
180L ⁴⁾	2-8	20	590.5	790	300	250	350	19	5	M40	M16	43.5	220	76.5	143.5	110
200ML	2-8	19.5	664	893	350	300	400	19	5	M63	M16	35.5	310	110	200	155
225SM	2	21	726	985	400	350	450	19	5	M63	M16	53.5	310	110	200	155
225SM	4-8	21	726	955	400	350	450	19	5	M63	M16	53.5	310	110	200	155
250SM	2	25	735	992	500	450	550	19	5	M63	M16	53.5	310	110	200	155
250SM	4-8	25	735	992	500	450	550	19	5	M63	M16	53.5	310	110	200	155

Tolerances:

D, DA	ISO k6 < Ø 50mm ISO m6 > Ø 50mm
F, FA	ISO h9
N	ISO j6

- ¹⁾ MA2, M2, L2, LB2, M4, L4, LB4, M6, L6, MA8, M8, MA2/4, M2/4, L2/4, M4/6, M4/8
- ²⁾ LB6, L8, LB8, L4/6, L4/8
- ³⁾ M2, LB2, M4, L6, L8, M2/4, M4/6, M4/8
- ⁴⁾ L4, LB4, LB6, LB8, L2/4, L4/6, L4/8

Above table gives the main dimensions in mm.

For detailed drawings please see our web-pages 'www.abb.com/motors&drives' or contact us.

LV Process performance cast iron motors Sizes 160-250

Dimension drawings

Foot- and flange-mounted: IM B35 (IM 2001), IM V15 (IM 2011), IM V36 (IM 2031)

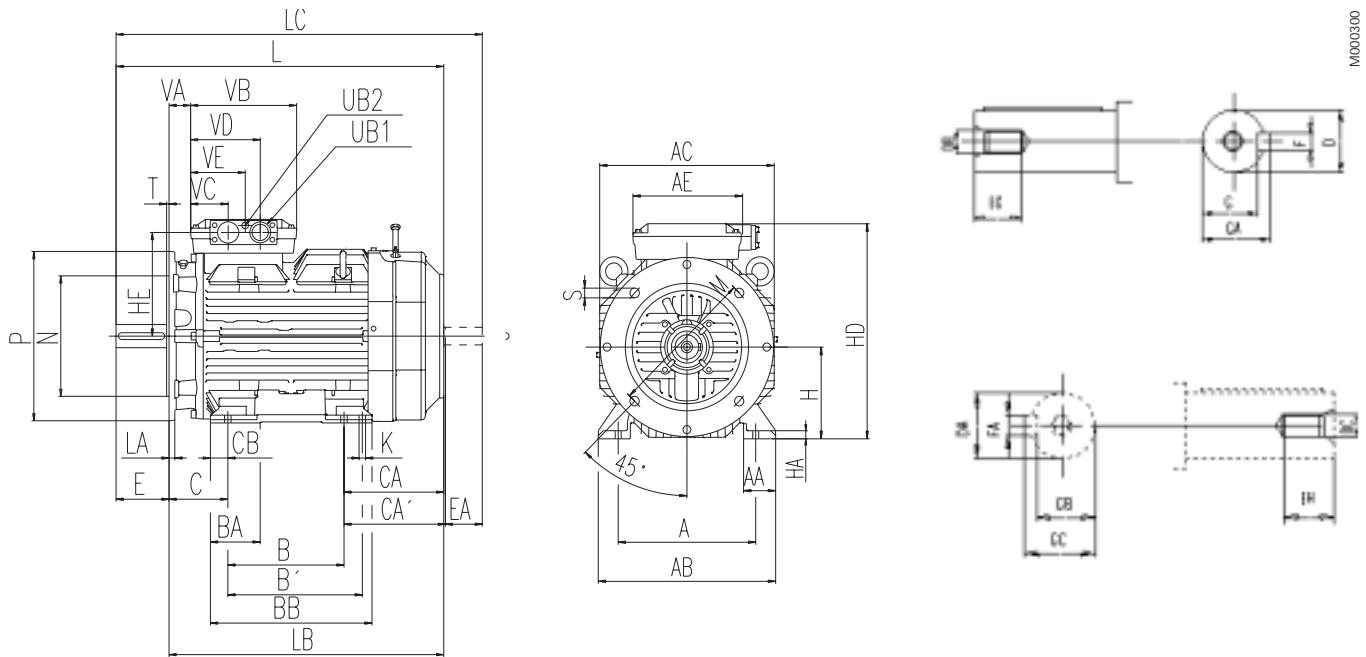

M000300

2

Motor size	Poles	A	AA	AB	AC	AE	B	B'	BA	BB	C	CA	CA'	CB	D	DA	DB	DC	E	EA	EG	EH	F	FA	G	GA
160 ¹⁾	2-8	254	60	320	316	220	210	254	104	299	108	185.5	141.5	17	42	32	M16	M12	110	80	36	28	12	10	37	45
160L ²⁾	2-8	254	60	320	316	220	210	254	104	299	108	226.5	182.5	17	42	32	M16	M12	110	80	36	28	12	10	37	45
180 ³⁾	2-8	279	65	360	356	220	241	279	103	335	121	249	180	35	48	32	M16	M12	110	80	36	28	14	10	42.5	51.5
180L ⁴⁾	2-8	279	65	360	356	220	241	279	103	335	121	238	200	35	48	32	M16	M12	110	80	36	28	14	10	42.5	51.5
200ML	2-8	318	65	390	390	312	267	305	111	378	133	273	235	37	55	45	M20	M16	110	110	42	36	16	14	49	59
225SM	2	356	74	432	430	312	286	311	112	393	149	330	305	30	55	55	M20	M20	110	110	42	42	16	16	49	59
225SM	4-8	356	74	432	430	312	286	311	112	393	149	270	245	30	60	55	M20	M20	140	110	42	42	18	16	53	64
250SM	2	406	81	480	480	312	311	349	105	441	168	263	225	69	60	55	M20	M20	140	110	42	42	18	16	53	64
250SM	4-8	406	81	480	480	312	311	349	105	441	168	263	225	69	65	55	M20	M20	140	110	42	42	18	16	58	69

Motor size	Poles	GB	GC	H	HA	HD	HE	K	L	LA	LB	LC	M	N	P	S	T	UB1	UB2	VA	VB	VC	VD	VE
160 ¹⁾	2-8	27	35	160	17	385	195	14.5	602.5	18	492.5	694	300	250	350	19	5	M40	M16	56	220	76.5	143.5	100
160L ²⁾	2-8	27	35	160	17	385	195	14.5	643.5	18	533.5	735	300	250	350	19	5	M40	M16	56	220	76.5	143.5	110
180 ³⁾	2-8	27	35	180	16	425	215	14.5	680	20	570	770	300	250	350	19	5	M40	M16	43.5	220	76.5	143.5	110
180L ⁴⁾	2-8	27	35	180	16	425	215	14.5	700.5	20	590.5	790	300	250	350	19	5	M40	M16	43.5	220	76.5	143.5	110
200ML	2-8	39.5	48.5	200	22	505	255	18.5	774	19.5	664	893	350	300	400	19	5	M63	M16	35.5	310	110	200	155
225SM	2	49	59	225	22	550	275	18.5	836	21	726	985	400	350	450	19	5	M63	M16	53.5	310	110	200	155
225SM	4-8	49	59	225	22	550	275	18.5	866	21	726	955	400	350	450	19	5	M63	M16	53.5	310	110	200	155
250SM	2	49	59	250	26	603	283	24	845	25	735	992	500	450	550	19	5	M63	M16	53	310	110	200	155
250SM	4-8	49	59	250	26	603	283	24	875	25	735	992	500	450	550	19	5	M63	M16	53	310	110	200	155

Tolerances:

A, B	± 0,8	F, FA	ISO h9
C, CA	± 0,8	H	+0 -0,5
D, DA	ISO k6 < Ø 50 mm	N	ISO j6
	ISO m6 > Ø 50 mm		

¹⁾ MA2, M2, L2, LB2, M4, L4, LB4, M6, L6, MA8, M8, MA2/4, M2/4, L2/4, M4/6, M4/8

²⁾ LB6, L8, LB8, L4/6, L4/8

³⁾ M2, LB2, M4, L6, L8, M2/4, M4/6, M4/8

⁴⁾ L4, LB4, LB6, LB8, L2/4, L4/6, L4/8

Above table gives the main dimensions in mm.

For detailed drawings please see our web-pages 'www.abb.com/motors&drives' or contact us.

LV Process performance cast iron motors Sizes 280-315

Dimension drawings

Foot-mounted: IM B3 (IM 1001), IM B6 (IM 1051), IM B7 (IM 1061), IM B8 (IM 1071), IM V5 (IM 1011), IM V6 (IM 1031)

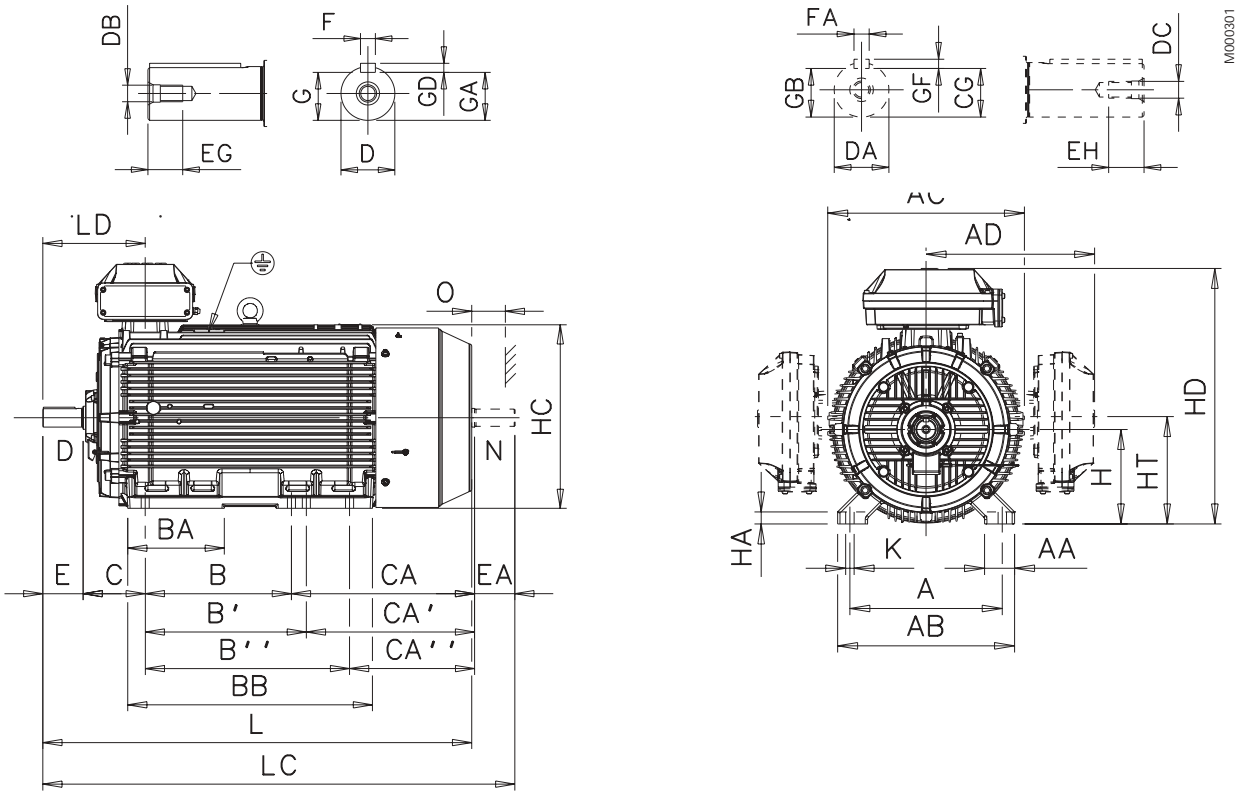

Motor size	Poles	A	AA	AB	AC	AD ¹⁾	AD ²⁾	B	B'	B''	BA	BB	C	CA	CA'	CA''	D	DA	DB	DC	E	EA	EG	EH
280 SM ₋	2	457	84	530	577	481	-	368	419	-	147	506	190	400	349	-	65	60	M20	M20	140	140	40	40
	4-12	457	84	530	577	481	-	368	419	-	147	506	190	400	349	-	75	65	M20	M20	140	140	40	40
315 SM ₋	2	508	100	590	654	545	-	406	457	-	180	558	216	420	369	-	65	60	M20	M20	140	140	40	40
	4-12	508	100	590	654	545	-	406	457	-	180	558	216	420	369	-	80	75	M20	M20	170	140	40	40
315 ML ₋	2	508	100	590	654	545	-	457	508	-	212	669	216	480	429	-	65	60	M20	M20	140	140	40	40
	4-12	508	100	590	654	545	-	457	508	-	212	669	216	480	429	-	90	75	M24	M20	170	140	48	40
315 LK ₋	2	508	100	590	654	562	576	508	560	710	336	851	216	635	583	433	65	60	M20	M20	140	140	40	40
	4-12	508	100	590	654	562	576	508	560	710	336	851	216	635	583	433	90	75	M24	M20	170	140	48	40

Motor size	Poles	F	FA	G	GA	GB	GC	GD	GF	H	HA	HC	HD ¹⁾	HD ²⁾	HT	K	L	LC	LD	LD	O
													top-m.	top-m.					top-m.	side-m.	
280 SM ₋	2	18	18	58	69	53	64	11	11	280	31	564	762	-	337.5	24	1088	1238	336	539	100
	4-12	20	18	67.5	79.5	58	69	12	11	280	31	564	762	-	337.5	24	1088	1238	336	539	100
315 SM ₋	2	18	18	58	69	53	64	11	11	315	40	638	852	-	375	28	1174	1322	356	585	115
	4-12	22	20	71	85	67.5	79.5	14	12	315	40	638	852	-	375	28	1204	1352	386	615	115
315 ML ₋	2	18	18	58	69	53	64	11	11	315	40	638	852	-	375	28	1285	1433	356	640	115
	4-12	25	20	81	95	67.5	79.5	14	12	315	40	638	852	-	375	28	1315	1463	386	670	115
315 LK ₋	2	18	18	58	69	53	64	11	11	315	40	638	870	880	359	28	1491	1639	356	721	115
	4-12	25	20	81	95	67.5	79.5	14	12	315	40	638	852	880	359	28	1521	1669	386	751	115

Tolerances:

A, B	± 0,8	F	ISO h9
C, CA	± 0,8	H	+0 -0,5
D	ISO k6 < Ø 50mm	N	ISO j6
	ISO m6 > Ø 50mm		

¹⁾ Terminal box 370

²⁾ Terminal box 750

Above table gives the main dimensions in mm.

For detailed drawings please see our web-pages 'www.abb.com/motors&drives' or contact us.

LV Process performance cast iron motors Sizes 280-315

Dimension drawings

Flange-mounted; IM B5 (IM3001) , V1 (IM3011), V3 (IM3031) and IM B14 (IM3601),
V18 (IM3611), V19 (IM3631)

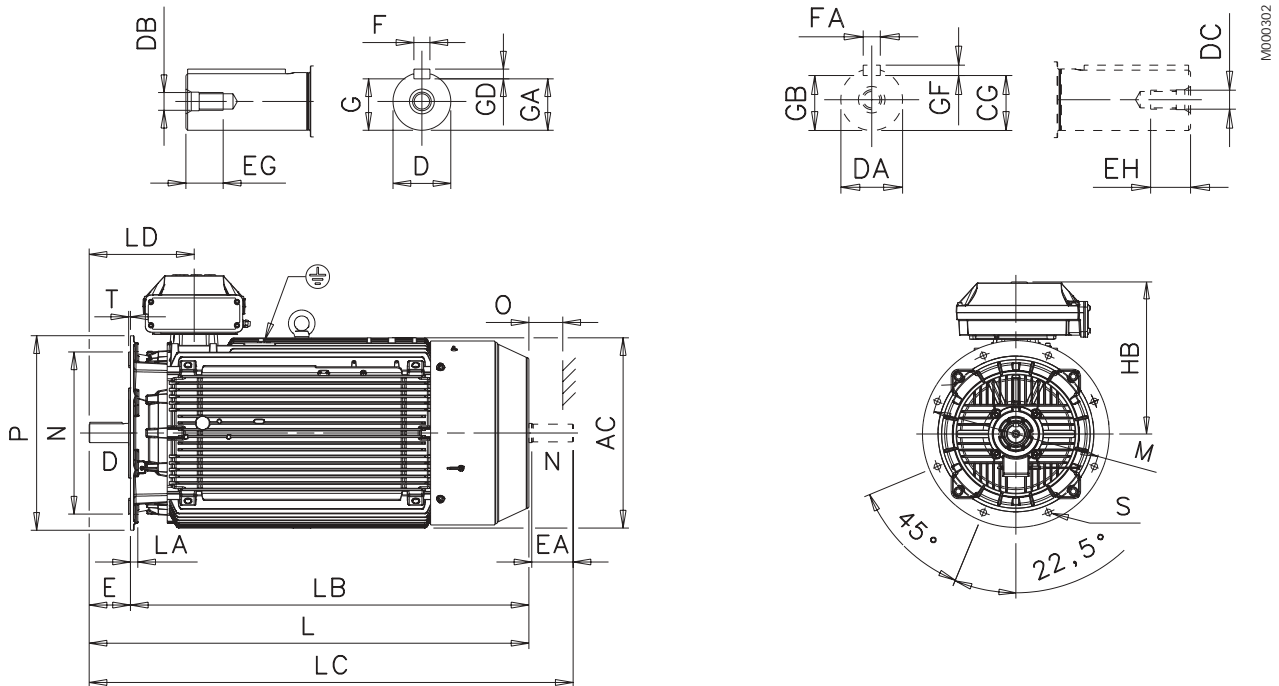

Motor size	Poles	AC	D	DA	DB	DC	E	EA	EG	EH	F	FA	G	GA	GB	GC	GD	GF
280 SM_	2	577	65	60	M20	M20	140	140	40	40	18	18	58	69	53	64	11	11
	4-12	577	75	65	M20	M20	140	140	40	40	20	18	67.5	79.5	58	69	12	11
315 SM_	2	645	65	60	M20	M20	140	140	40	40	18	18	58	69	53	64	11	11
	4-12	645	80	75	M20	M20	170	140	40	40	22	20	71	85	67.5	79.5	14	12
315 ML_	2	645	65	60	M20	M20	140	140	40	40	18	18	58	69	53	64	11	11
	4-12	645	90	75	M24	M20	170	140	48	40	25	20	81	95	67.5	79.5	14	12
315 LK_	2	645	65	60	M20	M20	140	140	40	40	18	18	58	69	53	64	11	11
	4-12	645	90	75	M24	M20	170	140	48	40	25	20	81	95	67.5	79.5	14	12

Motor size	Poles	HB ¹⁾	HB ²⁾	L	LA	LB	LC	LD	M	N	O	P	S	T
280 SM_	2	482	-	1088	23	948	1238	336	500	450	100	550	18	5
	4-12	482	-	1088	23	948	1238	336	500	450	100	550	18	5
315 SM_	2	537	-	1174	25	1034	1322	356	600	550	115	660	23	6
	4-12	537	-	1204	25	1034	1352	386	600	550	115	660	23	6
315 ML_	2	537	-	1285	25	1145	1433	356	600	550	115	660	23	6
	4-12	537	-	1315	25	1145	1463	386	600	550	115	660	23	6
315 LK_	2	537	565	1491	25	1306	1639	356	600	550	115	660	23	6
	4-12	537	565	1521	25	1306	1669	386	600	550	115	660	23	6

Tolerances:

D, DA ISO m6 N ISO j6 (280 SM_)
F, FA ISO h9 ISO js6 (315_)

¹⁾ Terminal box 370

²⁾ Terminal box 750

Above table gives the main dimensions in mm.

For detailed drawings please see our web-pages 'www.abb.com/motors&drives' or contact us.

LV Process performance cast iron motors Sizes 280-315

Dimension drawings

Foot- and flange-mounted: IM B35 (IM 2001), IM V15 (IM 2011), IM V36 (IM 2031)

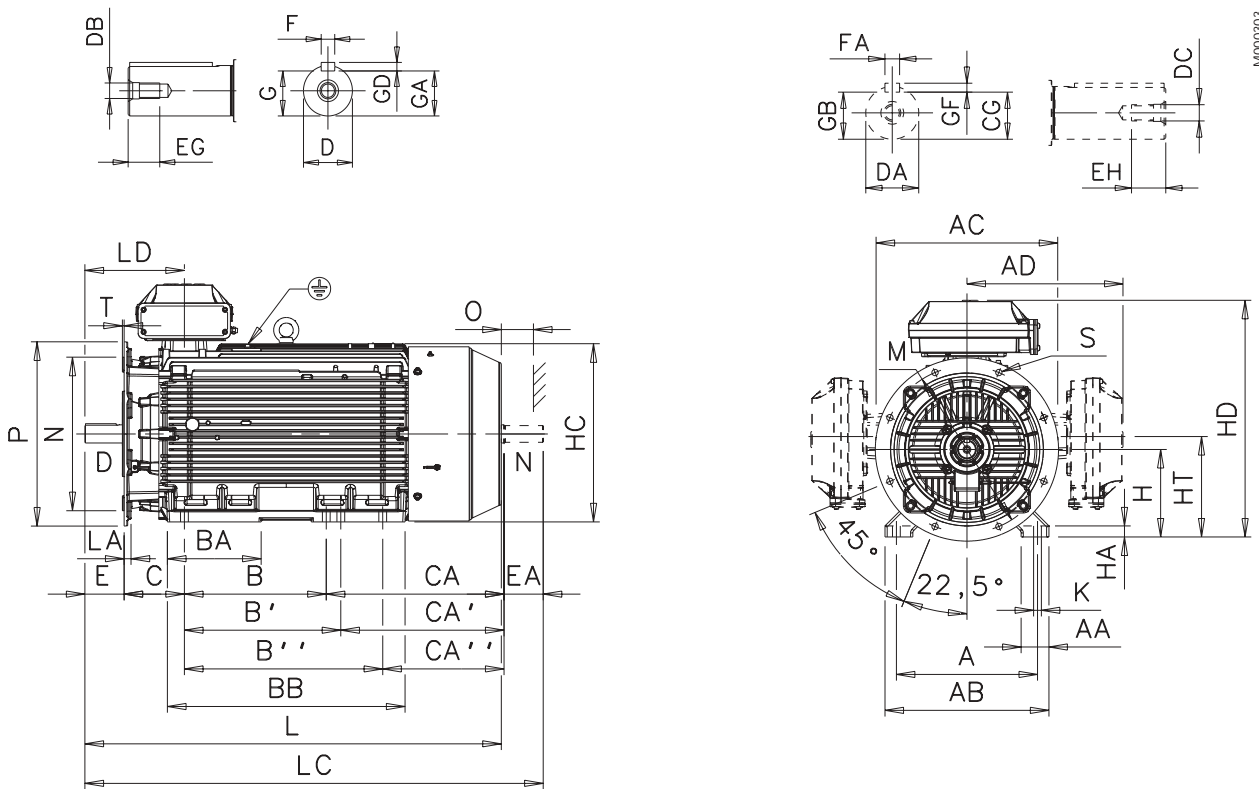

Motor size	Poles	A	AA	AB	AC	AD ¹⁾	AD ²⁾	B	B'	B''	BA	BB	C	CA	CA'	CA''	D	DA	DB	DC	E	EA	EG	EH	F	FA	G
280 SM_	2	457	84	530	577	481	-	368	419	-	147	506	190	400	349	-	65	60	M20	M20	140	140	40	40	18	18	58
	4-12	457	84	530	577	481	-	368	419	-	147	506	190	400	349	-	75	65	M20	M20	140	140	40	40	20	18	67.5
315 SM_	2	508	100	590	654	545	-	406	457	-	180	558	216	420	369	-	65	60	M20	M20	140	140	40	40	18	18	58
	4-12	508	100	590	654	545	-	406	457	-	180	558	216	420	369	-	80	75	M20	M20	170	140	40	40	22	20	71
315 ML_	2	508	100	590	654	545	-	457	508	-	212	669	216	480	429	-	65	60	M20	M20	140	140	40	40	18	18	58
	4-12	508	100	590	654	545	-	457	508	-	212	669	216	480	429	-	90	75	M24	M20	170	140	48	40	25	20	81
315 LK_	2	508	100	590	654	562	576	508	560	710	336	851	216	635	583	433	65	60	M20	M20	140	140	40	40	18	18	58
	4-12	508	100	590	654	562	576	508	560	710	336	851	216	635	583	433	90	75	M24	M20	170	140	48	40	25	20	81

Motor size	Poles	GA	GB	GC	GD	GF	H	HA	HC	HD ¹⁾	HD ²⁾	HT	K	L	LA	LC	LD	LD	M	N	P	S	T	O
										top-m.	top-m.						top-m.	side-m.						
280 SM_	2	69	53	64	11	11	280	31	564	762	-	337.5	24	1088	23	1238	336	539	500	450	550	18	5	100
	4-12	79.5	58	69	12	11	280	31	564	762	-	337.5	24	1088	23	1238	336	539	500	450	550	18	5	100
315 SM_	2	69	53	64	11	11	315	40	638	852	-	375	28	1174	25	1322	356	585	600	550	660	23	6	115
	4-12	85	67.5	79.5	14	12	315	40	638	852	-	375	28	1204	25	1352	386	615	600	550	660	23	6	115
315 ML_	2	69	53	64	11	11	315	40	638	852	-	375	28	1285	25	1433	356	640	600	550	660	23	6	115
	4-12	95	67.5	79.5	14	12	315	40	638	852	-	375	28	1315	25	1463	386	670	600	550	660	23	6	115
315 LK_	2	69	53	64	11	11	315	40	638	852	880	359	28	1491	25	1639	356	721	600	550	660	23	6	115
	4-12	95	67.5	79.5	14	12	315	40	638	852	880	359	28	1521	25	1669	386	751	600	550	660	23	6	115

Tolerances:

A, B	± 0,8	N	ISO j6 (280 SM_)
D	ISO m6		ISO js6 (315_)
F	ISO h9	C	± 0.8
H	+0 -1.0		

¹⁾ Terminal box 370

²⁾ Terminal box 750

Above table gives the main dimensions in mm.

For detailed drawings please see our web-pages 'www.abb.com/motors&drives' or contact us.

LV Process performance cast iron motors Sizes 355-450

Dimension drawings

Foot-mounted: IM B3 (IM 1001), IM B6 (IM 1051), IM B7 (IM 1061), IM B8 (IM 1071), IM V5 (IM 1011), IM V6 (IM 1031)

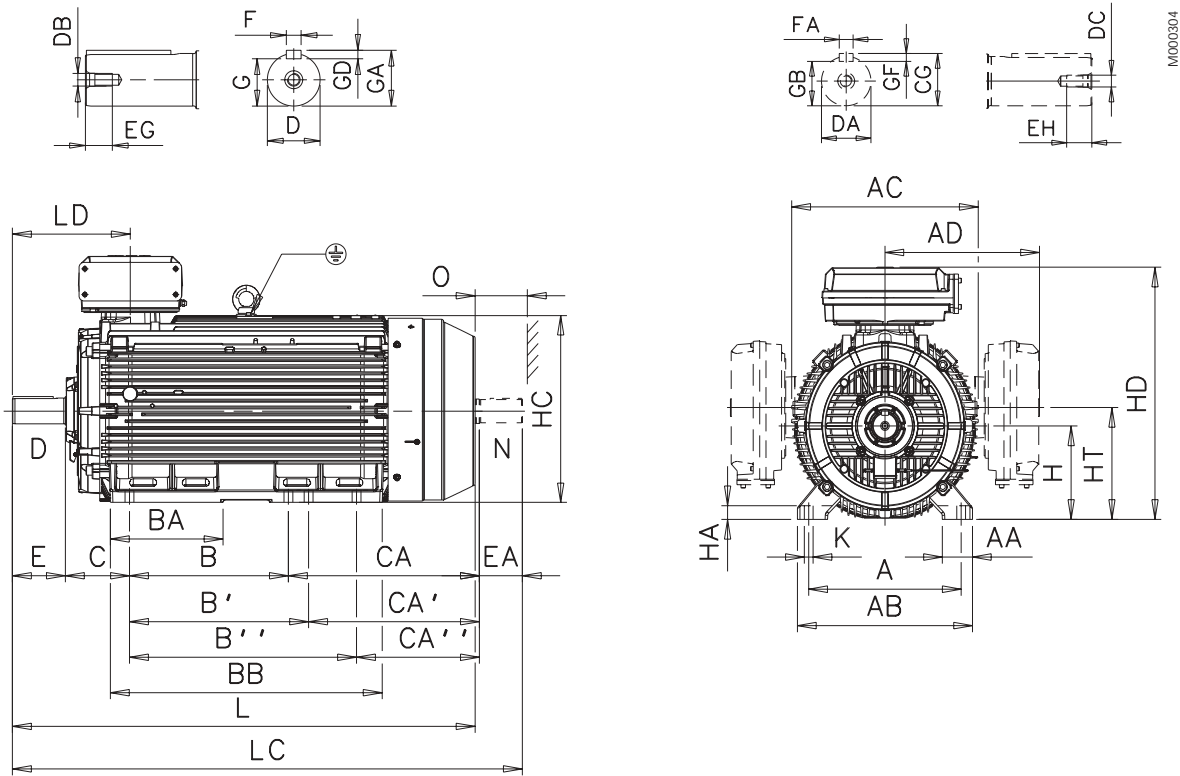

Motor size	Poles	A	AA	AB	AC	AD ¹⁾	AD ²⁾	B	B'	B''	BA	BB	C	CA	CA'	CA''	D	DA	DB	DC	E	EA	EG	EH
355 SM ₋	2	610	120	700	746	604	618	500	560	-	221	722	254	525	465	-	70	70	M20	M20	140	140	42	40
	4-12	610	120	700	746	604	618	500	560	-	221	722	254	525	465	-	100	90	M24	M24	210	170	51	51
355 ML ₋	2	610	120	700	746	604	618	560	630	-	267	827	254	500	570	-	70	70	M20	M20	140	140	42	40
	4-12	610	120	700	746	604	618	560	630	-	267	827	254	500	570	-	100	90	M24	M24	210	170	51	51
355 LK ₋₄₎	2	610	120	700	746	604	618	630	710	900	447	1077	254	750	670	480	70	70	M20	M20	140	140	42	40
	4-12	610	120	700	746	604	618	630	710	900	447	1077	254	750	670	480	100	90	M24	M24	210	170	51	51
400 L ₋	2	710	150	840	834	-	660	900	1000	-	410	1156	224	567	467	-	80	70	M20	M20	170	140	42	40
	4-12	710	150	840	834	-	660	900	1000	-	410	1156	224	567	467	-	110	90	M24	M24	210	170	50	51
400 LK ₋₄₎	2	686	150	840	834	-	660	710	800	900	410	1156	280	701	611	511	80	70	M20	M20	170	140	42	40
	4-12	686	150	840	834	-	660	710	800	900	410	1156	280	701	611	511	100	90	M24	M24	210	170	50	51
450 L ₋	2	800	160	950	966	-	-	1000	1120	1250	450	1420	250	-	-	-	80	-	M20	-	170	-	42	-
	4-12	800	160	950	966	-	-	1000	1120	1250	450	1420	250	737	617	487	120	100	M24	M24	210	210	50	50

Motor size	Poles	F	FA	G	GA	GB	GC	GD	GF	H	HA	HC	HD ¹⁾	HD ²⁾	HD ³⁾	HD	K	L	LC	LD	LD	O
													top-m.	top-m.	top-m.							
355 SM ₋	2	20	20	62.5	74.5	62.5	74.5	12	12	355	52	725	944	958	-	843	35	1409	1559	397	679	130
	4-12	28	25	90	106	81	95	16	14	355	52	725	944	958	-	843	35	1479	1659	467	750	130
355 ML ₋	2	20	20	62.5	74.5	62.5	74.5	12	12	355	52	725	944	958	-	843	35	1514	1664	397	732	130
	4-12	28	25	90	106	81	95	16	14	355	52	725	944	958	-	843	35	1584	1764	467	802	130
355 LK ₋₄₎	2	20	20	62.5	74.5	62.5	74.5	12	12	355	52	725	944	958	-	843	35	1764	1914	397	857	130
	4-12	28	25	90	106	81	95	16	14	355	52	725	944	958	-	843	35	1834	2014	467	927	130
400 L ₋	2	22	20	71	85	67.5	79.5	12	12	400	45	814	-	1045	-	943	35	1851	2001	458	909	150
	4-12	28	25	90	116	81	95	16	14	400	45	814	-	1045	-	943	35	1891	2071	498	949	150
400 LK ₋₄₎	2	22	20	71	85	67.5	79.5	14	12	400	45	814	-	1045	-	943	35	1851	2001	458	909	150
	4-12	28	25	90	106	81	95	16	14	400	45	814	-	1045	-	943	35	1891	2071	498	949	150
450 L ₋	2	22	-	71	85	-	-	14	-	450	46	933	-	1169	1231	-	42	2147	-	485	-	180
	4-12	32	28	109	127	100	116	18	16	450	46	933	-	1169	1231	-	42	2187	2407	525	-	180

Tolerances:

A, B	± 0,8	H	+0 -1.0
D, DA	ISO m6	N	ISO j6
F, FA	ISO h9	C, CA	± 0.8

- 1) Terminal box 370
- 2) Terminal box 750
- 3) Terminal box 1200
- 4) Size with alternative dimensions

Above table gives the main dimensions in mm.

For detailed drawings please see our web-pages 'www.abb.com/motors&drives' or contact us.

LV Process performance cast iron motors Sizes 355-450

Dimension drawings

Flange-mounted; IM B5 (IM 3001) , IM V1 (IM 3011), IM V3 (IM 3031), IM B14 (IM 3601), IM V18 (IM 3611) and IM V19 (IM 3631)

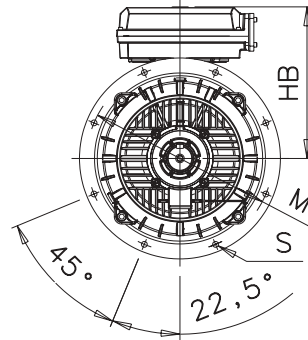
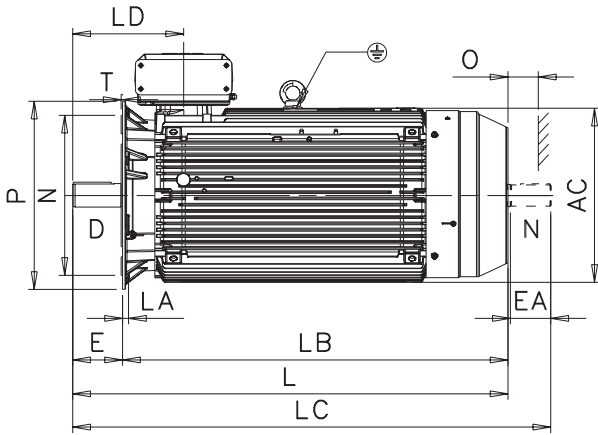

2

Motor size	Poles	AC	D	DA	DB	DC	E	EA	EG	EH	F	FA	G	GA	GB	GC	GD	GF
355 SM_	2	740	70	70	M20	M20	140	140	42	40	20	20	62.5	74.5	62.5	74.5	12	12
	4-12	740	100	90	M24	M24	210	170	51	51	28	25	90	106	81	95	16	14
355 ML_	2	740	70	70	M20	M20	140	140	42	40	20	20	62.5	74.5	62.5	74.5	12	12
	4-12	740	100	90	M24	M24	210	170	51	51	28	25	90	106	81	95	16	14
355 LK ⁴⁾	2	740	70	70	M20	M20	140	140	42	40	20	20	62.5	74.5	62.5	74.5	12	12
	4-12	740	100	90	M24	M24	210	170	51	51	28	25	90	106	81	95	16	14
400 L_	2	814	80	70	M20	M20	170	140	42	40	22	20	71	85	67.5	79.5	12	12
	4-12	814	110	90	M24	M24	210	170	50	50	28	25	100	116	81	95	16	14
400 LK ⁴⁾	2	814	80	70	M20	M20	170	140	42	40	22	20	71	85	67.5	79.5	12	12
	4-12	814	100	90	M24	M24	210	170	50	50	28	25	90	106	81	95	16	14
450 L_	2	966	80	-	M20	-	170	-	42	-	22	-	71	85	-	-	14	-
	4-12	966	120	100	M24	M24	210	210	50	50	32	28	109	127	100	116	18	16

Motor size	Poles	HB ¹⁾	HB ²⁾	HB ³⁾	L	LA	LB	LC	LD ¹⁾	LD ²⁾	LD ³⁾	M	N	O	P	S	T
355 SM_	2	589	603	-	1409	25	1269	1559	397	397	-	740	680	130	800	23	6
	4-12	589	603	-	1479	25	1269	1659	467	467	-	740	680	130	800	23	6
355 ML_	2	589	603	-	1514	25	1374	1664	397	397	-	740	680	130	800	23	6
	4-12	589	603	-	1584	25	1374	1764	467	467	-	740	680	130	800	23	6
355 LK ⁴⁾	2	589	603	-	1764	25	1624	1914	397	397	-	740	680	130	800	23	6
	4-12	589	603	-	1834	25	1624	2014	467	467	-	740	680	130	800	23	6
400 L_	2	-	645	-	1851	26	1681	2001	458	458	-	940	880	150	1000	28	6
	4-12	-	645	-	1891	26	1681	2071	498	498	-	940	880	150	1000	28	6
400 LK ⁴⁾	2	-	645	-	1851	26	1681	2001	458	458	-	740	680	150	800	24	6
	4-12	-	645	-	1891	26	1681	2071	498	498	-	740	680	150	800	24	6
450 L_	2	-	719	843	2147	33	1937	-	-	485	520	1080	1000	180	1150	28	6
	4-12	-	719	843	2187	33	1977	2407	-	525	560	1080	1000	180	1150	28	6

Tolerances:

D, DA ISO m6 N ISO js6 (315_)
F, FA ISO h9

- ¹⁾ Terminal box 370
- ²⁾ Terminal box 750
- ³⁾ Terminal box 1200
- ⁴⁾ Size with alternative dimensions

Above table gives the main dimensions in mm.

For detailed drawings please see our web-pages 'www.abb.com/motors&drives' or contact us.

LV Process performance cast iron motors Sizes 355-450

Dimension drawings

Foot- and flange-mounted: IM B35 (IM 2001), IM V15 (IM 2011), IM V36 (IM 2031)

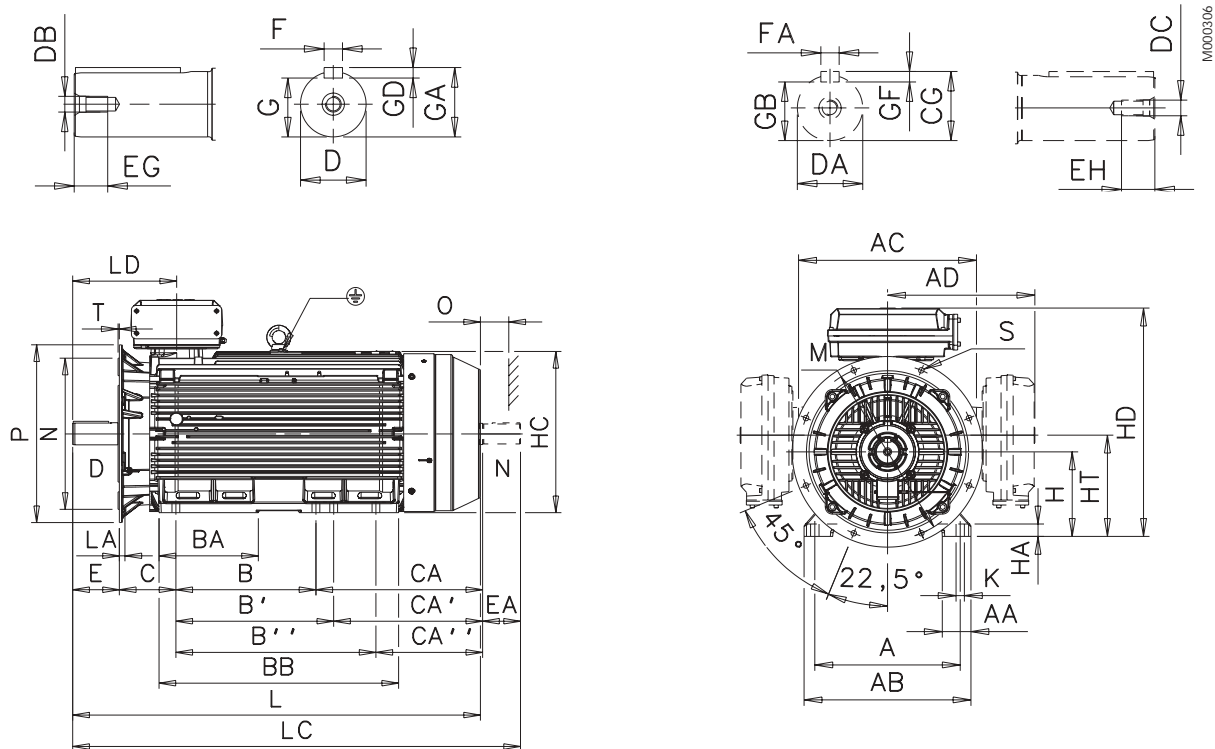

Motor size	Poles	A	AA	AB	AC	AD ¹⁾	AD ²⁾	B	B'	B''	BA	BB	C	CA	CA'	CA''	D	DA	DB	DC	E	EA	EG	EH	F	FA	G
355 SM ₋	2	610	120	700	746	604	618	500	560	-	221	722	254	525	465	-	70	70	M20	M20	140	140	42	40	20	20	62.5
	4-12	610	120	700	746	604	618	500	560	-	221	722	254	525	465	-	100	90	M24	M24	210	170	51	48	28	25	90
355 ML ₋	2	610	120	700	746	604	618	560	630	-	267	827	254	500	570	-	70	70	M20	M20	140	140	42	40	20	20	62.5
	4-12	610	120	700	746	604	618	560	630	-	267	827	254	500	570	-	100	90	M24	M24	210	170	51	48	28	25	90
355 LK ₋ ⁴⁾	2	610	120	700	746	604	618	630	710	900	447	1077	254	750	670	480	70	70	M20	M20	140	140	42	40	20	20	62.5
	4-12	610	120	700	746	604	618	630	710	900	447	1077	254	750	670	480	100	90	M24	M24	210	170	51	48	28	25	90
400 L ₋	2	710	150	840	834	-	660	900	1000	-	410	1156	224	567	467	-	80	70	M20	M20	170	140	42	40	22	20	71
	4-12	710	150	840	834	-	660	900	1000	-	410	1156	224	567	467	-	110	90	M24	M24	210	170	50	50	28	25	100
400 LK ₋ ⁴⁾	2	686	150	840	834	-	660	710	800	900	410	1156	280	701	611	511	80	70	M20	M20	170	140	42	40	22	20	71
	4-12	686	150	840	834	-	660	710	800	900	410	1156	280	701	611	511	100	90	M24	M24	210	170	50	50	28	25	90
450 L ₋	2	800	160	950	966	-	-	1000	1120	1250	450	1420	250	-	-	-	80	-	M20	-	170	-	-	-	22	-	71
	4-12	800	160	950	966	-	-	1000	1120	1250	450	1420	250	737	617	487	120	100	M24	M24	210	210	50	50	32	28	109

Motor size	Poles	GA	GB	GC	GD	GF	H	HA	HC	HD ¹⁾	HD ²⁾	HD ³⁾	HD	K	L	LA	LC	LD ¹⁾	LD ²⁾	LD ³⁾	LD	M	N	O	P	S	T
										top-	top-	top-	side-					top-	top-	top-	side-						
										m.	m.	m.	m.					m.	m.	m.	m.						
355 SM ₋	2	74.5	62.5	74.5	12	12	355	52	725	944	958	-	843	35	1409	25	1559	397	397	-	679	740	680	130	800	23	6
	4-12	106	81	95	16	14	355	52	725	944	958	-	843	35	1479	25	1659	467	467	-	750	740	680	130	800	23	6
355 ML ₋	2	74.5	62.5	74.5	12	12	355	52	725	944	958	-	843	35	1514	25	1664	397	397	-	732	740	680	130	800	23	6
	4-12	106	81	95	16	14	355	52	725	944	958	-	843	35	1584	25	1764	467	467	-	802	740	680	130	800	23	6
355 LK ₋ ⁴⁾	2	74.5	62.5	74.5	12	12	355	52	725	944	958	-	843	35	1764	25	1914	397	397	-	857	740	680	130	800	23	6
	4-12	106	81	95	16	14	355	52	725	944	958	-	843	35	1834	25	2014	467	467	-	927	740	680	130	800	23	6
400 L ₋	2	85	67.5	79.5	12	12	400	45	814	-	1045	-	943	35	1851	26	2001	458	458	-	909	940	880	150	1000	28	6
	4-12	116	81	95	16	14	400	45	814	-	1045	-	943	35	1891	26	2071	498	498	-	949	940	880	150	1000	28	6
400 LK ₋ ⁴⁾	2	85	67.5	79.5	12	12	400	45	814	-	1045	-	943	35	1851	26	2001	458	458	-	909	940	880	150	800	24	6
	4-12	106	81	95	16	14	400	45	814	-	1045	-	943	35	1891	26	2071	498	498	-	949	740	680	150	800	24	6
450 L ₋	2	85	-	-	14	-	450	46	933	-	1169	1293	-	42	2147	33	-	-	485	520	-	1080	1000	180	1150	28	6
	4-12	127	100	116	18	16	450	46	933	-	1169	1293	-	42	2187	33	2407	-	525	560	-	1080	1000	180	1150	28	6

Tolerances:

A, B	± 0,8	H	+0 -1.0
D, DA	ISO m6	N	ISO js6
F, FA	ISO h9	C	± 0,8

- 1) Terminal box 370
- 2) Terminal box 750
- 3) Terminal box 1200
- 4) Size with alternative dimensions

Above table gives the main dimensions in mm.

For detailed drawings please see our web-pages 'www.abb.com/motors&drives' or contact us.

Dimension drawings

LV Process performance cast iron motors

Terminal boxes, standard design with 6 terminals

Motor sizes 71 - 132

Motor sizes 160 - 250

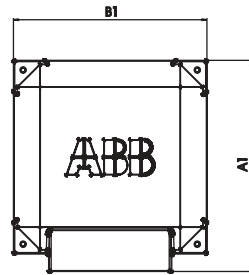
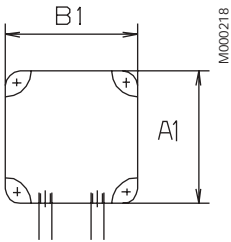

Motor size	A1	B1	H1
71 - 90	124	114	58
100 - 132	134	124	68
160 - 180	240	220	79.5
200 - 250	347.5	310	140.9

Motor sizes 280-315 Top- and side-mounted Terminal boxes 210, 370

Motor sizes 355-450 Top-mounted Terminal box 750 + adapter

Side-mounted Terminal box 750

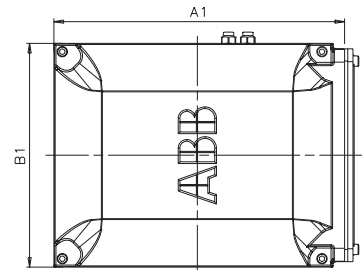
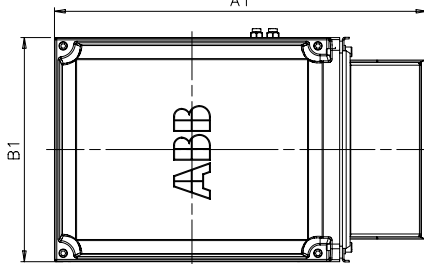
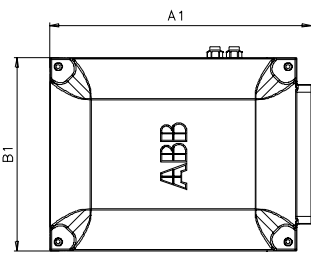
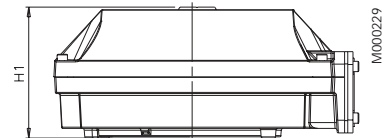
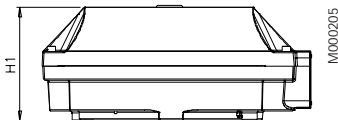

Motor sizes 450 Top-mounted Terminal box 1200

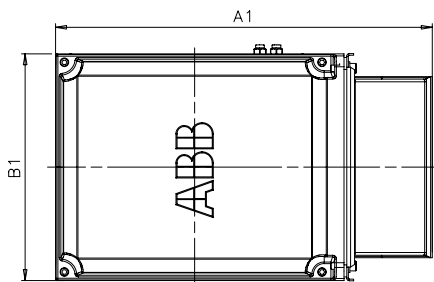
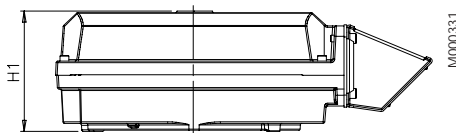

Motor sizes 280 - 400	A1	B1	H1
Terminal box type			
210	416	306	177
370	451	347	200
750 top-mounted	686	413	219
750 side-mounted	525	413	219
1200	1250	578	285
	1195	578	285
	1000	578	285

For motor dimensions please see dimension drawings on earlier pages or on our web-pages www.abb.com/motors&drives.

Accessories

Built-on-brake (variant code 412)

Brake design

Electromagnetic disc brakes are applied by the action of a set of springs and are released when voltage is applied to the brake coil.

This means that the motor will brake automatically in case of any voltage failure, as significant safety feature. The brake is always functional, irrespective of the mounting position of the brake motor.

Detailed view

1. Connection box, (with rectifier, optional)
2. Manual release (optional)
3. Modified N-end shield
4. V-ring seal
5. Adapter flange for brake
6. Brake
7. V-ring seal
8. Fan cover
9. Fan

Brake disc

The brake linings are made from asbestos-free material. The linings are highly resistant to wear and have excellent thermal conductivity, giving consistent performance across the temperature range.

The brake disc withstands large number of braking operations and is insensitive to dust and moisture.

Please note that changing between a used and a new disc will result in a different braking torque.

Replacing the brake disc

The brake disc must be replaced when reaching the minimum permissible lining thickness stated; please see the data provided by the brake manufacturer.

Rectifier

The rectifier is a device for DC brake applications. It is highly resistant to temperature as well as to voltage peaks, and it includes an additional protection of the auxiliary contact of contactor. With a compact design, it can be placed inside the motor terminal box. Since the rectifier is optional, please state this option when ordering if required.

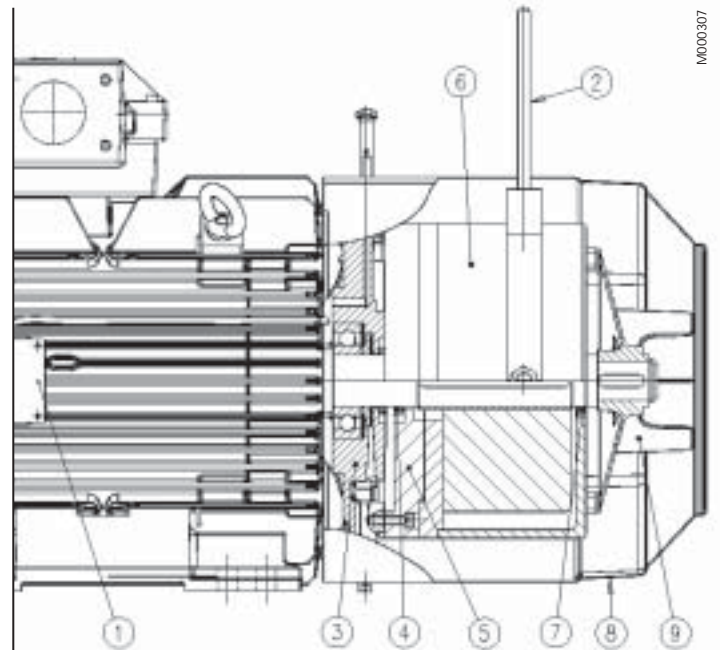

Torque adjustment

Reducing the torque of the brake is possible with most brake types, please see manufacturer's catalogue or contact ABB for more information.

Manual release

The manual release has two options, it either comes with screws (standard) or with a manual release. The manual release overrides the action of the brake springs as long as it is applied.

Manual release is an option available for all motor sizes, however it cannot be used in combination with the Pintsch Bamag brakes type SFB.

Brake rating plates

The same brake rating plates are used as for the standard M3BP motors i.e. stainless steel, with an additional marking of code 412, which stands for 'built-on-brake'.

Available brake types

The motors available in this section can be fitted with recommended brakes from either Pintsch Bamag or Stromag according to the table below; other brakes can be ordered on request.

**Pintsch & Bamag,
type KFB, IP 67, 110 V DC**
Electromagnetic Double-Disc
Spring-Applied Brake

Brake type	Brake torque Nm	For motor size
KFB 10	100	160
KFB 16	160	160 - 180
KFB 25	250	180 - 225
KFB 40	400	200 - 250
KFB 63	630	225 - 280
KFB 1000	1000	280 - 315
KFB 1600	1600	315 - 355
On request		355 - 450

**Pintsch & Bamag, type SFB, IP 67,
110 V DC**
Electromagnetic Double-Disc
Spring-Applied Brake

Brake type	Brake torque Nm	For motor size
SFB 16	160	200 - 225
SFB 25	250	200 - 250
SFB 40	400	225 - 250
SFB 63	630	250
SFB 100	1000	280 - 315
SFB 160	1600	315 - 355
SFB 250	2500	355 - 400
SFB 400	4000	400
On request		450

Stromag, type NFF, 110 V DC, IP66

Brake type	Brake torque Nm	For motor size
NFF 10	100	160
NFF 16	160	160 - 180
NFF 25	250	180 - 225
NFF 40	400	200 - 250
NFF 63	630	225 - 250

Options for the brake

On new manufacture only

- Hand release (not possible for Pintsch Bamag brake type SFB)
- Rectifier
- Micro switch
- Proximity switch (not possible for Stromag brake)
- Standstill heater

On request

- Special brake voltage
- Raised brake torque
- Combination with brake, separate cooling fan and/or tachometer

For other variants, please contact ABB.

Dimensions of brake motor

Foot-mounted:

IM B3 (IM1001), IM B6 (IM 1051),
M B7 (IM1061), IM B8 (IM 1071),
IM V5 (IM 1011), IM V6 (IM 1031)

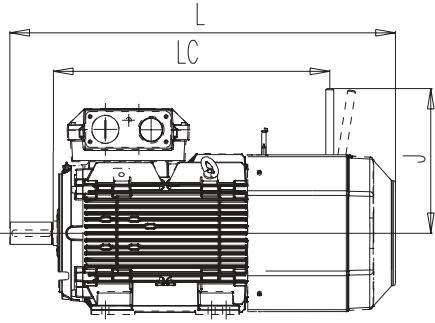

Flange-mounted:

IM B5 (IM 3001), IM V1 (IM 3011),
IM V3 (IM 3031), IM B14 (IM 3601),
IM V18 (IM 3611), IM V19 (IM 3631)

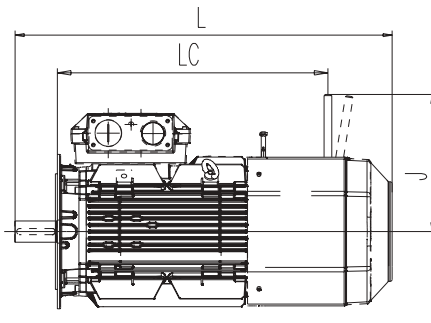

Foot- and flange-mounted:

IM B35 (IM 2001), IM V15 (IM 2011),
IM V36 (IM 2031)

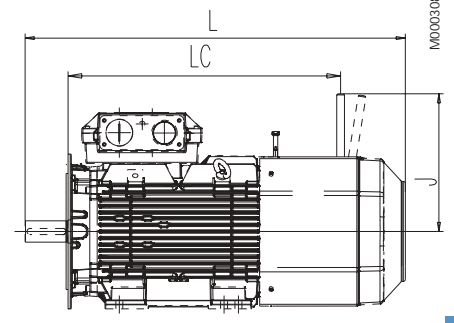

Motor size	Poles	Foot-mounted			Flange-mounted			Foot- and flange-mounted		
		L	LC	J	L	LC	J	L	LC	J
160	2-8	834	587	356	834	587	356	834	587	356
180	2-8	910	637	372	910	637	372	910	637	372
200 ML	2-8	994	684	432	994	684	432	994	684	432
225 SM	2	1071	754	460	1071	754	460	1071	754	460
225 SM	4-8	1101	754	460	1101	754	460	1101	754	460
250 SM	2-8	1110	761	460	1110	761	460	1110	761	460

Motor sizes 280 to 450 on request.

Other dimensions same as process performance cast iron motors sizes 180 to 250

Separate motor cooling (fan axial, N-end) for cast iron motors (183)

Main motor size	Fan motor type (at 50 Hz)	Product type	kW
M3BP 160 - 200	M2VA 71 B, 4 pole, B14	3GVA 072 002-B*C	0.37
M3BP 225 - 250	M2VA 80 A, 4 pole, B14	3GVA 082 001-B*C	0.55
M3BP 280 - 315 ML	M2VA 80 B, 4 pole, B14	3GVA 082 002-C*B	0.75
M3BP 315 LK - 355 SM	M2AA 90 L, 4 pole, B14	3GAA 092 002-C*E	1.5
M3BP 355 ML - 450 L	M2AA 100 LB, 4 pole, B14	3GAA 102 002-C*E	3.0

* = Voltage and frequency code

Separate motor cooling (fan top or side) for cast iron motors (422)

Main motor size	Fan motor type (at 50 Hz)	Product type	kW
M3BP 200	M2VA 71 B, 2 pole, B5	3GVA 071 002-B*B	0.55
M3BP 225 - 250	M2VA 80 B, 2 pole, B5	3GVA 081 002-B*B	1.1
M3BP 280 - 315	M2AA 90 L, 2 pole, B5	3GAA 091 002-B*E	2.2
M3BP 355 - 450 L	M2AA 100 L, 2 pole, B5	3GAA 101 001-B*E	3.0

* = Voltage and frequency code

Accessories

Protective roof and variable speed drives

Protective roof
Variant code 005

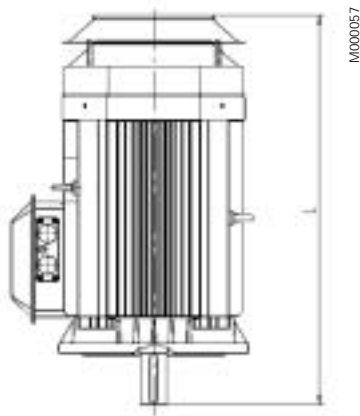

Tacho
Variant codes; 472, 473, 572 and 573

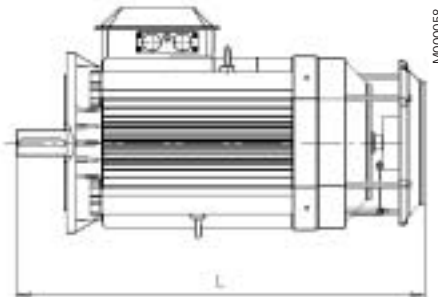

Separate cooling with or without tacho
Variant codes; 183, 474, 476, 477, 189, 574, 576 and 577

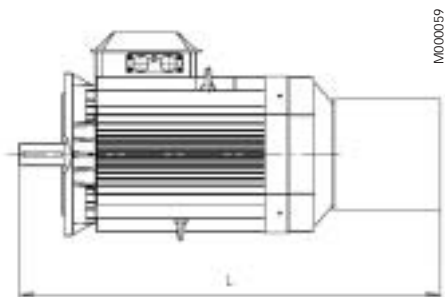

Variant codes;		005	183	189	472,473 572,573	474,476 477,574 576, 577
Motor size	Pole no	L	L	L	L	L
160 ¹⁾	2-8	654.5	1015.5	870.5	697	1015.5
160 ²⁾	2-8	695.5	1056.5	911.5	738	1056.5
180 ³⁾	2-8	732	1097	952	774	1097
180 ⁴⁾	2-8	752.5	1117.5	972.5	795	1117.5
200ML_	2-8	826.5	1234	1089	868	1234
225SM_	2	887	1295	1150	930	1295
	4-8	918	1325	1180	960	1325
250SM_	2-8	952	1346	1201	969	1346
280SM_	2	1190	1472	NA	1184	1620
	4-12	1190	1472	NA	1184	1620
315SM_	2	1290	1552	NA	1268	1708
	4-12	1320	1582	NA	1298	1738
315ML_	2	1400	1662	NA	1378	1820
	4-12	1430	1692	NA	1408	1850
315LK_	2	1561	1920	NA	1584	2054
	4-12	1591	1950	NA	1614	2084
355SM_	2	1513	1835	NA	1504	1963
	4-12	1583	1905	NA	1574	2033
355ML_	2	1618	1986	NA	1609	2119
	4-12	1688	2056	NA	1679	2189
355LK_	2	1881	2236	NA	1899	2409
	4-12	1951	2306	NA	1929	2439
400L/LK	2	1968	2313	NA	1946	2435
	4-12	2008	2353	NA	1986	2475
450L_	2	2362	2530	NA	2260	2530
	4-12	2402	2570	NA	2300	2570

¹⁾ M-2, MA-2, M-4, M-6, M-8, MA-8, L-2, L-4, L-6, MA-2/4, M-2/4, L-2/4, M-4/6, M-4/8, LB-2, LB-4

²⁾ L-8, L-4/6, L-4/8, LB-6, LB-8.

³⁾ M-2, M-4, L-6, L-8, M-2/4, M-4/6, M-4/8, LB-2.

⁴⁾ L-2/4, L-4/6, L-4/8, L-4, LB-4, LB-6, LB-8.

Accessories

Silencer for LV process performance cast iron motor sizes 280-450

Both foot-mounted and flange-mounted motors can be fitted with a silencer to reduce the noise level by about 10 dB(A). The silencer is painted blue and is made of 2 mm steel sheet. The sound absorbing material is 40 mm thick polyurethane foam. On the underside there is a rubber strip to seal against the floor. The silencer fits loosely over the motor.

Dimensions of silencers for foot-mounted motors

Silencers for flange-mounted motors on request.

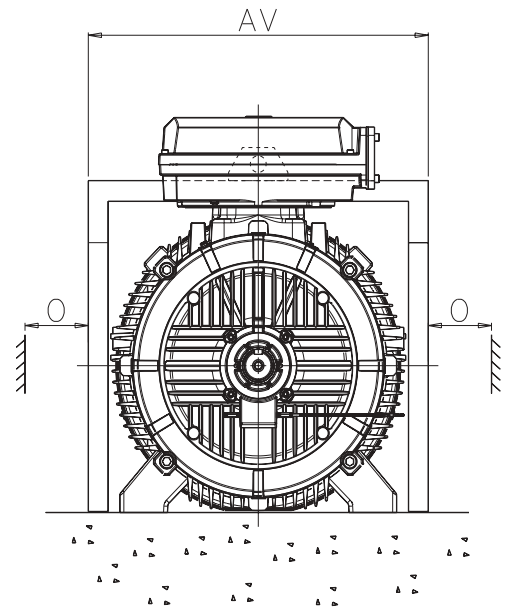
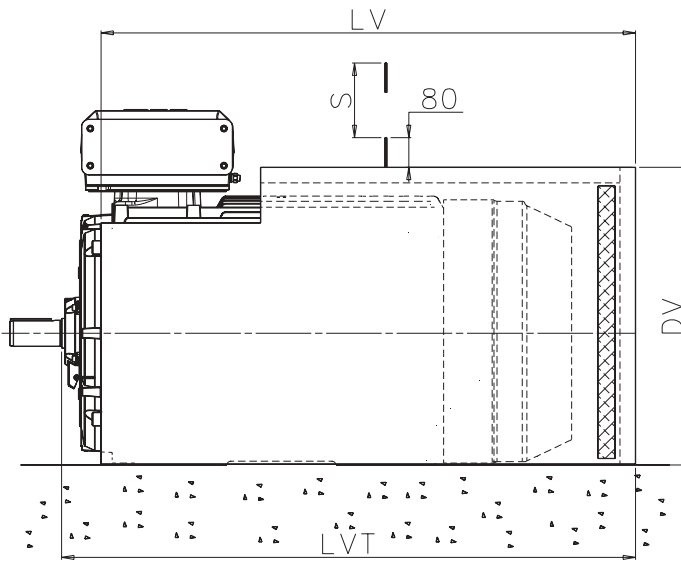

M000309



Motor size	AV	LV	LVT	DV	O ¹⁾	S ²⁾	Weight kg
280SM_	681	1010	1090	616	50	762	38
315 SM_	760	1094	1191	697	60	852	47
315 ML_	760	1205	1302	697	60	852	51
315 LK_	760	1411	1508	697	60	852	58
355 SM_	850	1335	1441	777	65	958	62
355 ML_	850	1440	1546	777	65	958	67
355 LK_	850	1690	1796	777	65	958	77
400 L_	938	1750	1873	866	75	1045	88
400 LK_	938	1750	1873	866	75	1045	88
450 L_	1050	2110	2230	990	80	1045	120

¹⁾ Clearance for motor cooling.

²⁾ Clearance for removal of silencer.

Note: Dimensions of silencers for smaller frame sizes on request.

Accessories

Slide rails for motor sizes 112 to 250

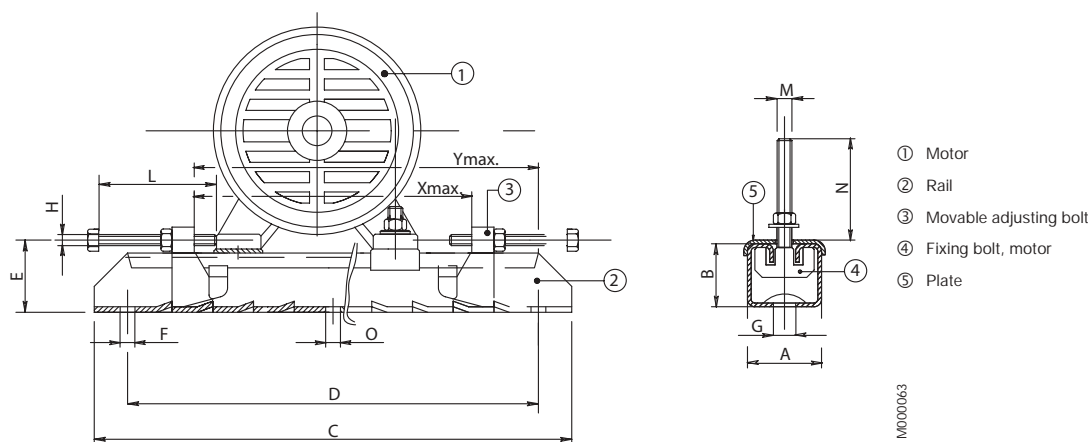

Motor size	Type	Product code 3GZV103001-															Weight kg
			A	B	C	D	E	F	G	H	L	M	N	O	Xmax	Ymax	
112-132	TT132/10	-12	65	40	530	480	52	17	26	M12	120	M10	45	-	360	420	7.8
160-180	TT180/12	-14	75	42	700	630	57	17	26	M12	120	M12	50	-	520	580	12.0
200-225	TT225/16	-15	82	50	864	800	68	17	27	M16	140	M16	65	17	670	740	20.4
250	TT280/20	-16	116	70	1072	1000	90	20	27	M18	150	M20	80	20	870	940	43.0

Each set includes two complete slide rails including screw for mounting the motor on the rails. Screws for mounting the rails on the foundation are not included. Slide rails are supplied with unmachined lower surfaces and should, prior to tightening down, be supported in a suitable manner.

Accessories

Slide rails for motor sizes 280 to 450

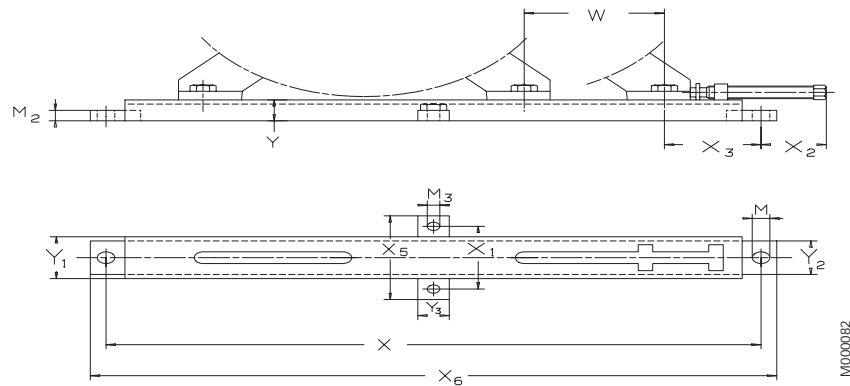

Type	Motor size	M	M2	M3	W	X	X1	X2	X3	X5	X6	Y	Y1	Y2	Y3	Weight/ rail kg
					max			max	min							
ZHKJ 50	280	28	25	20	135	850	150	125	135	200	900	50	100	80	50	14.5
ZHKJ 63	315	28	25	20	220	1040	150	125	150	200	1090	50	100	80	50	17.5
ZHKJ 71 ¹⁾	355	33	30	20	275	1260	190	145	185	240	1320	60	140	120	50	31.0
ZHKJ 71 ¹⁾	400	33	30	20	180	1260	190	140	200	240	1320	60	140	120	50	31.0
ZHKJ 90	450	28	30	28	260	1420	240	140	210	300	1480	70	180	158	60	61.0

¹⁾ When mounting on a ceiling or on a wall please contact the manufacturer.

Each set includes two complete slide rails including screw for mounting the motor on the rails. Screws for mounting the rails on the foundation are not included. Slide rails are supplied with unmachined lower surfaces and should, prior to tightening down, be supported in a suitable manner.

LV Process performance cast iron motor construction

Typical exploded view of cast iron motors, frame size 315

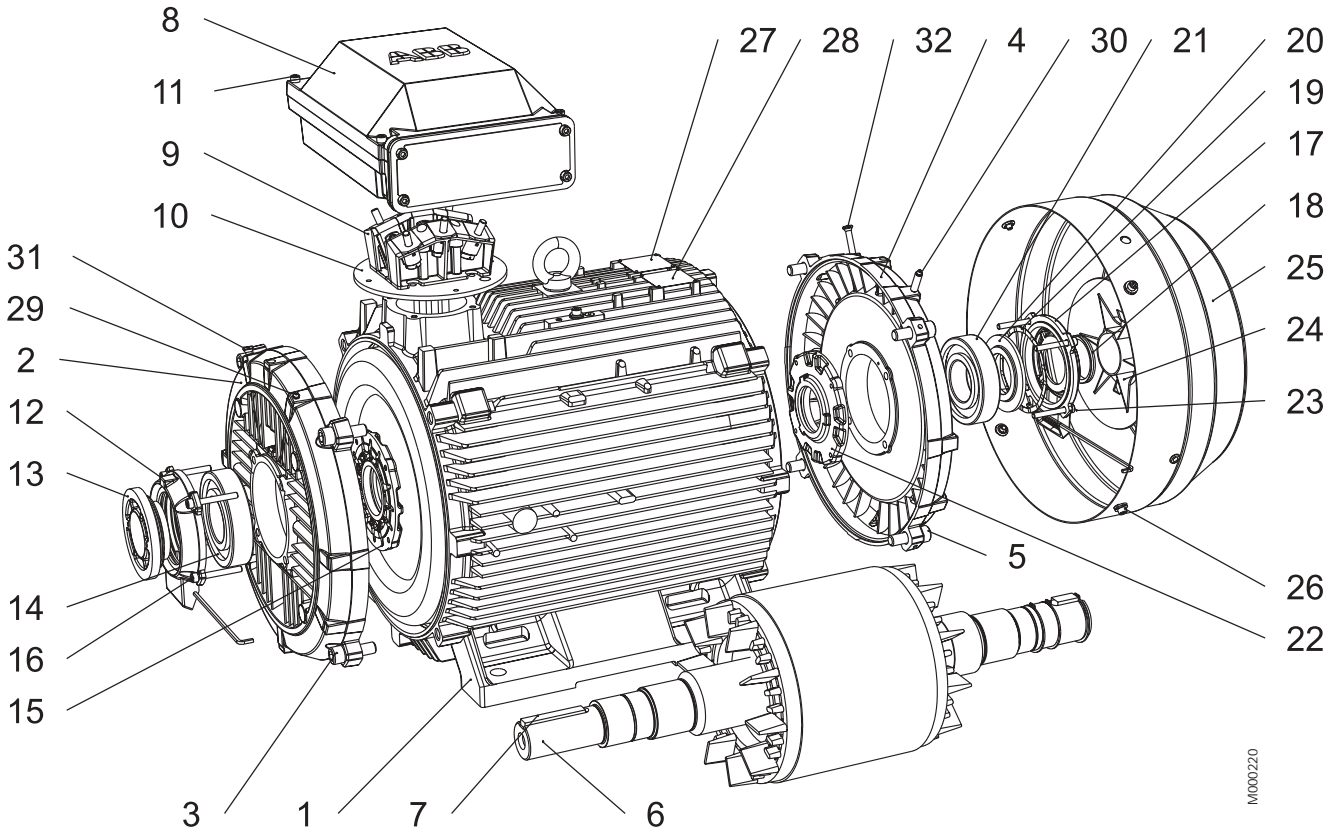

- | | | | |
|----|--|----|---------------------------------|
| 1 | Stator frame | 17 | Outer bearing cover, N-end |
| 2 | Endshield, D-end | 18 | Seal, N-end |
| 3 | Screws for endshield, D-end | 19 | Wave spring |
| 4 | Endshield, N-end | 20 | Valve disc, N-end |
| 5 | Screws for endshield, N-end | 21 | Bearing, N-end |
| 6 | Rotor with shaft | 22 | Inner bearing cover, N-end |
| 7 | Key, D-end | 23 | Screws for bearing cover, N-end |
| 8 | Terminal box | 24 | Fan |
| 9 | Terminal board | 25 | Fan cover |
| 10 | Intermediate flange | 26 | Screws for fan cover |
| 11 | Screws for terminal box cover | 27 | Rating plate |
| 12 | Outer bearing cover, D-end | 28 | Regreasing plate |
| 13 | Valve disc with labyrinth seal, D-end;
standard in 2-pole motors (V-ring in 4-8 pole) | 29 | Grease nipple, D-end |
| 14 | Bearing, D-end | 30 | Grease nipple, N-end |
| 15 | Inner bearing cover, D-end | 31 | SPM nipple, D-end |
| 16 | Screws for bearing cover, D-end | 32 | SPM nipple, N-end |

M000220

LV Process performance cast iron motors in brief, basic design

Motor size		71	80	90	100	112	132	160	180	
Stator	Material Paint colour shade	Cast iron EN-GJL-200/GG 20/GRS 200 Blue, Munsell 8B 4.5/3.25 / NCS 4822 B05G / RAL 5014								
	Paint thickness	Two-pack PUR-paint, thickness $\geq 60 \mu\text{m}$						Two-pack epoxy paint, thickness $\geq 70 \mu\text{m}$		
Bearing end shields	Material Paint colour shade	Cast iron EN-GJL-150/GG 15/GRS 150 Blue, Munsell 8B 4.5/3.25 / NCS 4822 B05G / RAL 5014				Cast iron EN-GJL-150/GG 15/GRS 150, flange end shields GJL-200				
	Paint thickness	Two-pack PUR-paint, thickness $\geq 60 \mu\text{m}$						Two-pack epoxy paint, thickn. $\geq 70 \mu\text{m}$		
Bearings	D-end = N-end	6202 2RS C3	6204 2RS C3	6205 2RS C3	6206 2RS C3	6207 2RS C3	6208 2RS C3	6309/C3	6310/C3	
	N-end	6202 2RS C3	6204 2RS C3	6205 2RS C3	6206 2RS C3	6206 2RS C3	6207 2RS C3	6309/C3	6309/C3	
Axially-locked bearings	Inner bearing cover	As standard, locked at D-end								
Bearing seal		2RS-integral seals						Axial seal as standard, radial seal on request		
Lubrication		Greased for life						Regreasable bearings, regr.nipples M6x1		
SPM-nipples		-						As standard		
Rating plate	Material	Stainless steel 0.80 Cr 18 Ni9						Stainless steel, SS-EN 10088, 0.5mm		
Terminal box	Frame material Cover material Cover screws material	Cast iron EN-GJL-150/GG 15/GRS 150 Cast iron EN-GJL-150/GG 15/GRS 150 Steel 5G, coated with zinc and yellow cromated								
Connections	Cable entries	2xM16	2xM25	2xM25	2xM32	2xM32	2xM32	2xM40	2xM40	
	Terminals	6 terminals for connection with cable lugs (not included)								
	Cable glands	Available as option						Cable flanges as std, cable glands as option		
Fan	Material	Glass fibre reinforced plastic								
Fan cover	Material	Steel								
	Paint colour shade	Blue, Munsell 8B 4.5/3.25 / NCS 4822 B05G / RAL 5014								
	Paint thickness	Two-pack PUR-paint, thickness $\geq 60 \mu\text{m}$						Two-pack polyester powder paint, thickness $\geq 50 \mu\text{m}$		
Stator winding	Material	Copper								
	Insulation	Insulation class F								
	Winding protection	3 PTC thermistors as standard, 150°C								
Rotor winding	Material	Pressure die-cast aluminum								
Balancing method		Half key balancing as standard								
Key ways		Open key way						Closed key way		
Heating elements	On request	25 W	25 W	25 W	25 W	25 W	25 W	25 W	25 W	
Drain holes		Optional						Standard		
Enclosure		IP 55, higher protection on request								
Cooling method		IC 411								

LV Process performance cast iron motors in brief, basic design

Motor size		200	225	250	280	315	355	400	450
Stator	Material	Cast iron EN-GJL-200/GG 20/GRS 200							
	Paint colour shade	Blue, Munsell 8B 4.5/3.25 / NCS 4822 B05G / RAL 5014							
	Paint thickness	Two-pack epoxy paint, thickness $\geq 80 \mu\text{m}$							
Bearing end shields	Material	Cast iron EN-GJL-150/GG 15 GRS150, flange end shields GLJ-200			Cast iron EN-GJL200/GG20/GRS 200, EN-GLJ-250 /GG25/GRS 250, EN-GJS-400/GG40/GRP 400				
	Paint colour shade	Blue, Munsell 8B 4.5/3.25 / NCS 4822 B05G / RAL 5014							
	Paint thickness	Two-pack epoxy paint, thickness $\geq 80 \mu\text{m}$							
Bearings	D-end 2-pole 4-12 -pole	6312/C3	6313/C3	6315/C3	6316/C3 6316/C3	6316/C3 6319/C3	6316M/C3 6322/C3	6317M/C3 6324/C3	6317M/C3 6326M/C3
	N-end 2-pole 4-12 -pole	6310/C3	6312/C3	6313/C3	6316/C3 6316/C3	6316/C3 6316/C3	6316M/C3 6316/C3	6317M/C3 6319/C3	6317M/C3 6322/C3
Axially-locked bearings	Inner bearing cover	As standard, locked at D-end							
Bearing seals		Axial seal as standard, radial seal on request			V-ring or labyrinth seal as standard see table in page 19.				
Lubrication		Regreasable bearings, regreasing nipples M6x1			Regreasable bearings, regreasing nipples, M10x1				
Measuring nipples		As standard							
Rating plate	Material	Stainless steel, EN 10088, thickness 0.5 mm							
Terminal box	Frame material	Cast iron EN-GJL150/GG 15/GRS 150			Cast iron EN-GJL-250/GG 25/GRS 250				
	Cover material	Cast iron EN-GJL150/GG 15/GRS 150			Cast iron EN-GJL-250/GG 25/GRS 250				Steel
	Cover screws material	Steel 8.8, zinc electroplated and yellow chromated							
Connections	Cable-entries 2-, 4-pole 6-pole	2xM63	2xM63	2xM63	2xM63	*)2xM63	*)2xØ60/80 *)2xØ60	*)2xØ80 *)2xØ60/80	*)2xØ60/80
	Terminals	6 terminals for connection with cable lugs (not included)							
	Cable glands	Cable flanges as standard, cable glands as option			Cable glands included as standard				
Fan	Material	Glass fibre reinforced plastic			Glass fibre reinforced plastic or aluminum				
Fan cover	Material	Steel							
	Paint colour shade	Blue, Munsell 8B 4.5/3.25 / NCS 4822 B05G / RAL 5014							
	Paint thickness	Two-pack polyester powder paint, thickness $\geq 50 \mu\text{m}$			Two-pack epoxy polyester powder paint, thickness $\geq 80 \mu\text{m}$				
Stator winding	Material	Copper							
	Insulation	Insulation class F							
	Winding protection	3 PTC thermistors as standard, 150°C			3 PTC thermistors as standard, 155°C				
Rotor winding	Material	Pressure die-cast aluminum							
Balancing method		Half key balancing as standard							
Key way		Closed key way			Open key way				
Heating elements	On request	50 W	50 W	50 W	50 W	2x50 W	2x65 W	2x65 W	2x100 W
Drain holes		Standard, open on delivery							
Enclosure		IP 55, higher protection on request							
Cooling method		IC 411							

*) For detailed information of connections, please see page 16.



Low Voltage Process Performance Aluminum Motors

Totally enclosed squirrel cage three phase low voltage motors,
Sizes 112 - 280, 4 to 90 kW



www.abb.com/motors&drives

- > Motors
- >> Low Voltage Motors
- >>> Process Performance Motors

Mechanical design	70
Rating plates	80
Ordering information.....	81
Technical data	82
Variant codes	96
Dimension drawings.....	102
Accessories	114
Aluminum motors in brief	116

General description

The process performance aluminum motors are developed in cooperation with customers from demanding industries, such as steel, mining and pulp & paper mills.

The following features are included as standard in the aluminum range:

- EFF 1
- Frame sizes 112 to 132 cast iron end shields in D-end and frame sizes 160 to 280 in both ends
- 63 size bearings

- Gamma ring at D-end 160 to 280
- SPM nipples from 160 to 280
- Stainless rating plate
- Metal fan cover
- Larger than standard terminal box from 200 to 280
- Wide temperature grease
- Grease nipples from 160 to 280
- Thermistors from 160 to 280

Mechanical design

Stator framework, bearing end shields in N-end, sizes 112 to 132 and feet are made of an extra corrosion resistant aluminum alloy with low copper content with the following exceptions:

Size 250, 2-pole and size 280 have feet made of cast iron. D-end bearing end shields sizes of 112 to 132 and bearing end shields of sizes 160 to 280 are made of cast iron.

3

Drain holes

Motors that will be operated in very humid or wet environments and especially under intermittent duty should be provided with drain holes. The appropriate IM designation, such as IM 3031, is specified on the basis of the method of mounting the motor.

Motors are provided with closable plastic plugs in the drain holes (see diagram below). The plugs will be open on delivery. When mounting the motors it should be ensured that the drain holes face downwards. In the case of vertical mounting, the upper plug must be

hammered home completely. In very dusty environments both plugs should be hammered home.

When mounting arrangement differs from foot mounted IM B3, please mention variant code 066 when ordering.

See variant codes 065 and 066 under the heading "Drain holes".

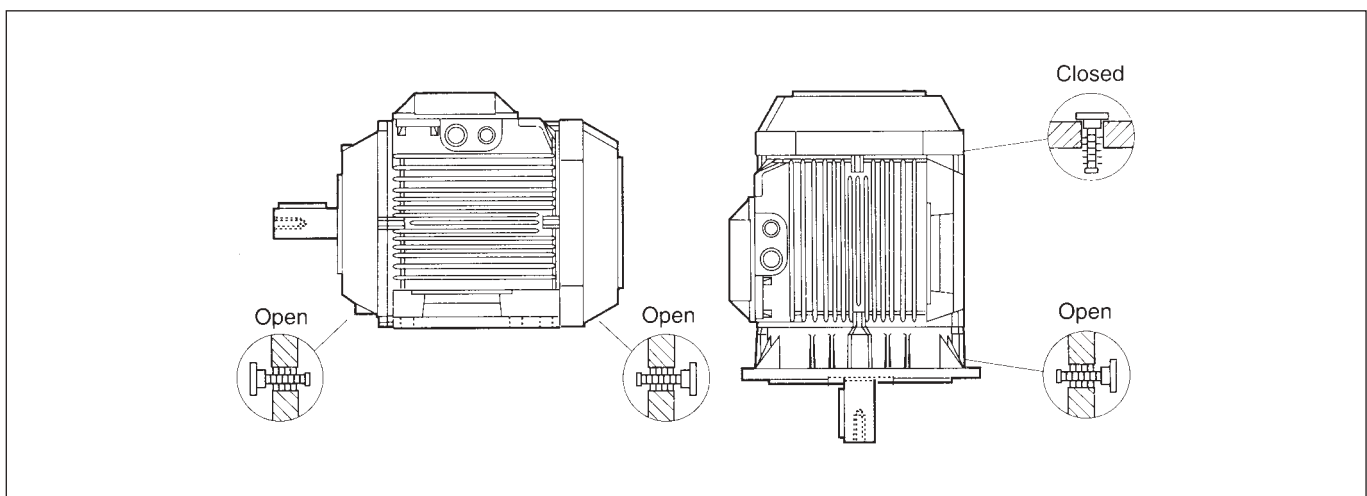

Terminal box

Sizes 112 to 180

The terminal box is made of aluminum alloy and is located on top of the stator. The lower part of the box is integrated with the stator. It is provided with two knockout openings on each side. Sizes 160-180 also have a third smaller opening. Cable glands are not included.

Sizes 200 to 280

The terminal box and cover are made of deep drawn steel and mounted on top of the stator. The box is bolted to the stator and is not rotatable. The size of the box is the same for all motors.

In the basic design the terminal box is provided with two FL 21 flange openings, one on each side. The opening on the right side, seen from the D-end, is supplied with a flange with two holes for M63 cable glands. On delivery the holes are sealed by means of plastic plugs. Cable glands are not supplied. The opening on the other side is provided with a cover flange.

When new motors are manufactured the terminal box can be mounted on the left or the right side. See variant codes 021 and 180 under the heading 0Terminal box0.

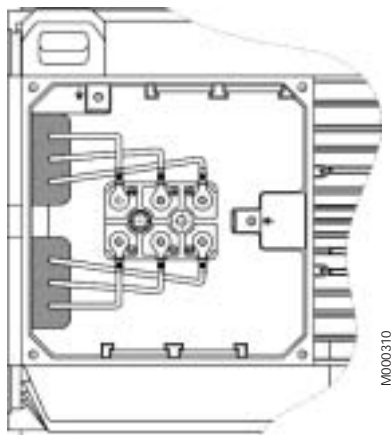

Terminal box size 112-180

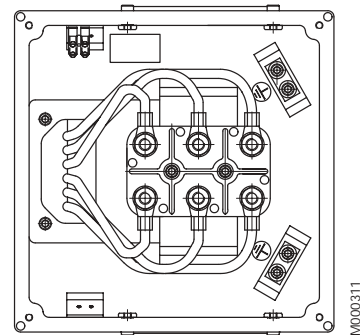

Terminal box size 200-280

Connections

The terminal block is provided with 6 terminals for connecting Cu-cable. The terminals are marked in accordance with IEC 60034-8.

Connection openings

Motor size	Opening	Metric cable entry	Method of connection	Terminal bolt size	Maximum connectable Cu-cable area, mm ²
112-132	Knock-out opening	2 x (M25 + M20)	Cable lug	M5	10
160-180	Knock-out opening	2 x (2 x M40 + M16)	Cable lug	M6	35
200-280	2 x FL 21	1 x (2 x M63 + M16)	Cable lug	M10	70

Bearings

The motors are provided with bearings according to the tables below.

Greater axial forces can be tolerated if the motors are provided with angular contact ball bearings. Note that in such cases the axial force must only operate in one direction.

Motor versions with roller bearings tolerate greater radial forces.

Basic version with deep groove ball bearings

Motor size	Foot- and flange-mounted motor	
	D-end	N-end
112 ¹⁾	6306-2Z/C3	6205-2Z/C3
112 ²⁾	6306-2Z/C3	6206-2Z/C3
132 ³⁾	6308-2Z/C3	6206-2Z/C3
132 ⁴⁾	6308-2Z/C3	6208-2Z/C3
160	6309/C3	6309/C3
180	6310/C3	6309/C3
200	6312/C3	6310/C3
225	6313/C3	6312/C3
250	6315/C3	6313/C3
280 2-pole	6315/C3	6313/C3
280 4-8 pole	6316/C3	6313/C3

¹⁾ M-6, M-8

²⁾ All 112 excl. ¹⁾

³⁾ SA-2, S-4, S-6, MA-6, MB-6, S-8, M-8

⁴⁾ All 132 excl. ³⁾

3 Alternative designs:

Version with roller bearings

It is recommended to use roller bearings in belt drives for motor sizes 160 - 280.

See variant code 037 under the heading 'Bearings and lubrication'.

Motor size	D-end	N-end
160	NU 309 ECP	Ø
180	NU 310 ECP	Ø
200	NU 312 ECP	Ø
225	NU 313 ECP	Ø
250	NU 315 ECP	Ø
280 2-pole	NU 315 ECP	Ø
280 4-8 pole	NU 316 ECP	Ø

Version with angular contact ball bearings

See variant codes 058 under the heading 'Bearings and lubrication'.

Motor size	D-end 058
160	7309 BE
180	7310 BE
200	7312 BE
225	7313 BE
250	7315 BE
280 2-pole	7315 BE
280 4-8 pole	7316 BE

Transport locking

Motors provided with roller bearings or angular contact ball bearings are fitted with a transport lock to prevent damage to the bearings, due to vibration, during transport.

Axially-locked bearings

The table below shows which of the motor's bearings are axially locked in the bearing seat. In motor sizes 112 to 280 the locking is done by an inner bearing cover.

See also variant code 042 under the heading 0Bearings and lubrication0.

Motor size	Foot-mounted motors	Flange-mounted motors	
		Large Range	Small Range
112-132	¹⁾	D-end	D-end
160-280	D-end	D-end	Ø

¹⁾ A spring-washer at the N-end presses the rotor toward the D-end.

Lubrication

The motors are delivered with bearing grease for use at normal temperatures in dry or humid environments.

The motors are lubricated for ambient temperatures 40°C and in some cases even above 40°C, see table 1 on the next page.

Motor sizes 112 to 180 are provided with shielded bearings. On request, motor sizes 112 to 180 are provided with grease nipples for regreasing, see variant code 041 under the heading 0Bearings and lubrications0.

Motor sizes 200-280 are provided with grease nipples for regreasing as standard.

The lubrication interval L_1 , suitable for relubricated bearings, is defined as the number of operating hours after which 99 per cent of the bearings are adequately lubricated.

Lubrication intervals and grease quantities are specified on a plate on the motor as well as in the installation, operation and maintenance manual supplied with the motor.

The grease lifetime L_{10} , suitable for permanent lubricated bearings, is defined as the number of operating hours after which 90 per cent of the bearings are adequately lubricated. 50 per cent of the bearings achieve two times this figure. Maximum lifetime, however, should be regarded as 40,000 hours.

In case of high ambient temperatures the shaft loads must be reduced compared to permissible loadings in the table (see page 76 and 77), please contact ABB.

See table on the next page regarding L_{10} lifetime.

Table 1: Grease lifetime L_{10} in deep groove ball bearings of type 2Z in horizontally mounted motors in continuous running duty.

Motor	r/min	Ambient temperature and rated output									
		25 °C		40 °C		50 °C		60 °C		70 °C	
		Basic	High	Basic	High	Basic	High	Basic	High	Basic	High
112	3000	40000	40000	40000	40000	40000	30000	26000	17000		
	1500				40000			27000			
	1000				35000			40000			
	750				35000			40000			
132	3000	40000	40000	40000	24000	40000		23000			
	1500				40000		22000		35000		
	1000				40000		30000	40000	35000		
	750				40000		40000		35000		
160	3000	40000	40000	40000	31000	26000	17000	14000	9000		
	1500				40000	40000	25000	37000			
	1000				40000	40000	25000	30000			
	750				40000	40000	30000	30000			
180	3000	40000	38000	38000	34000	34000	29000	20000	15000	10000	8000
	1500		40000	40000	38000	40000	20000	28000		15000	
	1000		40000	40000	40000	40000	40000	40000	20000	30000	
	750		40000	40000	40000	40000	30000	40000			

In vertically mounted motors, the grease lifetime is half the figures above.

For applications corresponding to the empty cells in the table, please contact ABB. These applications can imply reduced lifetime for bearings and winding.

Lubrication intervals

3 ABB follows the L1-principle in defining lubrication interval. That means that 99% of the motors are sure to make the interval time. The lubrication intervals can also be calculated according to the L10-principle, which are normally doubled compared to L1-values. Values available from ABB at request.

The table below gives lubrication intervals according to the L1-principle for different speeds. The values are valid for horizontal mounted motors (B3), with about 80°C bearing temperature and using high quality grease with lithium complex soap and mineral or PAO-oil.

For more information, see ABB's Low Voltage Motors Manual.

Frame size	Amount of grease g	3600 r/min	3000 r/min	1800 r/min	1500 r/min	1000 r/min	500-750 r/min
------------	--------------------	------------	------------	------------	------------	------------	---------------

Frame size	Amount of grease g	3600 r/min	3000 r/min	1800 r/min	1500 r/min	1000 r/min	500-750 r/min
------------	--------------------	------------	------------	------------	------------	------------	---------------

Ball bearings: lubrication intervals in duty hours

180	30	6000	8000	13500	16000	20000	23000
200	40	4000	6000	11000	13000	17000	21000
225	50	3000	5000	10000	12500	16500	20000
250	60	2500	4000	9000	11500	15000	18000
280	35	2000	3500	-	-	-	-
280	70	-	-	8000	10500	14000	17000

Roller bearings: lubrication intervals in duty hours

180	30	3000	4000	7000	8000	10000	11500
200	40	2000	3000	5500	6500	8500	10500
225	50	1500	2500	5000	6000	8000	10000
250	60	1300	2200	4500	5700	7500	9000
280	35	1000	1800	-	-	-	-
280	70	-	-	4000	5300	7000	8500

Permissible loading on shaft

Pulley diameter

When the desired bearing life has been determined the minimum permissible pulley diameter can be calculated with FR (or FRX), according to the formula:

$$D = \frac{1.9 \times 10^7 \times K \times P}{n \times F_R(X)}$$

where:

- D = diameter of pulley, mm
- P = power requirement, kW
- n = motor speed, r/min.
- K = belt tension factor, dependent on belt type and type of duty. A common value for V-belts is K = 2.5
- F_R = permissible radial force

Bearing life

The nominal life is defined as the number of hours that are attained or exceeded by 90% of identical bearings, in a large test series, under certain specified conditions.

The life of bearings is dependent on various factors such as bearing load, motor speed, operating temperature and the purity of the grease. The permissible radial and axial loading for different motor sizes is shown in the table on the following pages.

The table is valid for 50 Hz. For 60 Hz and/or some other bearing life than specified in the table the values are changed according to the table on the right.

The table values assume the occurrence of only radial (FR) or axial (FA) forces. In the case of simultaneous radial and axial forces information can be supplied on request. It is assumed that the radial force, FR, is applied at the end of the motor shaft.

Permissible force at changed bearing life or supply frequency

Bearing life in hours at		Permissible force, as percentage of value in table on the following pages
50 Hz	60 Hz	
25,000	21,000	100% of value for 25,000 hours
40,000	33,000	100% of value for 40,000 hours
63,000	52,000	86% of value for 40,000 hours
80,000	67,000	80% of value for 40,000 hours

Permissible radial forces

The tables on the following pages show the permissible radial force in Newton assuming zero axial force.

Permissible loads of simultaneous radial and axial forces will be supplied on request.

The bearing life, L₁₀, is calculated according to SKF's new theory on bearing life L_{10_{aah}}, which also takes the purity of the grease into consideration.

If the radial force is applied between points X₀ and X_{max}, the permissible force F_R can be calculated from the following formula:

$$F_R = F_{X0} - \frac{X}{E} (F_{X0} - F_{Xmax})$$

E = length of shaft extension in basic version.

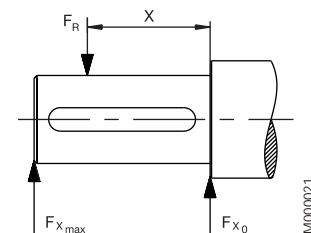

Permissible radial forces Motor sizes 112 to 280

Motor size	Poles	Length shaft extension E (mm)	Ball bearings Basic design with deep groove bearings				Roller bearings Alternative design with roller bearings			
			25,000 hours		40,000 hours		25,000 hours		40,000 hours	
			F_{x0} (N)	F_{xmax} (N)	F_{x0} (N)	F_{xmax} (N)	F_{x0} (N)	F_{xmax} (N)	F_{x0} (N)	F_{xmax} (N)
112M	2	60	2155	1700	2155	1700				
	4	60	2155	1700	2155	1700				
	6	60	2155	1700	2155	1700				
	8	60	2155	1700	2155	1700				
112MB	2	60	2098	1700	2098	1700				
	4	60	2098	1700	2098	1700				
	6	60	2098	1700	2098	1700				
	8	60	2098	1700	2098	1700				
132SA	2	80	4070	3180	3673	2870				
132SB	2	80	4057	3170	3673	2870				
132SC	2	80	3994	3200	3694	2960				
132S	4	80	4095	3200	3826	2990				
132M	4	80	4095	3200	3775	2950				
132MB	4	80	3994	3200	3744	3000				
132S	6	80	4095	3200	3993	3120				
132MA	6	80	4095	3200	3967	3100				
132MB	6	80	4095	3200	3929	3070				
132MC	6	80	3836	3200	3704	3090				
132S	8	80	4095	3200	4095	3200				
132M	8	80	4095	3200	4057	3170				
132MB	8	80	3994	3200	3994	3200				
160MA	2	110	4471	3500	4471	3500	4471	3500	4471	3500
	8	110	4471	3500	4471	3500	4471	3500	4471	3500
160M	2	110	4471	3500	4471	3500	4471	3500	4471	3500
	4	110	4471	3500	4471	3500	4471	3500	4471	3500
	6	110	4471	3500	4471	3500	4471	3500	4471	3500
	8	110	4471	3500	4471	3500	4471	3500	4471	3500
160L	2	110	4471	3500	4471	3500	4471	3500	4471	3500
	4	110	4471	3500	4471	3500	4471	3500	4471	3500
	6	110	4471	3500	4471	3500	4471	3500	4471	3500
	8	110	4380	3500	4380	3500	4380	3500	4380	3500
160LB	2	110	4471	3500	4471	3500	4471	3500	4471	3500
	4	110	4471	3500	4471	3500	4471	3500	4471	3500
	6	110	4380	3500	4380	3500	4380	3500	4380	3500
	8	110	4380	3500	4380	3500	4380	3500	4380	3500
180M	2	110	6903	5550	6356	5110	7338	5900	7338	5900
	4	110	7102	5710	6467	5200	7338	5900	7338	5900
180L	4	110	7052	5670	6405	5150	7338	5900	7338	5900
	6	110	7338	5900	6841	5500	7338	5900	7338	5900
	8	110	7338	5900	6928	5570	7338	5900	7338	5900
	8	110	7338	5900	6928	5570	7338	5900	7338	5900
180LB	2	110	6903	5550	6356	5110	7338	5900	7338	5900
	4	110	6993	5670	6352	5150	7277	5900	7277	5900
	6	110	7277	5900	6784	5500	7277	5900	7277	5900
	8	110	7277	5900	6870	5570	7277	5900	7277	5900

Permissible radial force - contd.

Motor size	Poles	Length shaft extension E (mm)	Ball bearings Basic design with deep groove ball bearings				Roller bearings Alternative design with roller bearings			
			25,000 hours		40,000 hours		25,000 hours		40,000 hours	
			F_{x0} (N)	F_{xmax} (N)	F_{x0} (N)	F_{xmax} (N)	F_{x0} (N)	F_{xmax} (N)	F_{x0} (N)	F_{xmax} (N)
200MLA	2	110	4942	4070	4371	3600	9459	7790	9459	7790
	4	110	5355	4410	4687	3860	9459	7790	9459	7790
	6	110	5586	4600	4845	3990	9459	7790	9459	7790
	8	110	5683	4680	4906	4040	9459	7790	9459	7790
200MLB	2	110	4930	4060	4359	3590	9459	7790	9459	7790
	4	110	5294	4360	4626	3810	9459	7790	9459	7790
	6	110	5513	4540	4784	3940	9459	7790	9459	7790
	8	110	5671	4670	4894	4030	9459	7790	9459	7790
200MLC	2	110	4918	4050	4359	3590	9459	7790	9459	7790
	6	110	5379	4430	4639	3820	9459	7790	9459	7790
225SMA	4	110	5825	4930	5104	4320	9807	8300	9807	8300
	8	110	6404	5420	5553	4700	9807	8300	9807	8300
225SMB	2	110	5395	4530	4776	4010	10600	8900	10600	8900
	4	110	5754	4870	5033	4260	9807	8300	9807	8300
	6	110	6002	5080	5199	4400	9807	8300	9807	8300
	8	110	6321	5350	5470	4630	9807	8300	9807	8300
225SMC	2	110	5371	4510	4752	3990	10600	8900	10600	8900
	4	110	5719	4840	4998	4230	9807	8300	9807	8300
	6	110	5931	5020	5128	4340	9807	8300	9807	8300
	8	110	6179	5230	5317	4500	9807	8300	9807	8300
250SMA	2	140	6973	5620	6179	4980	11291	9100	11291	9100
	4	140	7693	6200	6750	5440	14331	11550	14331	11550
	6	140	7978	6430	6936	5590	14331	11550	14331	11550
	8	140	8251	6650	7147	5760	14331	11550	14331	11550
250SMB	2	140	6961	5610	6154	4960	11291	9100	11291	9100
	4	140	7618	6140	6675	5380	14331	11550	14331	11550
	6	140	7941	6400	6899	5560	14331	11550	14331	11550
	8	140	8177	6590	7072	5700	14331	11550	14331	11550
280SMA	2	140	6646	5400	5846	4750	15262	12400	13785	11200
	4	140	7754	6300	6893	5600	18462	15000	16555	13450
	6	140	8809	7100	7755	6250	21093	17000	18860	15200
	8	140	8995	7250	7879	6350	21837	17600	19356	15600
280SMB	2	140	6462	5250	5723	4650	15262	12400	13785	11200
	4	140	7508	6100	6585	5350	17847	14500	16062	13050

Permissible axial forces

The following tables give the permissible axial forces in Newton, assuming zero radial force. The values are based on normal conditions at 50 Hz with standard bearings and calculated bearing lives of 20,000 and 40,000 hours.

At 60 Hz the values are to be reduced by 10%.

Permissible axial forces for mounting arrangement IM B3

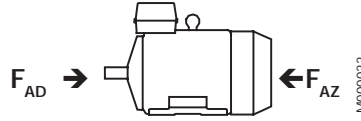

For two-speed motors, the values are to be based on the higher speed. The permissible loads of simultaneous radial and axial forces will be supplied on request

Given axial forces F_{AD} , assumes D-bearing locked by means of locking ring.

Ball bearings

Motor size	20,000 hours								40,000 hours							
	2-pole		4-pole		6-pole		8-pole		2-pole		4-pole		6-pole		8-pole	
	F_{AD} N	F_{AZ} N	F_{AD} N	F_{AZ} N	F_{AD} N	F_{AZ} N	F_{AD} N	F_{AZ} N	F_{AD} N	F_{AZ} N	F_{AD} N	F_{AZ} N	F_{AD} N	F_{AZ} N	F_{AD} N	F_{AZ} N
112M	2230	2230	2410	2410	2590	2590	2680	2680	1970	1970	2110	2110	2260	2260	2320	2320
112MB	2250	2250	2410	2410	2590	2590	2680	2680	1990	1990	2110	2110	2250	2250	2320	2320
132SA	3460	3460	-	-	-	-	-	-	3070	3070	-	-	-	-	-	-
132SB	3460	3460	-	-	-	-	-	-	3070	3070	-	-	-	-	-	-
132SC	3410	3410	-	-	-	-	-	-	3020	3020	-	-	-	-	-	-
132S	-	-	3770	3770	4020	4020	4150	4150	-	-	3320	3320	3520	3520	3610	3610
132M	-	-	3750	3750	-	-	4130	4130	-	-	3290	3290	-	-	3590	3590
132MA	-	-	-	-	4010	4010	-	-	-	-	-	-	3500	3500	-	-
132MB	-	-	3670	3670	3980	3980	4050	4050	-	-	3220	3220	3480	3480	3520	3520
132MC	-	-	-	-	3900	3900	-	-	-	-	-	-	3400	3400	-	-
160MA	4730	4730	-	-	-	-	5240	5240	4220	4220	-	-	-	-	4640	4640
160M	4730	4730	5230	5230	5220	5220	5220	5220	4220	4220	4640	4640	4630	4630	4630	4630
160L	5240	5240	5220	5220	5050	5050	4720	4720	4650	4650	4630	4630	4470	4470	4740	4740
160LB	5240	5240	5050	5050	4720	4720	4720	4720	4650	4650	4470	4470	4740	4740	4740	4740
180M	4660	4660	4950	4950	-	-	-	-	4250	4250	4500	4500	-	-	-	-
180L	-	-	4870	4870	5200	5200	5370	5370	-	-	4390	4390	4710	4710	4850	4850
180LB	4660	4660	4870	4870	5200	5200	5370	5370	4250	4250	4390	4390	4710	4710	4850	4850
200MLA	3050	3050	3850	3850	4400	4400	4850	4850	2430	2430	3050	3050	3500	3500	3850	3850
200MLB	3050	3050	3850	3850	4400	4400	4850	4850	2430	2430	3050	3050	3500	3500	3850	3850
200MLC	3050	3050	-	-	4400	4400	-	-	2430	2430	-	-	3500	3500	-	-
225SMA	-	-	4340	4340	-	-	5460	5460	-	-	3440	3440	-	-	4340	4340
225SMB	3440	3440	4340	4340	4960	4960	5460	5460	2370	2370	3440	3440	3940	3940	4340	4340
225SMC	3440	3440	4340	4340	4960	4960	5460	5460	2370	2370	3440	3440	3940	3940	4340	4340
250SMA	4180	4180	5260	5260	6020	6020	6630	6630	3320	3320	4180	4180	4780	4780	5260	5260
250SMB	4180	4180	5260	5260	6020	6020	6630	6630	3320	3320	4180	4180	4780	4780	5260	5260
280SMA	5000	5000	6200	6200	7100	7100	7350	7350	4500	4500	5400	5400	6250	6250	6500	6500
280SMB	5000	5000	6100	6100	-	-	-	-	4400	4400	5300	5300	-	-	-	-

Roller bearings

Motor size	20,000 hours								40,000 hours							
	2-pole		4-pole		6-pole		8-pole		2-pole		4-pole		6-pole		8-pole	
	F_{AD} N	F_{AZ} N	F_{AD} N	F_{AZ} N	F_{AD} N	F_{AZ} N	F_{AD} N	F_{AZ} N	F_{AD} N	F_{AZ} N	F_{AD} N	F_{AZ} N	F_{AD} N	F_{AZ} N	F_{AD} N	F_{AZ} N
160MA	3050	3050	-	-	-	-	3400	3400	2720	2720	-	-	-	-	3100	3100
160M	3060	3060	3370	3370	3330	3330	3330	3330	2710	2710	3000	3000	2970	2970	2970	2970
160L	3350	3350	3330	3330	3150	3150	3590	3590	2980	2980	2970	2970	2760	2760	3170	3170
160LB	3350	3350	3150	3150	3590	3590	3590	3590	2980	2980	2760	2760	3170	3170	3170	3170
180M	2820	2820	3120	3120	-	-	-	-	2420	2420	2660	2660	-	-	-	-
180L	-	-	3030	3030	3360	3360	3540	3540	-	-	2560	2560	2870	2870	3010	3010
180LB	2820	2820	3030	3030	3360	3360	3540	3540	2420	2420	2560	2560	2870	2870	3010	3010
200MLA	3050	3050	3850	3850	4400	4400	4850	4850	2430	2430	3050	3050	3500	3500	3850	3850
200MLB	3050	3050	3850	3850	4400	4400	4850	4850	2430	2430	3050	3050	3500	3500	3850	3850
200MLC	3050	3050	-	-	4400	4400	-	-	2430	2430	-	-	3500	3500	-	-
225SMA	-	-	4340	4340	-	-	5460	5460	-	-	3440	3440	-	-	4340	4340
225SMB	3440	3440	4340	4340	4960	4960	5460	5460	2370	2370	3440	3440	3940	3940	4340	4340
225SMC	3440	3440	4340	4340	4960	4960	5460	5460	2370	2370	3440	3440	3940	3940	4340	4340
250SMA	4180	4180	5260	5260	6020	6020	6630	6630	3320	3320	4180	4180	4780	4780	5260	5260
250SMB	4180	4180	5260	5260	6020	6020	6630	6630	3320	3320	4180	4180	4780	4780	5260	5260

Data for size 280 on request

Permissible axial forces for mounting arrangement IM V1

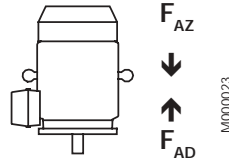

Ball bearings

Motor size	20,000 hours								40,000 hours							
	2-pole		4-pole		6-pole		8-pole		2-pole		4-pole		6-pole		8-pole	
	F _{AD} N	F _{AZ} N	F _{AD} N	F _{AZ} N	F _{AD} N	F _{AZ} N	F _{AD} N	F _{AZ} N	F _{AD} N	F _{AZ} N	F _{AD} N	F _{AZ} N	F _{AD} N	F _{AZ} N	F _{AD} N	F _{AZ} N
112M	2290	2170	2490	2330	2680	2510	2770	2590	2030	1910	2190	2030	2350	2180	2410	2230
112MB	2340	2170	2520	2300	2700	2480	2790	2570	2080	1910	2220	2000	2360	2140	2430	2210
132SA	3550	3370	-	-	-	-	-	-	3160	2980	-	-	-	-	-	-
132SB	3560	3360	-	-	-	-	-	-	3170	2970	-	-	-	-	-	-
132SC	3550	3270	-	-	-	-	-	-	3160	2880	-	-	-	-	-	-
132S	-	-	3910	3630	4160	3880	4320	3990	-	-	3460	3180	3660	3380	3780	3450
132M	-	-	3910	3590	-	-	4330	3930	-	-	3450	3130	-	-	3790	3390
132MB	-	-	3880	3460	4180	3780	4260	3840	-	-	3430	3010	3680	3280	3730	3310
132MA	-	-	-	-	4180	3850	-	-	-	-	-	-	3670	3340	-	-
132MC	-	-	-	-	4110	3690	-	-	-	-	-	-	3610	3190	-	-
160MA	4940	4520	-	-	-	-	5520	4960	4430	4010	-	-	-	-	4920	4360
160M	4960	4500	5500	4960	5540	4900	5540	4900	4450	3990	4910	4370	4950	4310	4950	4310
160L	5520	4960	5560	4880	5420	4680	5170	4280	4930	4370	4970	4290	4840	4100	5190	4300
160LB	5540	4940	5420	4680	5170	4280	5170	4280	4950	4350	4840	4100	5190	4100	5190	4300
180M	4990	4330	5400	4500	-	-	-	-	4580	3920	4950	4050	-	-	-	-
180L	-	-	5390	4350	5770	4630	5930	4810	-	-	4910	3870	5280	4140	5410	4290
180LB	5040	4280	5470	4270	5810	4590	5980	4770	4630	3870	4990	3790	5320	4100	5460	4240
200MLA	3600	2500	4580	3120	5280	3530	5270	3980	2970	1870	3780	2320	4370	2620	4270	2980
200MLB	3600	2500	4580	3120	5280	3530	5270	3980	2970	1870	3780	2320	4370	2620	4270	2980
200MLC	3600	2500	-	-	5280	3530	-	-	2970	1870	-	-	4370	2620	-	-
225SMA	-	-	5230	3440	-	-	6530	4400	-	-	4330	2550	-	-	5400	3270
225SMB	4140	2740	5230	3440	6030	3900	6530	4400	3430	2030	4330	2550	5010	2870	5400	3270
225SMC	4140	2740	5230	3440	6030	3900	6530	4400	3430	2030	4330	2550	5010	2870	5400	3270
250SMA	5020	3330	6380	4150	7440	4610	8050	5210	4160	2470	5290	3060	6200	3360	6680	3840
250SMB	5020	3330	6380	4150	7440	4610	8050	5210	4160	2470	5290	3060	6200	3360	6680	3840
280SMA	5950	4050	7380	5010	8540	5660	8810	5890	5450	3550	6580	4210	7690	4810	7960	5040
280SMB	5950	4050	7380	5010	-	-	-	-	5450	3550	6580	4210	-	-	-	-

3

Roller bearings

Motor size	20,000 hours								40,000 hours							
	2-pole		4-pole		6-pole		8-pole		2-pole		4-pole		6-pole		8-pole	
	F _{AD} N	F _{AZ} N	F _{AD} N	F _{AZ} N	F _{AD} N	F _{AZ} N	F _{AD} N	F _{AZ} N	F _{AD} N	F _{AZ} N	F _{AD} N	F _{AZ} N	F _{AD} N	F _{AZ} N	F _{AD} N	F _{AZ} N
160MA	3260	2840	-	-	-	-	3680	3120	2930	2510	-	-	-	-	3380	2820
160M	3290	2830	3640	3100	3650	3010	3650	3010	2940	2480	3270	2730	3290	2650	3290	2650
160L	3630	3070	3670	2990	3520	2780	4040	3150	3260	2700	3310	2630	3130	2390	3620	2730
160LB	3650	3050	3520	2780	4040	3150	4040	3150	3280	2680	3130	2390	3620	2730	3620	2730
180M	3150	2490	3570	2670	-	-	-	-	2750	2090	3110	2210	-	-	-	-
180L	-	-	3550	2510	3930	2790	4100	2980	-	-	3080	2040	3440	2300	3570	2450
180LB	3200	2440	3630	2430	3970	2750	4150	2930	2800	2040	3160	1960	3480	2260	3620	2400
200MLA	2090	1110	2390	1110	2570	1170	2650	1120	1850	870	2120	840	2290	890	2340	810
200MLB	2130	1010	2420	920	2590	1020	2660	900	1900	780	2150	650	2300	730	2350	590
200MLC	2140	981	-	-	2543	797	-	-	1909	751	-	-	2253	507	-	-
225SMA	-	-	3240	1740	-	-	3680	1900	-	-	2880	1380	-	-	3270	1490
225SMB	2900	1500	3250	1630	3260	1880	3690	1750	2590	1190	2880	1260	2860	1480	3280	1340
225SMC	2940	1410	3300	1420	3550	1370	3690	1470	2630	1100	2920	1040	3150	970	3270	1050
250SMA	3440	1800	3940	2000	4340	1870	4490	1980	3070	1430	3500	1560	3870	1400	4000	1490
250SMB	3510	1630	4040	1690	4410	1550	4530	1630	3150	1270	3590	1240	3930	1070	4020	1120

Data for size 280 on request

Rating plates

Single-speed motors of size 112 to 132 are stamped with 50 and 60 Hz at voltage code S and D. The current rating for each voltage range is specified on the rating plate. It represents the highest current that can exist within the voltage range at the rated output. The power factor and speed specified on the rating plate apply at 400 V 50 Hz and 460 V 60 Hz.

Single-speed motors of size 160 to 280 are stamped with 50 and 60 Hz at voltage code S and D. The rating plate is arranged in the form of a table with values for current, power factor and motor speed at six voltages.

Motor sizes 112 to 132

ABB		EFF I		CE	
3~Motor M3AP 132 M4		Cl,F		IP 55	
3G AA 132024-ADC +199		IEC 60034-1			
No.					
V	Hz	r/min	kW	A	cos φ
660-690	Y	50	1450	7,5	8,4
380-420	Δ	50	1450	7,5	14,6
440-480	Δ	60	1750	8,6	14,3
6308-2Z/C3		6208-2Z/C3		59 kg	

Motor sizes 160 to 280

ABB		EFF I		CE	
3~Motor M3AP 160 L 4		IEC 160 M/L 42			
No.					
		Ins.cl.F		IP55	
V	Hz	kW	r/min	A	cos φ
690	Y	50	15	1460	16.7
400	Δ	50	15	1460	29
660	Y	50	15	1455	17.3
380	Δ	50	15	1455	30
415	Δ	50	15	1465	28
440	Δ	60	18	1750	30
Prod.code 3GAA 162 102-ADC +199					
6309/C3		6209/C3		103 kg	
3GV 193 014-x		IEC 60034-1			

M000312

3

Ordering information

When placing an order, please state the following minimum data in the order, as in example.

The product code of the motor is composed in accordance with the following example.

Motor type	M3AP 112MB
Pole number	4
Mounting arrangement(IM code)	IM B3 (IM1001)
Rated output	5.5 kW
Product code	3GAA 112002-ADC 199
More variant codes if needed	

Motor size

A	B	C	D, E, F, G	
M3AP	112 MB	3GAA 112 002 -	ADC, 199 etc.	
		1 2 3 4 5 6 7 8 9 10 11 12 13 14...		
				A Motor type B Motor size C Product code D Code for mounting arrangement E Voltage and frequency code F Generation code followed by variant codes G Variant codes

Explanation of the product code

Positions 1 to 4

3GAA = Totally enclosed fan cooled squirrel cage motor with aluminum frame

Positions 5 and 6

IEC size

11 = 112	20 = 200
13 = 132	22 = 225
16 = 160	25 = 250
18 = 180	28 = 280

Position 7

Pole pairs

1 = 2 poles	5 = 10 poles
2 = 4 poles	6 = 12 poles
3 = 6 poles	7 > 12 poles
4 = 8 poles	8 = Two-speed motors
	9 = Multi-speed motors

Positions 8 to 10

Running number

Position 11

- (dash)

Position 12

Mounting arrangement

- A** = Foot-mounted motor
- B** = Flange-mounted motor.
Large flange with clearance holes.
- C** = Flange-mounted motor.
Small flange with tapped holes.
- F** = Foot- and flange-mounted motor.
Special flange.
- H** = Foot- and flange-mounted motor.
Large flange with clearance holes.
- J** = Foot- and flange-mounted motor.
Small flange with tapped holes.
- N** = Flange-mounted (CI ring flange FF)
- P** = Foot-and flange-mounted motor
(CI ring flange FF)
- V** = Flange-mounted motor. Special flange.

Position 13

Voltage and frequency: See tables below

Position 14

Version A,B,C... =

Generation code followed by variant codes

Code letters for supplementing the product code - single speed motors

Motor size	Code letter for voltage and frequency Direct start or, with Δ-connection, also Y/Δ-start									
	S		D		H	E	F	T	U	X
	50 Hz	60 Hz	50 Hz	60 Hz	50 Hz	50 Hz	50 Hz	50 Hz	50 Hz	
112-132	220-240 VΔ 380-420 VY	- 440-480 VY	380-420 VΔ 660-690 VY	440-480 VΔ -	415 VΔ	500 VΔ	500 VY	660 VΔ	690 VΔ	Other rated voltage, connection or frequency, 690 V max.
160-280	220, 230 VΔ 380,400,415 VY	- 440 VY	380,400,415VΔ 660, 690 VY	440 VΔ -	415 VΔ	500 VΔ	500 VY	660 VΔ	690 VΔ	

Code letters for supplementing the product code - two-speed motors

Motor size	Code letter for voltage and frequency						
	A	S	B	D	H	E	X
112-132	-	220-230 V	-	380-400 V	400-415 V	500 V	Other rated voltage or frequency, 690 V maximum
160-280	220 V	230 V	380 V	400 V	415 V	500 V	

LV Process performance aluminum motors

Technical data for totally enclosed squirrel cage three phase motors



IP 55 – IC 411 – Insulation class F, temperature rise class B

Output kW	Motor type	Product code	Speed r/min	Efficiency		Power factor cos φ 100%	Current		Torque			
				Full load 100%	3/4 load 75%		I _N A	I _s I _N	T _N Nm	T _s T _N	T _{max} T _N	
3000 r/min = 2-poles			400 V 50 Hz					Basic design				
4	¹⁾ M3AP 112 M	3GAA 111 022-¥¥C	2860	87.7	89.4	0.93	7.1	7.5	13.4	2.7	3.1	
5.5	¹⁾ M3AP 132 SA	3GAA 131 023-¥¥C	2900	88.6	89.6	0.88	10.3	9.7	18.1	3.8	4.3	
7.5	¹⁾ M3AP 132 SB	3GAA 131 024-¥¥C	2915	90.9	91.3	0.90	13.3	11.0	24.6	5.1	5.2	
11	¹⁾ M3AP 160 MA	3GAA 161 101-¥¥C	2930	91.0	91.2	0.88	20	6.2	36	2.1	2.8	
15	¹⁾ M3AP 160 M	3GAA 161 102-¥¥C	2920	91.3	91.7	0.90	26.5	6.4	49	2.3	2.7	
18.5	¹⁾ M3AP 160 L	3GAA 161 103-¥¥C	2920	92.4	93.1	0.91	32	7.2	61	2.6	2.9	
22	¹⁾ M3AP 180 M	3GAA 181 101-¥¥C	2930	92.8	93.3	0.89	38.5	7.2	71	2.7	3.0	
30	¹⁾ M3AP 200 MLA	3GAA 201 001-¥¥C	2955	93.2	93.2	0.88	53	8.5	97	2.9	3.1	
37	¹⁾ M3AP 200 MLB	3GAA 201 002-¥¥C	2950	93.6	93.7	0.89	64	7.2	120	2.3	2.9	
45	¹⁾ M3AP 225 SMB	3GAA 221 001-¥¥C	2960	94.1	93.9	0.88	79	7.7	145	2.5	2.9	
55	¹⁾ M3AP 250 SMA	3GAA 251 001-¥¥C	2970	94.2	93.8	0.89	95	7.9	177	2.4	3.0	
75	¹⁾ M3AP 280 SMA	3GAA 281 001-¥¥C	2970	95.1	95.2	0.90	127	8.2	241	2.4	3.1	
90	¹⁾²⁾ M3AP 280 SMB	3GAA 281 002-¥¥C	2970	95.4	94.8	0.90	152	8.3	290	2.7	3.4	
3000 r/min = 2-poles			400 V 50 Hz					High-output design				
5.5	¹⁾²⁾ M3AP 112 MB	3GAA 111 002-¥¥C	2855	86.6	87.9	0.93	9.9	7.3	18.4	2.6	3.4	
9.2	¹⁾²⁾ M3AP 132 SBB	3GAA 131 004-¥¥C	2840	86.8	88.3	0.92	16.8	8.5	31	3.3	3.6	
11	¹⁾²⁾ M3AP 132 SC	3GAA 131 003-¥¥C	2835	87.9	89.2	0.93	19.6	7.7	37	3.0	3.2	
22	¹⁾²⁾ M3AP 160 LB	3GAA 161 104-¥¥C	2920	92.0	93.0	0.91	38	6.9	72	2.3	2.9	
30	¹⁾ M3AP 180 LB	3GAA 181 102-¥¥C	2945	93.7	94.0	0.89	53	7.8	97	2.7	3.0	
45	¹⁾ M3AP 200 MLC	3GAA 201 003-¥¥C	2950	94.1	94.5	0.89	78	8.2	146	3.0	3.2	
55	¹⁾ M3AP 225 SMC	3GAA 221 002-¥¥C	2960	94.5	94.6	0.89	95	7.3	177	2.8	3.0	
55	¹⁾²⁾ M3AP 200 MLD	3GAA 201 004-¥¥C	2940	94.0	94.4	0.89	95	7.9	179	3.1	3.1	
80	¹⁾²⁾ M3AP 225 SMD	3GAA 221 003-¥¥C	2960	94.7	94.7	0.86	143	7.5	258	2.9	3.1	
75	¹⁾ M3AP 250 SMB	3GAA 251 002-¥¥C	2970	95.0	94.9	0.90	127	8.6	241	2.7	3.3	
95	¹⁾²⁾ M3AP 250 SMC	3GAA 251 003-¥¥C	2965	95.4	95.6	0.90	160	8.0	306	2.6	3.1	

¹⁾ When ordering, the following variant code has to be added to the product code:

199 = Extreme heavy duty design. Type designation M3AP

²⁾ Temperature rise class F.

³⁾ On request

The bullets in the product code indicate choice of mounting arrangement, voltage and frequency, generation code (see ordering information page).

LV Process performance aluminum motors

Technical data for totally enclosed squirrel cage three phase motors

IP 55 – IC 411 – Insulation class F, temperature rise class B

Output kW	Motor type	Speed r/min	Eficiency %	Power factor cos φ	Current I _N A	Speed r/min	Eficiency %	Power factor cos φ	Current I _N A	Moment of inertia J=1/4 GD ² kgm ²	Weight kg	Sound pressure level L _p dB(A)	
3000 r/min = 2-poles		380 V 50 Hz				415 V 50 Hz				Basic design			
4	¹⁾ M3AP 112 M	2860	86.7	0.93	7.6	2860	88.0	0.93	6.9	0.012	33	63	
5.5	¹⁾ M3AP 132 SA	2900	88.3	0.89	10.7	2900	88.7	0.86	10	0.016	42	69	
7.5	¹⁾ M3AP 132 SB	2915	90.5	0.90	13.8	2915	91.2	0.90	12.9	0.022	56	69	
11	¹⁾ M3AP 160 MA	2915	90.8	0.89	20.5	2935	91.0	0.86	19.4	0.039	81	69	
15	¹⁾ M3AP 160 M	2905	91.0	0.90	27.5	2925	91.4	0.89	25.5	0.047	92	69	
18.5	¹⁾ M3AP 160 L	2910	92.0	0.91	33.5	2930	92.6	0.90	31	0.053	102	69	
22	¹⁾ M3AP 180 M	2930	92.4	0.90	40.5	2945	93.0	0.88	37.5	0.077	128	69	
30	¹⁾ M3AP 200 MLA	2955	93.0	0.89	55	2960	93.3	0.86	52	0.15	192	72	
37	¹⁾ M3AP 200 MLB	2950	93.4	0.89	68	2955	93.7	0.87	63	0.18	217	72	
45	¹⁾ M3AP 225 SMB	2955	94.0	0.89	82	2965	94.2	0.87	77	0.26	257	74	
55	¹⁾ M3AP 250 SMA	2960	94.1	0.89	100	2970	94.2	0.88	92	0.49	311	75	
75	¹⁾ M3AP 280 SMA	2965	95.1	0.90	134	2970	95.2	0.89	123	0.57	350	75	
90	¹⁾²⁾ M3AP 280 SMB	2965	95.3	0.89	158	2970	95.4	0.91	148	0.59	404	75	
3000 r/min = 2-poles		380 V 50 Hz				415 V 50 Hz				High-output design			
5.5	¹⁾²⁾ M3AP 112 MB	2835	85.6	0.93	10.5	2865	87.2	0.92	9.5	0.012	33	63	
9.2	¹⁾²⁾ M3AP 132 SBB	2830	85.8	0.92	17.6	2850	87.4	0.93	16.2	0.02	50	69	
11	¹⁾²⁾ M3AP 132 SC	2815	87.0	0.93	21	2845	88.4	0.93	18.9	0.022	59	69	
22	¹⁾²⁾ M3AP 160 LB	2910	91.6	0.91	40	2925	92.4	0.90	37	0.058	108	69	
30	¹⁾ M3AP 180 LB	2940	93.9	0.90	55	2950	93.8	0.87	52	0.092	146	70	
45	¹⁾ M3AP 200 MLC	2945	94.0	0.89	82	2955	94.2	0.88	76	0.19	222	72	
55	¹⁾ M3AP 225 SMC	2950	94.3	0.89	100	2965	94.7	0.88	92	0.29	282	74	
55	³⁾ M3AP 200 MLD	³⁾	³⁾	³⁾	³⁾	³⁾	³⁾	³⁾	³⁾	0.2	232	³⁾	
80	¹⁾²⁾ M3AP 225 SMD	³⁾	³⁾	³⁾	³⁾	³⁾	³⁾	³⁾	³⁾	0.3	275	74	
75	¹⁾ M3AP 250 SMB	2965	94.7	0.90	134	2970	95.1	0.89	123	0.57	395	75	
95	¹⁾²⁾ M3AP 250 SMC	³⁾	³⁾	³⁾	³⁾	³⁾	³⁾	³⁾	³⁾	0.59	395	75	

3

Recalculation factors

Recalculation factors for current at rated voltages other than 400 V 50 Hz.

Rated voltage at 50 Hz and motor wound for	Recalculation factor	Rated voltage at 50 Hz and motor wound for	Recalculation factor
220 V	1.82	500 V	0.80
230 V	1.74	660 V	0.61
415 V	0.96	690 V	0.58

LV Process performance aluminum motors

Technical data for totally enclosed squirrel cage three phase motors



IP 55 – IC 411 – Insulation class F, temperature rise class B

Output kW	Motor type	Product code	Speed r/min	Efficiency		Power factor cos φ 100%	Current		Torque			
				Full load 100%	3/4 load 75%		I _N A	I _s I _N	T _N Nm	T _s T _N	T _{max} T _N	
1500 r/min = 4-poles			400 V 50 Hz				Basic design					
3	¹⁾ M3AP 112 MA	3GAA 112 021-¥¥C	1455	87.5	87.8	0.81	6.2	7.9	19.7	2.7	3.7	
4	¹⁾ M3AP 112 M	3GAA 112 022-¥¥C	1455	89.3	89.6	0.76	8.6	8.5	26.3	3.3	4.3	
5.5	¹⁾ M3AP 132 S	3GAA 132 023-¥¥C	1460	89.3	90.5	0.84	10.6	7.5	36	2.6	3.1	
7.5	¹⁾ M3AP 132 M	3GAA 132 024-¥¥C	1450	90.1	91.4	0.87	14	7.8	49	2.2	3.1	
11	¹⁾ M3AP 160 M	3GAA 162 101-¥¥C	1460	92.0	92.7	0.81	21.5	7.6	72	2.9	3.4	
15	¹⁾ M3AP 160 L	3GAA 162 102-¥¥C	1460	91.8	92.5	0.82	29	8.1	98	3.3	3.6	
18.5	¹⁾ M3AP 180 M	3GAA 182 101-¥¥C	1470	92.3	92.9	0.84	35	7.0	120	2.9	2.9	
22	¹⁾ M3AP 180 L	3GAA 182 102-¥¥C	1470	93.1	93.9	0.85	40	7.0	143	2.6	2.8	
30	¹⁾ M3AP 200 MLB	3GAA 202 001-¥¥C	1475	93.4	94.0	0.84	55	7.5	194	2.5	2.8	
37	¹⁾ M3AP 225 SMA	3GAA 222 001-¥¥C	1480	93.6	93.8	0.84	68	7.4	239	2.9	3.0	
45	¹⁾ M3AP 225 SMB	3GAA 222 002-¥¥C	1480	94.2	94.4	0.83	83	7.6	291	2.8	3.0	
55	¹⁾ M3AP 250 SMA	3GAA 252 001-¥¥C	1480	94.6	94.9	0.86	98	7.6	355	3.1	3.0	
75	¹⁾ M3AP 280 SMA	3GAA 282 001-¥¥C	1480	94.8	95.3	0.86	132	7.1	486	2.7	3.0	
90	¹⁾ M3AP 280 SMB	3GAA 282 002-¥¥C	1475	95.0	95.3	0.87	157	7.7	583	3.3	3.2	
1500 r/min = 4-poles			400 V 50 Hz				High-output design					
5.5	¹⁾²⁾ M3AP 112 MB	3GAA 112 002-¥¥C	1425	85.3	86.5	0.83	11.4	6.7	37	2.5	3.2	
9.2	¹⁾²⁾ M3AP 132 MBA	3GAA 132 004-¥¥C	1445	87.8	89.2	0.87	17.5	7.2	61	2.7	2.7	
11	¹⁾²⁾ M3AP 132 MB	3GAA 132 003-¥¥C	1450	88.6	89.9	0.86	21	7.4	73	2.5	2.7	
18.5	¹⁾²⁾ M3AP 160 LB	3GAA 162 103-¥¥C	1450	90.5	92.0	0.84	36	6.6	122	2.6	3.0	
30	¹⁾²⁾ M3AP 180 LB	3GAA 182 103-¥¥C	1465	92.5	93.3	0.84	56	6.8	196	2.5	2.8	
37	¹⁾ M3AP 200 MLB	3GAA 202 002-¥¥C	1475	93.8	94.2	0.84	68	7.4	240	2.9	2.7	
48	¹⁾²⁾ M3AP 200 MLC	3GAA 202 003-¥¥C	1470	93.6	94.1	0.84	89	8.1	311	4.4	3.2	
55	¹⁾ M3AP 225 SMC	3GAA 222 003-¥¥C	1480	94.6	95.0	0.84	100	7.5	356	3.5	3.0	
73	¹⁾²⁾ M3AP 225 SMD	3GAA 222 004-¥¥C	1475	94.2	94.5	0.85	132	8.1	473	3.9	3.2	
75	¹⁾ M3AP 250 SMB	3GAA 252 002-¥¥C	1480	94.6	95.1	0.86	132	6.9	486	2.6	3.0	
95	¹⁾²⁾ M3AP 250 SMC	3GAA 252 003-¥¥C	1475	94.5	95.3	0.88	165	7.3	616	2.6	3.1	

¹⁾ When ordering, the following variant code has to be added to the product code:

199 = Extreme heavy duty design. Type designation M3AP

²⁾ Temperature rise class F.

³⁾ On request.

The bullets in the product code indicate choice of mounting arrangement, voltage and frequency, generation code (see ordering information page).

LV Process performance aluminum motors

Technical data for totally enclosed squirrel cage three phase motors

IP 55 – IC 411 – Insulation class F, temperature rise class B

Output kW	Motor type	Speed r/min	EfP- ciency %	Power factor cos φ	Current I _N A	Speed r/min	EfP- ciency %	Power factor cos φ	Current I _N A	Moment of inertia J=1/4 GD ² kgm ²	Weight kg	Sound pressure level L _p dB(A)	
1500 r/min = 4-poles		380 V 50 Hz				415 V 50 Hz				Basic design			
3	¹⁾ M3AP 112 MA	1455	87.4	0.81	6.5	1455	87.8	0.80	6.1	0.018	34	56	
4	¹⁾ M3AP 112 M	1455	88.0	0.77	9	1455	89.0	0.77	8.2	0.018	34	56	
5.5	¹⁾ M3AP 132 S	1460	89.2	0.84	11	1460	89.4	0.84	10.3	0.038	48	59	
7.5	¹⁾ M3AP 132 M	1450	90.1	0.87	14.7	1450	90.2	0.87	13.5	0.048	59	59	
11	¹⁾ M3AP 160 M	1460	91.1	0.83	22.5	1470	91.6	0.82	20.5	0.091	107	62	
15	¹⁾ M3AP 160 L	1455	91.8	0.84	30	1465	91.9	0.81	28	0.102	111	62	
18.5	¹⁾ M3AP 180 M	1465	91.7	0.85	36	1470	92.2	0.83	34	0.161	133	62	
22	¹⁾ M3AP 180 L	1465	92.7	0.86	42	1475	93.3	0.84	38	0.225	171	63	
30	¹⁾ M3AP 200 MLB	1470	93.1	0.85	58	1475	93.5	0.84	54	0.34	222	63	
37	¹⁾ M3AP 225 SMA	1475	93.6	0.84	72	1480	93.8	0.81	68	0.37	237	66	
45	¹⁾ M3AP 225 SMB	1475	94.0	0.85	86	1480	94.2	0.81	82	0.42	252	66	
55	¹⁾ M3AP 250 SMA	1475	94.4	0.86	103	1480	94.5	0.84	96	0.72	301	67	
75	¹⁾ M3AP 280 SMA	1475	94.5	0.87	139	1480	94.8	0.86	128	0.88	394	67	
90	¹⁾ M3AP 280 SMB	1470	95.0	0.89	164	1475	95.1	0.87	153	0.95	419	67	
1500 r/min = 4-poles		380 V 50 Hz				415 V 50 Hz				High-output design			
5.5	¹⁾²⁾ M3AP 112 MB	1415	84.7	0.85	11.7	1430	85.5	0.79	11.4	0.018	36	56	
9.2	¹⁾²⁾ M3AP 132 MBA	1445	88.0	0.87	18.4	1445	88.3	0.87	16.8	0.048	59	59	
11	¹⁾²⁾ M3AP 132 MB	1445	88.2	0.87	22	1455	88.6	0.83	21	0.048	63	59	
18.5	¹⁾²⁾ M3AP 160 LB	1440	89.8	0.85	37	1450	90.8	0.83	34	0.102	111	63	
30	¹⁾²⁾ M3AP 180 LB	1465	92.2	0.85	58	1470	92.7	0.82	55	0.225	170	63	
37	¹⁾ M3AP 200 MLB	1475	93.5	0.85	71	1475	93.9	0.82	67	0.34	222	63	
48	¹⁾²⁾ M3AP 200 MLC	³⁾	³⁾	³⁾	³⁾	³⁾	³⁾	³⁾	³⁾	0.38	287	63	
55	¹⁾ M3AP 225 SMC	1475	94.3	0.84	105	1480	94.6	0.82	99	0.49	287	66	
73	¹⁾²⁾ M3AP 225 SMD	³⁾	³⁾	³⁾	³⁾	³⁾	³⁾	³⁾	³⁾	0.56	312	66	
75	¹⁾ M3AP 250 SMB	1475	94.3	0.87	139	1480	94.8	0.86	128	0.88	357	67	
95	¹⁾ M3AP 250 SMC	³⁾	³⁾	³⁾	³⁾	³⁾	³⁾	³⁾	³⁾	0.95	386	67	

3

Recalculation factors

Recalculation factors for current at rated voltages other than 400 V 50 Hz.

Rated voltage at 50 Hz and motor wound for	Recalculation factor	Rated voltage at 50 Hz and motor wound for	Recalculation factor
220 V	1.82	500 V	0.80
230 V	1.74	660 V	0.61
415 V	0.96	690 V	0.58

LV Process performance aluminum motors

Technical data for totally enclosed squirrel cage three phase motors

IP 55 – IC 411 – Insulation class F, temperature rise class B

Output kW	Motor type	Product code	Speed r/min	Efficiency		Power factor cos φ 100%	Current		Torque		
				Full load 100%	3/4 load 75%		I _N A	I _s I _N	T _N Nm	T _s T _N	T _{max} T _N
1000 r/min = 6-poles			400 V 50 Hz				Basic design				
2.2	¹⁾ M3AP 112 M	3GAA 113 001-¥¥C	940	80.5	81.0	0.74	5.4	5.6	22	2.1	2.7
3	¹⁾ M3AP 132 S	3GAA 133 001-¥¥C	960	84.5	84.8	0.75	6.9	6.5	30	2.1	3.0
4	¹⁾ M3AP 132 MA	3GAA 133 002-¥¥C	960	85.5	86.1	0.78	8.7	7.1	40	2.6	2.8
5.5	¹⁾ M3AP 132 MB	3GAA 133 003-¥¥C	955	86.0	87.0	0.78	11.9	6.6	55	2.1	2.8
7.5	¹⁾ M3AP 160 M	3GAA 163 101-¥¥C	970	89.3	90.4	0.79	15.4	6.6	74	1.9	2.6
11	¹⁾ M3AP 160 L	3GAA 163 102-¥¥C	970	89.8	90.5	0.78	23	6.9	109	2.1	3.4
15	¹⁾ M3AP 180 L	3GAA 183 101-¥¥C	970	90.8	91.5	0.78	31	6.8	147	2.0	3.3
18.5	¹⁾ M3AP 200 MLA	3GAA 203 001-¥¥C	985	91.1	91.7	0.81	36	7.0	180	2.7	2.5
22	¹⁾ M3AP 200 MLB	3GAA 203 002-¥¥C	980	91.7	92.2	0.81	43	6.8	214	2.9	3.0
30	¹⁾ M3AP 225 SMB	3GAA 223 001-¥¥C	985	92.8	93.0	0.83	56	7.2	291	3.1	2.9
37	¹⁾ M3AP 250 SMA	3GAA 253 001-¥¥C	985	93.4	93.7	0.83	69	7.3	358	3.1	2.8
45	¹⁾²⁾ M3AP 280 SMA	3GAA 283 001-¥¥C	985	93.4	93.7	0.84	83	7.2	436	3.2	2.8
1000 r/min = 6-poles			400 V 50 Hz				High-output design				
3	¹⁾²⁾ M3AP 112 MB	3GAA 113 002-¥¥C	935	80.0	81.2	0.76	7.2	5.5	31	2.5	2.7
6.3	¹⁾²⁾ M3AP 132 MC	3GAA 133 004-¥¥C	960	84.9	85.0	0.75	14.5	7.3	63	2.3	3.1
14	¹⁾²⁾ M3AP 160 LB	3GAA 163 103-¥¥C	960	89.8	90.1	0.77	29.5	7.0	138	2.5	3.1
18.5	¹⁾²⁾ M3AP 180 LB	3GAA 183 102-¥¥C	965	90.7	91.7	0.80	37	6.1	183	2.1	2.5
30	¹⁾²⁾ M3AP 200 MLC	3GAA 203 003-¥¥C	980	91.9	92.5	0.81	56	7.1	293	3.3	2.9
37	¹⁾ M3AP 225 SMC	3GAA 223 002-¥¥C	985	92.8	93.4	0.83	69	6.9	360	3.0	2.9
45	¹⁾²⁾ M3AP 250 SMB	3GAA 253 002-¥¥C	985	93.4	93.7	0.84	83	7.2	436	3.2	2.8

¹⁾ When ordering, the following variant code has to be added to the product code:

199 = Extreme heavy duty design. Type designation M3AP

²⁾ Temperature rise class F.

The bullets in the product code indicate choice of mounting arrangement, voltage and frequency, generation code (see ordering information page).

LV Process performance aluminum motors

Technical data for totally enclosed squirrel cage three phase motors

IP 55 – IC 411 – Insulation class F, temperature rise class B

Output kW	Motor type	Speed r/min	Eficiency %	Power factor cos φ	Current I _N A	Speed r/min	Eficiency %	Power factor cos φ	Current I _N A	Moment of inertia J=1/4 GD ² kgm ²	Weight kg	Sound pressure level L _p dB(A)	
1000 r/min = 6-poles		380 V 50 Hz				415 V 50 Hz				Basic design			
2.2	¹⁾ M3AP 112 M	930	80.0	0.78	5.4	950	80.5	0.71	5.4	0.015	27	54	
3	¹⁾ M3AP 132 S	955	84.0	0.77	7.1	965	84.0	0.72	6.9	0.031	39	61	
4	¹⁾ M3AP 132 MA	955	85.0	0.81	8.9	965	85.5	0.75	8.7	0.038	46	61	
5.5	¹⁾ M3AP 132 MB	950	85.5	0.81	12.2	960	86.0	0.76	11.8	0.045	54	61	
7.5	¹⁾ M3AP 160 M	960	88.7	0.80	16.1	970	89.6	0.77	15.1	0.089	96	59	
11	¹⁾ M3AP 160 L	960	89.4	0.80	23.5	970	90.0	0.76	22.5	0.107	110	59	
15	¹⁾ M3AP 180 L	970	90.9	0.79	32	975	91.1	0.74	30.5	0.217	160	59	
18.5	¹⁾ M3AP 200 MLA	980	90.8	0.81	38	985	91.1	0.78	36	0.37	182	63	
22	¹⁾ M3AP 200 MLB	980	91.6	0.81	45	985	91.8	0.79	42	0.43	202	63	
30	¹⁾ M3AP 225 SMB	985	92.6	0.83	59	985	92.9	0.82	55	0.64	247	63	
37	¹⁾ M3AP 250 SMA	985	93.3	0.84	72	990	93.5	0.81	67	1.16	306	63	
45	¹⁾²⁾ M3AP 280 SMA	985	93.5	0.84	87	985	93.6	0.83	81	1.49	389	63	
1000 r/min = 6-poles		380 V 50 Hz				415 V 50 Hz				High-output design			
3	¹⁾²⁾ M3AP 112 MB	925	79.5	0.79	7.3	940	80.0	0.73	7.2	0.018	33	54	
6.3	¹⁾²⁾ M3AP 132 MC	960	84.8	0.75	14.5	965	84.6	0.71	14.4	0.049	59	61	
14	¹⁾²⁾ M3AP 160 LB	955	89.7	0.79	30.5	965	89.6	0.75	29.5	0.127	125	62	
18.5	¹⁾²⁾ M3AP 180 LB	960	90.1	0.82	38	970	90.9	0.79	36	0.237	169	59	
30	¹⁾²⁾ M3AP 200 MLC	980	91.7	0.83	57	985	92.1	0.83	52	0.49	217	63	
37	¹⁾ M3AP 225 SMC	980	92.6	0.83	72	985	93.2	0.81	68	0.75	274	63	
45	¹⁾²⁾ M3AP 250 SMB	985	93.5	0.84	87	985	93.6	0.83	81	1.49	346	63	

3

Recalculation factors

Recalculation factors for current at rated voltages other than 400 V 50 Hz.			
Rated voltage at 50 Hz and motor wound for	Recalculation factor	Rated voltage at 50 Hz and motor wound for	Recalculation factor
220 V	1.82	500 V	0.80
230 V	1.74	660 V	0.61
415 V	0.96	690 V	0.58

LV Process performance aluminum motors

Technical data for totally enclosed squirrel cage three phase motors

IP 55 – IC 411 – Insulation class F, temperature rise class B

Output kW	Motor type	Product code	Speed r/min	Efficiency		Power factor cos φ 100%	Current		Torque			
				Full load 100%	3/4 load 75%		I _N A	I _s I _N	T _N Nm	T _s T _N	T _{max} T _N	
750 r/min = 8-poles			400 V 50 Hz				Basic design					
1.5	¹⁾ M3AP 112 M	3GAA 114 001-¥¥C	695	74.5	74.6	0.65	4.5	4.1	21	1.9	2.5	
2.2	¹⁾ M3AP 132 S	3GAA 134 001-¥¥C	720	80.5	80.2	0.67	5.9	5.3	29	1.9	2.5	
3	¹⁾ M3AP 132 M	3GAA 134 002-¥¥C	720	82.0	82.0	0.68	7.8	5.5	40	2.4	2.6	
4	¹⁾ M3AP 160 MA	3GAA 164 101-¥¥C	715	84.1	84.7	0.69	10	5.1	53	2.1	2.6	
5.5	¹⁾ M3AP 160 M	3GAA 164 102-¥¥C	710	84.7	85.6	0.70	13.4	5.5	74	2.4	2.6	
7.5	¹⁾ M3AP 160 L	3GAA 164 103-¥¥C	715	86.3	87.3	0.70	18.1	5.4	100	2.4	2.7	
11	¹⁾ M3AP 180 L	3GAA 184 101-¥¥C	720	89.6	90.3	0.76	23.5	5.7	146	2.1	2.5	
15	¹⁾ M3AP 200 MLA	3GAA 204 001-¥¥C	740	91.1	91.6	0.82	29	7.5	196	3.0	3.2	
18.5	¹⁾ M3AP 225 SMA	3GAA 224 001-¥¥C	730	91.1	91.6	0.79	37	6.8	242	2.8	3.1	
22	¹⁾ M3AP 225 SMB	3GAA 224 002-¥¥C	730	91.5	92.2	0.77	45	6.4	287	2.4	2.6	
30	¹⁾ M3AP 250 SMA	3GAA 254 001-¥¥C	735	92.8	93.1	0.79	59	7.3	389	2.2	2.6	
37	¹⁾ M3AP 280 SMA	3GAA 284 001-¥¥C	735	93.0	93.3	0.81	74	7.4	479	2.0	2.6	
750 r/min = 8-poles			400 V 50 Hz				High-output design					
1.9	^{1) 2)} M3AP 112 MB	3GAA 114 002-¥¥C	690	74.0	74.8	0.67	5.6	4.3	26.5	2.0	2.6	
3.8	^{1) 2)} M3AP 132 MB	3GAA 134 003-¥¥C	710	80.5	80.7	0.69	9.9	5.2	51	2.3	2.6	
8.5	^{1) 2)} M3AP 160 LB	3GAA 164 104-¥¥C	700	85.1	85.7	0.70	21	5.3	114	2.3	2.6	
15	^{1) 2)} M3AP 180 LB	3GAA 184 102-¥¥C	720	88.7	89.6	0.76	32.5	6.0	199	2.4	2.6	
18.5	¹⁾ M3AP 200 MLB	3GAA 204 002-¥¥C	735	91.4	91.8	0.81	36	7.3	241	2.6	3.1	
30	^{1) 2)} M3AP 225 SMC	3GAA 224 003-¥¥C	735	90.5	91.3	0.79	64	6.7	391	2.5	3.0	
37	¹⁾ M3AP 250 SMB	3GAA 254 002-¥¥C	735	93.0	93.3	0.81	74	7.4	479	2.0	2.6	

¹⁾ When ordering, the following variant code has to be added to the product code:

199 = Extreme heavy duty design. Type designation M3AP

²⁾ Temperature rise class F.

The bullets in the product code indicate choice of mounting arrangement, voltage and frequency, generation code (see ordering information page).

LV Process performance aluminum motors

Technical data for totally enclosed squirrel cage three phase motors

IP 55 – IC 411 – Insulation class F, temperature rise class B

Output kW	Motor type	Speed r/min	Eficiency %	Power factor cos φ	Current I _N A	Speed r/min	Eficiency %	Power factor cos φ	Current I _N A	Moment of inertia J=1/4 GD ² kgm ²	Weight kg	Sound pressure level L _p dB(A)	
750 r/min = 8-poles		380 V 50 Hz				415 V 50 Hz				Basic design			
1.5	¹⁾ M3AP 112 M	685	74.0	0.69	4.6	700	74.0	0.61	4.7	0.016	28	52	
2.2	¹⁾ M3AP 132 S	715	80.0	0.71	5.9	725	80.0	0.65	5.9	0.038	46	56	
3	¹⁾ M3AP 132 M	715	82.0	0.72	7.8	720	82.0	0.68	7.7	0.045	53	56	
4	¹⁾ M3AP 160 MA	710	83.5	0.71	10.2	720	84.1	0.66	9.9	0.072	83	59	
5.5	¹⁾ M3AP 160 M	705	84.0	0.72	13.8	715	85.0	0.68	13.3	0.091	96	59	
7.5	¹⁾ M3AP 160 L	710	85.7	0.72	18.6	715	86.6	0.68	17.8	0.131	126	59	
11	¹⁾ M3AP 180 L	715	89.0	0.77	24.5	720	89.8	0.75	23	0.224	156	59	
15	¹⁾ M3AP 200 MLA	735	91.0	0.83	30	740	91.2	0.79	29	0.45	192	60	
18.5	¹⁾ M3AP 225 SMA	730	91.0	0.79	39	735	91.3	0.76	36	0.61	232	63	
22	¹⁾ M3AP 225 SMB	730	91.0	0.81	47	735	91.7	0.76	44	0.68	247	63	
30	¹⁾ M3AP 250 SMA	735	92.6	0.81	61	740	92.7	0.77	58	1.25	308	63	
37	¹⁾ M3AP 280 SMA	735	92.5	0.82	77	735	92.8	0.81	73	1.52	389	63	
750 r/min = 8-poles		380 V 50 Hz				415 V 50 Hz				High-output design			
1.9	¹⁾²⁾ M3AP 112 MB	680	73.8	0.71	5.9	695	73.6	0.65	5.8	0.018	33	52	
3.8	¹⁾²⁾ M3AP 132 MB	705	80.0	0.72	10	715	80.5	0.67	9.9	0.049	59	56	
8.5	¹⁾²⁾ M3AP 160 LB	695	84.6	0.73	21.5	705	85.3	0.68	20.5	0.131	126	62	
15	¹⁾²⁾ M3AP 180 LB	715	88.1	0.78	33.5	720	89.1	0.74	32	0.24	164	62	
18.5	¹⁾ M3AP 200 MLB	735	91.2	0.83	37	735	91.6	0.79	35	0.54	217	60	
30	¹⁾²⁾ M3AP 225 SMC	730	90.4	0.80	65	735	90.9	0.77	63	0.8	277	63	
37	¹⁾ M3AP 250 SMB	735	92.5	0.82	77	735	92.8	0.81	73	1.52	346	63	

3

Recalculation factors

Recalculation factors for current at rated voltages other than 400 V 50 Hz.			
Rated voltage at 50 Hz and motor wound for	Recalculation factor	Rated voltage at 50 Hz and motor wound for	Recalculation factor
220 V	1.82	500 V	0.80
230 V	1.74	660 V	0.61
415 V	0.96	690 V	0.58

Data at voltage ranges

Rated data at voltage codes S and D



Single-speed motors of size 112 to 132 can be produced with voltage codes S and D, i.e., voltage range at both 50 and 60 Hz. The current rating for each voltage range is specified on the rating plate.

It represents the highest current that can exist within the voltage range at the rated output. The power factor and speed specified on the rating plate apply at the average voltage within the range.

Output in kW		Design ⁴⁾	Motor type	Product code 3GAA	Current in A ²⁾ at		Speed in r/min		Power factor cos φ	
50 Hz	60 Hz				380-420 V 50 Hz	440-480 V 60 Hz	380-420 V 50 Hz	440-480 V 60 Hz	380-420 V 50 Hz	440-480 V 60 Hz
3000/3600 r/min = 2 poles										
4	4.6		M3AP 112 M	111 022-¥¥C ¹⁾	7.6	7.4	2860	3460	0.93	0.93
5.5	6.4	³⁾ HO	M3AP 112 MB	111 002-¥¥C ¹⁾	10.5	10.4	2855	3455	0.93	0.93
5.5	6.4		M3AP 132 SA	131 023-¥¥C ¹⁾	10.7	10.7	2900	3500	0.88	0.87
7.5	8.6		M3AP 132 SB	131 024-¥¥C ¹⁾	13.9	13.8	2915	3515	0.90	0.89
9.2	10.6	³⁾ HO	M3AP 132 SBB	131 004-¥¥C ¹⁾	17.6	17.3	2840	3440	0.92	0.92
11	12.6	³⁾ HO	M3AP 132 SC	131 003-¥¥C ¹⁾	21	20	2835	3445	0.93	0.93
1500/1800 r/min = 4 poles										
3	3.5		M3AP 112 MA	112 021-¥¥C ¹⁾	6.5	6.4	1450	1750	0.81	0.8
4	4.6		M3AP 112 M	112 022-¥¥C ¹⁾	9	8.6	1455	1755	0.76	0.76
5.5	6.4	³⁾ HO	M3AP 112 MB	112 002-¥¥C ¹⁾	11.7	11.6	1425	1725	0.83	0.83
5.5	6.4		M3AP 132 S	132 023-¥¥C ¹⁾	11.1	11.1	1460	1760	0.84	0.84
7.5	8.6		M3AP 132 M	132 024-¥¥C ¹⁾	14.6	14.3	1450	1750	0.87	0.86
9.2	10.6	³⁾ HO	M3AP 132 MBA	132 004-¥¥C ¹⁾	18.4	18.2	1445	1745	0.87	0.87
11	12.6	³⁾ HO	M3AP 132 MB	132 003-¥¥C ¹⁾	22	22	1450	1750	0.86	0.86

¹⁾ When ordering, the following variant code has to be added to the product code:

199 = Extreme heavy duty design. Type designation M3AP

²⁾ Recalculation factors

Multiple by 1.73 when recalculating:

from 380-420 V to 220-240 V 50 Hz

from 440-480 V to 250-280 V 50 Hz

³⁾ Class F temperature rise

⁴⁾ High-output design.

Data at voltage ranges

Rated data at voltage codes S and D

Single-speed motors of size 112 to 132 can be produced with voltage codes S and D, i.e., voltage range at both 50 and 60 Hz. The current rating for each voltage range is specified on the rating plate.

It represents the highest current that can exist within the voltage range at the rated output. The power factor and speed specified on the rating plate apply at the average voltage within the range.

Output in kW		Design ³⁾	Motor type	Product code 3GAA	Current in A ²⁾ at		Speed in r/min		Power factor cos φ	
50 Hz	60 Hz				380-420 V 50 Hz	440-480 V 60 Hz	380-420 V 50 Hz	440-480 V 60 Hz	380-420 V 50 Hz	440-480 V 60 Hz
1000/1200 r/min = 6 poles										
2.2	2.5		M3AP 112 M	113 001-¥¥C ¹⁾	5.4	5.3	940	1140	0.74	0.74
3.0	3.5	HO	M3AP 112 MB	113 002-¥¥C ¹⁾	7.3	7.3	935	1135	0.76	0.75
3.0	3.5		M3AP 132 S	133 001-¥¥C ¹⁾	7.1	7.0	960	1160	0.75	0.75
4.0	4.6		M3AP 132 MA	133 002-¥¥C ¹⁾	8.9	8.9	960	1160	0.78	0.78
5.5	6.4		M3AP 132 MB	133 003-¥¥C ¹⁾	12.2	12.2	955	1155	0.78	0.78
6.5	7.5	HO	M3AP 132 MC	133 004-¥¥C ¹⁾	15.2	14.9	960	1160	0.75	0.76
750/900 r/min = 8 poles										
1.5	1.7		M3AP 112 M	114 001-¥¥C ¹⁾	4.6	4.4	695	845	0.65	0.65
2.0	2.3	HO	M3AP 112 MB	114 002-¥¥C ¹⁾	6	6	685	835	0.67	0.66
2.2	2.5		M3AP 132 S	134 001-¥¥C ¹⁾	5.9	5.9	720	870	0.67	0.66
3.0	3.5		M3AP 132 M	134 002-¥¥C ¹⁾	7.8	7.8	720	870	0.68	0.68
3.8	4.4	HO	M3AP 132 MB	134 003-¥¥C ¹⁾	10	10	710	860	0.69	0.69

¹⁾ When ordering, the following variant code has to be added to the product code:

199 = Extreme heavy duty design. Type designation M3AP

²⁾ Recalculation factors

Multiple by 1.73 when recalculating:

from 380-420 V to 220-240 V 50 Hz

from 440-480 V to 250-280 V 50 Hz

³⁾ High-output design.

LV Process performance aluminum motors

Technical data for totally enclosed squirrel cage three phase motors, two-speed

IP 55 – IC 411 – Insulation class F, temperature rise class F

Output kW	Motor type	Product code	Speed n r/min	Eff- ciency %	Power factor cos φ	Current		Torque			Moment of inertia J = Å GD ² kgm ²	Weight kg
						I _N A	I _s I _N	T Nm	T _s T _N	T _{max} T _N		
3000/1500 r/min = 2/4 poles			400 V 50 Hz			Fan drive, two separate windings						
3.5/0.6	M3AP 112 M	3GAA 118 204-¥¥C ¹⁾	2895/1470	83.0/68.0	0.92/0.60	6.6/2.1	7.0/5.8	11.5/3.9	1.7/1.8	2.3/2.8	0.012	32
5.5/1	M3AP 132 S	3GAA 138 207-¥¥C ¹⁾	2900/1470	84.0/64.0	0.88/0.65	10.8/3.5	7.8/5.7	18.1/6.5	2.4/2.0	2.9/2.8	0.016	42
7.4/1.2	M3AP 132 M	3GAA 138 208-¥¥C ¹⁾	2875/1475	85.0/67.0	0.93/0.64	13.5/4.1	7.5/5.9	24.6/7.8	2.1/2.0	2.6/2.8	0.022	56
13/1.9	M3AP 160 M	3GAA 168 352-¥¥C ¹⁾	2940/1470	88.5/79.5	0.92/0.79	23/4.4	7.8/6.4	42/12	2.1/2.1	3.0/2.5	0.054	100
17.5/2.5	M3AP 160 L	3GAA 168 353-¥¥C ¹⁾	2925/1475	89.0/81.0	0.92/0.77	31/5.8	7.1/6.7	57/16	2.0/2.5	2.6/2.9	0.057	107
20/2.8	M3AP 180 M	3GAA 188 357-¥¥C ¹⁾	2930/1465	89.0/77.0	0.90/0.77	36/6.9	6.4/5.8	65/18	2.1/1.9	2.4/2.0	0.094	141
25/3.6	M3AP 180 L	3GAA 188 358-¥¥C ¹⁾	2940/1465	90.0/78.0	0.88/0.78	46/8.6	7.5/7.3	81/24	2.6/1.9	2.9/1.9	0.108	161
30/4.1	M3AP 200 MLA	3GAA 208 210-¥¥C ¹⁾	2945/1480	91.5/85.0	0.89/0.72	54/10	8.0/7.1	97/26	2.2/2.7	2.8/2.8	0.15	192
38/5.5	M3AP 200 MLB	3GAA 208 211-¥¥C ¹⁾	2945/1480	92.5/86.5	0.91/0.74	67/13	7.7/6.8	123/35	2.2/2.6	2.6/2.6	0.19	222
43/6	M3AP 225 SMB	3GAA 228 207-¥¥C ¹⁾	2950/1475	92.5/86.5	0.90/0.78	75/13	7.1/5.8	139/39	2.3/2.7	2.4/2.0	0.26	257
50/7	M3AP 225 SMC	3GAA 228 208-¥¥C ¹⁾	2955/1480	93.0/87.5	0.91/0.78	86/15	7.3/6.1	162/45	2.4/2.9	2.4/2.1	0.29	282
70/10	M3AP 250 SMB	3GAA 258 204-¥¥C ¹⁾	2965/1485	94.0/89.5	0.90/0.76	119/22	9.3/7.1	225/64	2.3/2.5	3.1/2.3	0.57	330
3000/1500 r/min = 2-4 poles			400 V 50 Hz			Fan drive, Dahlander-connection						
4.5/1	M3AP 112 M	3GAA 118 104-¥¥C ¹⁾	2875/1450	83.0/80.0	0.93/0.76	8.4/2.4	7.0/6.0	14.9/6.6	1.8/1.9	2.3/2.8	0.012	32
6.2/1.3	M3AP 132 S	3GAA 138 127-¥¥C ¹⁾	2880/1455	84.0/80.0	0.91/0.67	11.8/3.5	7.0/6.5	20.6/8.5	2.0/2.6	2.6/3.3	0.016	42
8.3/1.7	M3AP 132 M	3GAA 138 108-¥¥C ¹⁾	2875/1455	84.0/82.0	0.93/0.71	15.4/4.2	7.4/6.6	27.6/11.2	2.5/2.7	2.7/3.3	0.022	56
10/2	M3AP 160 MA	3GAA 168 301-¥¥C ¹⁾	2910/1465	85.0/83.5	0.89/0.73	19/4.8	5.9/6.1	30/43	1.5/2.4	2.3/2.8	0.039	81
16/3.2	M3AP 160 M	3GAA 168 302-¥¥C ¹⁾	2915/1465	87.5/86.5	0.92/0.76	28.5/7	6.6/6.3	52/21	1.8/2.5	2.4/2.8	0.054	100
19.5/4.5	M3AP 160 L	3GAA 168 303-¥¥C ¹⁾	2930/1465	89.0/88.0	0.89/0.77	36/9.7	7.6/6.4	64/29	2.3/2.5	2.9/2.8	0.057	107
21.5/4.7	M3AP 180 M	3GAA 188 305-¥¥C ¹⁾	2935/1465	90.0/88.0	0.91/0.77	38/10	7.0/5.3	70/28	2.1/2.1	2.6/2.3	0.094	141
26/5.2	M3AP 180 L	3GAA 188 306-¥¥C ¹⁾	2940/1470	90.5/89.5	0.89/0.75	47/11	6.9/5.8	85/34	2.3/2.4	2.6/2.4	0.108	161
32/8	M3AP 200 MLA	3GAA 208 110-¥¥C ¹⁾	2940/1465	90.0/89.5	0.89/0.85	58/16	7.1/6.2	104/52	2.0/2.0	2.5/2.2	0.28	197
39/10	M3AP 200 MLB	3GAA 208 111-¥¥C ¹⁾	2950/1475	91.5/91.0	0.89/0.85	69/19	7.4/6.2	126/65	2.0/2.0	2.6/2.3	0.34	222
42/11	M3AP 200 MLC	3GAA 208 112-¥¥C ¹⁾	2950/1470	92.5/91.0	0.89/0.77	75/23	7.7/5.6	136/71	2.2/2.1	3.0/2.5	0.19	222
45/13	M3AP 225 SMB	3GAA 228 107-¥¥C ¹⁾	2955/1475	93.0/91.5	0.92/0.82	76/25	7.4/5.3	145/84	2.0/2.0	2.6/2.1	0.27	257
55/15	M3AP 225 SMC	3GAA 228 108-¥¥C ¹⁾	2955/1475	93.5/92.5	0.91/0.82	94/29	7.3/5.4	178/97	2.0/2.0	2.6/2.2	0.3	282
75/25	M3AP 250 SMB	3GAA 258 104-¥¥C ¹⁾	2965/1475	94.5/93.0	0.92/0.82	125/48	8.9/5.5	241/162	2.3/2.0	3.1/2.2	0.36	330

Data for motor size 280 on request.

¹⁾ When ordering, the following variant code has to be added to the product code:

199 = Extreme heavy duty design. Type designation M3AP

The bullets in the product code indicate choice of mounting arrangement, voltage and frequency generation code (see ordering information page).

LV Process performance aluminum motors

Technical data for totally enclosed squirrel cage three phase motors, two-speed

IP 55 – IC 411 – Insulation class F, temperature rise class F

Output kW	Motor type	Product code	Speed n r/min	Efficiency %	Power factor cos φ	Current		Torque			Moment of inertia J = Å GD ² kgm ²	Weight kg
						I _N A	I _s I _N	T Nm	T _s T _N	T _{max} T _N		
1500/1000 r/min = 4/6 poles			400 V 50 Hz			Fan drive, two separate windings						
3/1	M3AP 112 M	3GAA 118 205-¥¥C ¹⁾	1445/975	82.0/67.0	0.84/0.68	6.3/3.1	6.0/4.0	19.8/9.8	1.3/1.0	2.3/2.2	0.018	33
4.5/1.5	M3AP 132 S	3GAA 138 229-¥¥C ¹⁾	1460/985	83.0/67.0	0.85/0.64	9.2/5.1	6.5/4.2	29.4/14.5	1.5/1.0	2.3/2.2	0.038	48
6/2	M3AP 132 M	3GAA 138 230-¥¥C ¹⁾	1460/980	84.0/71.0	0.86/0.73	12/5.6	7.1/4.5	39.2/19.5	1.8/1.3	2.5/2.0	0.048	59
10.5/3.5	M3AP 160 M	3GAA 168 354-¥¥C ¹⁾	1460/965	87.0/75.5	0.84/0.78	21/8.6	6.4/4.1	69/35	2.0/1.3	2.5/1.7	0.089	101
14.5/4.5	M3AP 160 L	3GAA 168 355-¥¥C ¹⁾	1460/970	88.5/77.0	0.85/0.76	28/11	6.9/4.6	95/44	2.2/1.5	2.6/1.9	0.119	125
16/5	M3AP 180 M	3GAA 188 359-¥¥C ¹⁾	1470/980	89.0/78.0	0.83/0.73	31/12.5	6.3/4.6	104/49	1.9/1.5	2.5/2.0	0.176	140
20/6.5	M3AP 180 L	3GAA 188 360-¥¥C ¹⁾	1470/980	90.0/79.5	0.83/0.74	39/16	7.2/5.0	130/63	2.4/1.8	2.7/2.0	0.224	168
23/7.2	M3AP 200 MLA	3GAA 208 213-¥¥C ¹⁾	1475/985	89.5/84.0	0.88/0.87	43/15	7.7/7.8	149/70	1.6/1.9	2.8/2.9	0.44	192
30/9	M3AP 200 MLB	3GAA 208 214-¥¥C ¹⁾	1470/990	90.0/86.6	0.90/0.84	54/18.2	7.7/9.5	195/87	1.6/1.7	2.7/2.9	0.53	217
34/11	M3AP 225 SMB	3GAA 228 209-¥¥C ¹⁾	1470/985	91.0/85.0	0.91/0.89	60/21	7.7/6.7	221/107	1.5/1.3	2.7/2.3	0.67	247
42/14	M3AP 225 SMC	3GAA 228 210-¥¥C ¹⁾	1475/985	91.5/89.0	0.89/0.89	75/27	8.4/6.8	272/136	1.7/1.4	3.0/2.3	0.78	277
63/18.5	M3AP 250 SMB	3GAA 258 205-¥¥C ¹⁾	1475/985	93.5/87.0	0.89/0.79	110/40	7.5/7.3	408/179	2.4/3.0	2.7/2.6	0.89	361
1500/750 r/min = 4/8 poles			400 V 50 Hz			Fan drive, two separate windings						
3/0.4	M3AP 112 M	3GAA 118 206-¥¥C ¹⁾	1440/730	81.0/51.0	0.87/0.58	6.2/2	6.8/3.8	19.9/5.2	1.5/1.6	2.4/2.6	0.018	32
4/0.6	M3AP 132 S	3GAA 138 231-¥¥C ¹⁾	1465/740	84.0/51.0	0.84/0.53	8.2/3.2	6.5/3.5	26.1/7.7	1.5/1.1	2.4/2.5	0.038	48
5.5/0.9	M3AP 132 M	3GAA 138 232-¥¥C ¹⁾	1455/735	84.0/53.0	0.87/0.64	10.9/3.9	6.2/3.1	36.1/11.7	1.5/1.1	2.2/2.0	0.048	59
9/1.3	M3AP 160 M	3GAA 168 356-¥¥C ¹⁾	1460/735	87.0/60.0	0.84/0.53	18/5.9	6.6/4.0	59/17	2.0/2.2	2.5/2.7	0.089	100
13/1.8	M3AP 160 L	3GAA 168 357-¥¥C ¹⁾	1455/735	88.0/64.0	0.85/0.53	26/8.2	6.0/4.1	89/26	1.9/2.2	2.3/2.6	0.119	125
16/2.3	M3AP 180 M	3GAA 188 361-¥¥C ¹⁾	1475/740	88.5/64.0	0.82/0.53	32/9.7	6.8/4.1	104/30	2.2/2.2	2.7/2.6	0.176	139
19/2.7	M3AP 180 L	3GAA 188 362-¥¥C ¹⁾	1475/740	89.5/68.0	0.83/0.54	37/10.5	7.5/7.2	123/35	2.6/2.6	2.9/2.6	0.224	168
26/3.3	M3AP 200 MLA	3GAA 208 216-¥¥C ¹⁾	1475/740	91.0/73.0	0.85/0.59	49/11	6.9/4.6	168/46	2.1/2.2	2.5/2.3	0.28	197
30/3.8	M3AP 200 MLB	3GAA 208 217-¥¥C ¹⁾	1470/740	91.5/75.5	0.86/0.59	55/12.5	6.7/4.6	195/49	2.1/2.2	2.4/2.2	0.34	222
38/5.2	M3AP 225 SMB	3GAA 228 211-¥¥C ¹⁾	1480/740	91.5/80.5	0.84/0.63	72/15	7.3/5.2	245/67	2.1/2.3	2.6/2.3	0.41	252
46/7	M3AP 225 SMC	3GAA 228 212-¥¥C ¹⁾	1480/740	92.5/82.0	0.86/0.66	85/19	7.7/4.9	297/90	2.3/2.1	2.7/2.1	0.49	287
63/10	M3AP 250 SMB	3GAA 258 206-¥¥C ¹⁾	1475/740	93.5/83.0	0.89/0.65	110/27	7.5/6.0	408/129	2.4/3.0	2.7/2.7	0.89	361

Data for motor size 280 on request.

¹⁾ When ordering, the following variant code has to be added to the product code:

199 = Extreme heavy duty design. Type designation M3AP

The bullets in the product code indicate choice of mounting arrangement, voltage and frequency generation code (see ordering information page).

LV Process performance aluminum motors

Technical data for totally enclosed squirrel cage three phase motors, two-speed

IP 55 – IC 411 – Insulation class F, temperature rise class F

Output kW	Motor type	Product code	Speed n r/min	Eff- ciency %	Power factor cos φ	Current		Torque			Moment of inertia J = Å GD ² kgm ²	Weight kg
						I _N A	I _s I _N	T Nm	T _s T _N	T _{max} T _N		
1500/750 r/min = 4-8 poles			400 V 50 Hz			Fan drive, Dahlander-connection						
3.5/0.7	M3AP 112 M	3GAA 118 126-¥¥C ¹⁾	1430/720	81.0/71.0	0.89/0.58	7/2.5	6.8/4.4	23.4/9.3	1.6/1.7	2.5/2.7	0.018	32
5/1	M3AP 132 S	3GAA 138 131-¥¥C ¹⁾	1450/725	83.0/74.0	0.87/0.59	9.9/3.3	6.4/3.6	32.9/13.2	1.5/1.0	2.3/2.0	0.038	48
6.8/1.4	M3AP 132 M	3GAA 138 132-¥¥C ¹⁾	1460/730	85.0/73.0	0.84/0.55	13.7/5.1	7.6/3.6	44.5/18.3	2.0/1.4	2.8/2.7	0.048	59
10.5/2.2	M3AP 160 M	3GAA 168 304-¥¥C ¹⁾	1460/735	87.5/79.0	0.84/0.54	21/7.4	6.9/3.7	69/29	2.2/1.5	2.7/2.3	0.089	102
15.5/2.7	M3AP 160 L	3GAA 168 305-¥¥C ¹⁾	1460/735	88.5/79.5	0.85/0.51	30/9.5	6.9/3.9	101/35	2.2/1.7	2.6/2.6	0.119	125
17/3.4	M3AP 180 M	3GAA 188 307-¥¥C ¹⁾	1470/730	88.5/78.0	0.85/0.56	33/11	5.8/4.3	111/44	1.7/1.2	2.3/1.9	0.176	146
22/4.4	M3AP 180 L	3GAA 188 308-¥¥C ¹⁾	1475/735	89.5/79.0	0.83/0.53	43/15	6.7/3.9	143/57	2.0/1.7	2.6/2.3	0.224	170
29/6.5	M3AP 200 MLA	3GAA 208 116-¥¥C ¹⁾	1470/730	90.5/86.0	0.86/0.64	54/17	6.9/4.2	188/81	2.2/1.9	2.4/1.9	0.28	197
33/8	M3AP 200 MLB	3GAA 208 117-¥¥C ¹⁾	1475/730	91.5/86.5	0.86/0.64	61/21	7.8/4.2	214/105	2.6/1.9	2.6/1.8	0.34	222
42/10	M3AP 225 SMB	3GAA 228 111-¥¥C ¹⁾	1480/740	92.0/89.5	0.86/0.64	85/27	7.8/5.0	271/129	2.5/2.2	3.0/2.3	0.49	287
50/11	M3AP 225 SMC	3GAA 228 112-¥¥C ¹⁾	1465/735	92.5/89.5	0.87/0.65	91/28	7.3/4.7	324/143	2.3/2.0	2.5/2.0	0.49	287
60/15	M3AP 250 SMB	3GAA 258 106-¥¥C ¹⁾	1475/735	93.0/90.0	0.86/0.70	104/34	7.9/4.7	388/195	2.6/2.1	2.7/2.0	0.89	361
1000/750 r/min = 6/8 poles			400 V 50 Hz			Fan drive, two separate windings						
17/7.5	M3AP 200 MLB	3GAA 208 221-¥¥C ¹⁾	985/740	88.0/81.5	0.85/0.77	33/17	7.1/6.4	165/97	2.2/2.2	2.5/2.5	0.42	202
20/9	M3AP 200 MLC	3GAA 208 222-¥¥C ¹⁾	985/740	88.5/82.5	0.84/0.74	39/21	7.6/7.0	194/116	2.4/2.6	2.7/2.9	0.48	217
26/12	M3AP 225 SMB	3GAA 228 215-¥¥C ¹⁾	985/740	89.5/84.5	0.85/0.76	49/27	7.4/7.1	252/155	2.2/2.4	2.5/2.7	0.63	247
32/14	M3AP 225 SMC	3GAA 228 216-¥¥C ¹⁾	985/740	90.5/85.5	0.83/0.76	62/31	7.0/7.2	310/180	2.4/2.5	2.4/2.5	0.74	272
43/15	M3AP 250 SMC	3GAA 258 208-¥¥C ¹⁾	990/745	91.0/86.0	0.84/0.75	81/34	7.3/7.4	415/198	2.2/2.7	2.5/2.8	1.41	346
3000/1500 r/min = 2/4 poles			400 V 50 Hz			Constant torque, two separate windings						
2.6/1.3	M3AP 112 M	3GAA 118 201-¥¥C ¹⁾	2900/1460	80.0/75.0	0.92/0.72	5.1/3.5	6.4/5.0	8.6/8.5	1.6/1.6	2.3/2.3	0.012	32
4.4/2.2	M3AP 132 SB	3GAA 138 201-¥¥C ¹⁾	2925/1450	81.0/74.0	0.86/0.73	9.1/5.9	7.3/4.4	14.4/14.5	2.0/1.3	2.3/2.2	0.016	42
5.6/2.8	M3AP 132 M	3GAA 138 202-¥¥C ¹⁾	2885/1440	82.0/77.0	0.93/0.75	10.6/7	6.7/5.0	18.5/18.6	1.8/1.4	2.1/2.2	0.022	56
12/6	M3AP 160 M	3GAA 168 359-¥¥C ¹⁾	2835/1460	87.5/84.5	0.92/0.80	22/13	7.7/6.0	39/39	2.1/2.3	2.8/2.4	0.054	100
15/7.5	M3AP 160 L	3GAA 168 360-¥¥C ¹⁾	2940/1460	88.5/84.5	0.93/0.78	27/16.5	7.9/6.0	49/49	2.2/2.4	2.9/2.4	0.057	107
18/9	M3AP 180 L	3GAA 188 352-¥¥C ¹⁾	2945/1460	89.0/84.0	0.90/0.77	32/20	7.7/5.2	58/59	2.5/2.3	2.8/2.1	0.108	161
23/12	M3AP 200 MLA	3GAA 208 201-¥¥C ¹⁾	2960/1475	90.0/89.0	0.89/0.85	42/23	7.8/7.4	74/77	1.7/2.2	2.8/2.5	0.28	195
30/16	M3AP 200 MLB	3GAA 208 202-¥¥C ¹⁾	2960/1475	91.0/90.0	0.90/0.87	53/30	8.2/7.3	97/104	1.8/2.2	2.9/2.5	0.34	221
36/18	M3AP 225 SMB	3GAA 228 201-¥¥C ¹⁾	2960/1480	91.5/91.5	0.91/0.76	63/38	8.0/7.2	116/116	2.5/3.8	2.7/2.5	0.26	258
40/20	M3AP 225 SMC	3GAA 228 202-¥¥C ¹⁾	2960/1475	92.0/91.5	0.91/0.79	69/41	8.5/6.5	129/129	2.8/3.3	2.8/2.2	0.29	283
50/25	M3AP 250 SMB	3GAA 258 201-¥¥C ¹⁾	2965/1485	93.0/93.0	0.91/0.76	86/52	8.9/8.5	161/161	2.1/3.5	2.9/2.9	0.57	333
3000/1500 r/min = 2-4 poles			400 V 50 Hz			Constant torque, Dahlander-connection						
4/2.6	M3AP 112 M	3GAA 118 101-¥¥C ¹⁾	2865/1430	82.0/77.0	0.94/0.76	7.6/6.5	6.3/6.2	13.3/17.4	1.8/2.3	2.1/2.6	0.012	32
4.7/3.1	M3AP 132 SB	3GAA 138 101-¥¥C ¹⁾	2820/1420	79.0/77.0	0.93/0.76	9.2/7.7	5.5/5.7	15.9/20.8	1.8/2.2	2.1/2.4	0.016	42
7.2/4.8	M3AP 132 M	3GAA 138 102-¥¥C ¹⁾	2870/1435	84.0/81.0	0.93/0.76	13.3/11.5	7.1/6.2	24/31.9	2.4/2.5	2.6/2.7	0.022	56
9/6.5	M3AP 160 MA	3GAA 168 306-¥¥C ¹⁾	2885/1440	83.0/82.0	0.92/0.74	17.1/15.6	4.6/4.3	40/43	1.3/1.7	1.9/1.9	0.039	81
12.5/9	M3AP 160 M	3GAA 168 307-¥¥C ¹⁾	2890/1440	85.5/85.5	0.93/0.80	22.5/19	5.2/4.6	41/60	1.4/1.8	1.9/1.9	0.054	100
15/10.5	M3AP 160 L	3GAA 168 308-¥¥C ¹⁾	2900/1445	87.0/86.0	0.93/0.77	27/23	5.8/4.9	49/69	1.6/2.1	2.1/2.1	0.057	107
18/12	M3AP 180 M	3GAA 188 301-¥¥C ¹⁾	2940/1455	89.0/89.0	0.88/0.79	33/25	6.8/5.3	59/79	2.1/2.4	2.6/2.2	0.094	141
24/17	M3AP 180 L	3GAA 188 302-¥¥C ¹⁾	2945/1455	90.0/90.0	0.89/0.80	43/34	7.4/5.2	78/111	2.4/2.4	2.8/2.1	0.108	161
32/24	M3AP 200 MLA	3GAA 208 101-¥¥C ¹⁾	2940/1470	89.0/90.5	0.89/0.86	58/45	6.8/5.9	104/156	1.8/2.1	2.4/2.1	0.28	197
39/29	M3AP 200 MLB	3GAA 208 102-¥¥C ¹⁾	2950/1470	90.5/91.0	0.84/0.86	75/53	6.8/7.0	126/188	1.7/2.2	2.6/2.4	0.34	222
42/32	M3AP 225 SMB	3GAA 228 101-¥¥C ¹⁾	2955/1475	92.5/93.0	0.92/0.88	71/57	7.1/6.5	136/207	1.5/1.9	2.5/2.3	0.49	252
50/40	M3AP 225 SMC	3GAA 228 102-¥¥C ¹⁾	2960/1475	92.5/93.0	0.84/0.87	94/71	7.4/7.1	161/259	1.8/2.0	2.8/2.5	0.49	287
68/50	M3AP 250 SMB	3GAA 258 101-¥¥C ¹⁾	2940/1475	93.0/93.5	0.93/0.88	113/87	6.6/6.9	220/324	1.5/2.1	2.4/2.5	0.89	335

Data for motor size 280 on request.

¹⁾ When ordering, the following variant code has to be added to the product code:

199 = Extreme heavy duty design. Type designation M3AP

The bullets in the product code indicate choice of mounting arrangement, voltage and frequency generation code (see ordering information page).

LV Process performance aluminum motors

Technical data for totally enclosed squirrel cage three phase motors, two-speed

IP 55 – IC 411 – Insulation class F, temperature rise class F

Output kW	Motor type	Product code	Speed n r/min	Eficiency %	Power factor cos φ	Current		Torque			Moment of inertia J = Å GD ² kgm ²	Weight kg
						I _N A	I _s / I _N	T Nm	T _s / T _N	T _{max} / T _N		
1500/1000 r/min =4-6 poles			400 V 50 Hz			Constant torque, two separate windings						
2.6/1.7	M3AP 112 M	3GAA 118 202-¥¥C ¹⁾	1445/960	80.0/73.0	0.86/0.76	5.5/4.4	5.9/5.2	17.2/16.9	1.5/1.5	2.2/2.4	0.018	33
3.3/2.2	M3AP 132 S	3GAA 138 223-¥¥C ¹⁾	1470/980	82.0/76.0	0.82/0.65	7.1/6.4	6.8/4.6	21.4/21.4	1.4/1.2	2.5/2.4	0.038	48
4.5/3	M3AP 132 M	3GAA 138 224-¥¥C ¹⁾	1470/980	82.0/77.0	0.85/0.70	9.3/8	7.2/5.6	29.2/29.2	1.4/1.5	2.3/2.6	0.048	59
7.5/5.5	M3AP 160 M	3GAA 168 361-¥¥C ¹⁾	1465/965	85.5/80.5	0.83/0.77	15.5/13	7.1/4.7	49/54	2.1/1.8	2.7/1.9	0.089	101
11.5/8.5	M3AP 160 L	3GAA 168 362-¥¥C ¹⁾	1465/965	86.5/82.5	0.84/0.76	23/19.5	7.0/4.9	75/84	2.1/1.8	2.8/2.0	0.119	125
13/8	M3AP 180 M	3GAA 188 353-¥¥C ¹⁾	1475/975	88.0/82.5	0.82/0.75	26/19	6.5/4.3	84/78	1.9/1.4	2.6/1.8	0.176	140
15/10	M3AP 180 L	3GAA 188 354-¥¥C ¹⁾	1475/975	88.5/84.0	0.83/0.74	30/23	7.1/4.4	97/98	2.3/1.5	2.7/1.9	0.224	168
18/12	M3AP 200 MLA	3GAA 208 204-¥¥C ¹⁾	1475/985	88.5/86.0	0.91/0.86	33/24	7.6/7.8	117/116	2.1/2.6	2.5/2.6	0.42	202
22/14.7	M3AP 200 MLB	3GAA 208 205-¥¥C ¹⁾	1480/985	89.5/86.5	0.89/0.87	40/29	8.2/7.6	142/143	2.4/2.6	2.8/2.5	0.48	217
32/21	M3AP 225 SMB	3GAA 228 203-¥¥C ¹⁾	1480/985	90.0/89.5	0.88/0.86	58/40	8.6/8.0	206/204	2.3/2.4	2.8/2.7	0.63	247
36/24	M3AP 225 SMC	3GAA 228 204-¥¥C ¹⁾	1480/985	90.5/90.0	0.88/0.87	66/45	8.4/7.4	232/233	2.2/2.2	2.8/2.5	0.74	272
50/32	M3AP 250 SMB	3GAA 258 202-¥¥C ¹⁾	1475/985	92.5/90.5	0.89/0.80	89/65	7.5/7.1	324/310	2.3/3.1	2.6/2.6	0.89	361
1500/750 r/min = 4/8 poles			400 V 50 Hz			Constant torque, two separate windings						
1.8/0.9	M3AP 112 M	3GAA 118 203-¥¥C ¹⁾	1470/715	77.0/65.0	0.76/0.66	4.4/3	6.5/4.0	11.7/12	1.2/1.6	2.2/2.4	0.018	32
2.5/1.3	M3AP 132 S	3GAA 138 225-¥¥C ¹⁾	1470/730	80.0/69.0	0.79/0.58	5.7/4.7	6.7/4.4	16.2/17	1.6/1.4	2.6/2.7	0.038	48
3.3/1.7	M3AP 132 M	3GAA 138 226-¥¥C ¹⁾	1470/725	81.0/71.0	0.83/0.67	7.1/5.2	8.0/4.8	21.4/22.4	1.8/1.8	2.7/2.2	0.048	59
5.5/2.7	M3AP 160 M	3GAA 168 363-¥¥C ¹⁾	1465/730	85.0/71.0	0.83/0.57	11.5/9.6	5.6/4.0	36/35	1.7/2.0	2.2/2.3	0.089	100
9/4.5	M3AP 160 L	3GAA 168 364-¥¥C ¹⁾	1465/730	86.5/73.5	0.83/0.56	18/16	7.0/4.1	59/59	2.1/2.1	2.7/2.5	0.119	125
14/7	M3AP 180 L	3GAA 188 356-¥¥C ¹⁾	1475/735	88.0/76.0	0.83/0.56	28/24	7.7/4.2	91/91	2.6/2.3	2.9/2.3	0.225	168
18.5/9.4	M3AP 200 MLA	3GAA 208 207-¥¥C ¹⁾	1475/730	89.5/82.5	0.85/0.65	35/26	7.3/4.3	120/123	2.2/1.9	2.5/1.8	0.28	197
22/11	M3AP 200 MLB	3GAA 208 208-¥¥C ¹⁾	1480/735	90.5/83.0	0.84/0.60	42/32	8.4/4.7	142/143	2.6/2.4	2.9/2.2	0.34	222
28/14	M3AP 225 SMB	3GAA 228 205-¥¥C ¹⁾	1480/735	90.0/85.5	0.85/0.61	53/39	7.7/4.9	181/182	2.1/2.4	2.7/2.2	0.41	252
34/17	M3AP 225 SMC	3GAA 228 206-¥¥C ¹⁾	1480/735	92.0/87.0	0.86/0.66	63/43	7.9/4.8	219/221	2.2/2.2	2.7/2.0	0.49	287
50/25	M3AP 250 SMB	3GAA 258 203-¥¥C ¹⁾	1480/740	92.5/88.0	0.87/0.60	90/68	8.6/6.0	323/323	2.6/3.5	3.0/2.9	0.89	361
1500/750 r/min = 4-8 poles			400 V 50 Hz			Constant torque, Dahlander-connection						
2.5/1.5	M3AP 112 M	3GAA 118 103-¥¥C ¹⁾	1410/705	78.0/67.0	0.90/0.66	5.1/4.9	5.5/4.1	16.9/20.3	1.4/1.5	2.1/2.4	0.018	32
3.8/1.9	M3AP 132 S	3GAA 138 125-¥¥C ¹⁾	1450/730	82.0/70.0	0.86/0.52	7.7/7.6	5.6/3.7	25/24.9	1.4/1.3	2.1/2.7	0.038	48
5/2.5	M3AP 132 M	3GAA 138 126-¥¥C ¹⁾	1455/730	85.0/73.0	0.88/0.52	9.6/9.6	6.9/4.8	32.8/32.7	1.7/2.0	2.4/2.8	0.048	59
8/4.5	M3AP 160 M	3GAA 168 309-¥¥C ¹⁾	1440/730	84.5/79.5	0.86/0.60	16/13.5	4.5/3.4	53/59	1.3/1.4	1.8/1.9	0.089	100
12/7	M3AP 160 L	3GAA 168 310-¥¥C ¹⁾	1445/730	86.5/81.0	0.87/0.59	23/21	5.0/3.5	79/92	1.5/1.4	1.9/1.9	0.119	125
16/8	M3AP 180 L	3GAA 188 304-¥¥C ¹⁾	1460/730	88.0/78.5	0.86/0.53	31/28	1.9/3.4	105/104	1.4/1.6	1.9/2.1	0.224	168
22/13	M3AP 200 MLA	3GAA 208 107-¥¥C ¹⁾	1475/735	87.5/86.0	0.81/0.69	45/32	6.5/5.9	142/169	2.0/2.5	2.6/2.7	0.36	182
25/15	M3AP 200 MLB	3GAA 208 108-¥¥C ¹⁾	1475/735	89.0/86.0	0.86/0.67	47/38	7.6/6.0	162/195	2.2/2.6	2.7/2.7	0.42	202
29/17	M3AP 200 MLC	3GAA 208 109-¥¥C ¹⁾	1475/735	90.0/88.0	0.91/0.75	52/38	7.2/6.1	188/221	2.2/2.6	2.4/2.4	0.48	217
35/21	M3AP 225 SMB	3GAA 228 105-¥¥C ¹⁾	1475/735	90.0/89.0	0.90/0.74	63/47	6.7/5.8	227/273	1.7/2.1	2.2/2.3	0.63	247
42/25	M3AP 225 SMC	3GAA 228 106-¥¥C ¹⁾	1475/735	91.0/89.5	0.91/0.75	74/54	6.8/5.9	272/325	1.8/2.1	2.2/2.2	0.74	272
55/33	M3AP 250 SMB	3GAA 258 103-¥¥C ¹⁾	1480/740	92.0/90.5	0.90/0.75	97/71	7.3/6.4	355/426	2.1/2.5	2.5/2.5	1.5	346
1000/750 r/min = 6/8 poles			400 V 50 Hz			Constant torque, two separate windings						
1.6/0.8	M3AP 112 M	3GAA 118 207-¥¥C ¹⁾	965/725	72.9/60.0	0.70/0.64	4.5/3	5.6/4.4	15.8/10.6	2.3/2.3	2.6/2.4	0.015	35
2.3/1.3	M3AP 132 S	3GAA 138 213-¥¥C ¹⁾	975/730	77.2/63.5	0.72/0.64	6.8/4.6	6.4/4.2	25.4/17	1.6/1.5	2.8/2.3	0.04	48
3.5/1.6	M3AP 132 M	3GAA 138 214-¥¥C ¹⁾	975/730	78.8/65.8	0.72/0.66	9/5.2	7.1/5.1	34.2/20.9	2.0/1.9	2.9/2.4	0.041	48
16/12	M3AP 200 MLB	3GAA 208 219-¥¥C ¹⁾	985/740	86.5/82.5	0.85/0.73	31/29	7.0/6.3	155/155	2.1/2.4	2.4/2.6	0.42	242
18/13.5	M3AP 200 MLC	3GAA 208 220-¥¥C ¹⁾	985/740	87.5/83.5	0.83/0.72	36/32	7.9/6.6	174/174	2.5/2.6	2.8/2.8	0.48	217
23/17	M3AP 225 SMB	3GAA 228 213-¥¥C ¹⁾	985/740	89.0/85.5	0.84/0.78	46/37	7.9/6.3	222/220	2.3/2.2	2.7/2.3	0.63	247
28/20	M3AP 225 SMC	3GAA 228 214-¥¥C ¹⁾	985/740	89.0/86.5	0.86/0.77	57/43	7.1/6.5	272/259	2.0/2.3	2.4/2.4	0.74	272
37/27	M3AP 250 SMB	3GAA 258 207-¥¥C ¹⁾	990/740	90.0/87.5	0.83/0.75	71/59	7.8/6.7	357/348	2.3/2.5	2.7/2.5	1.41	346

Data for motor size 280 on request.

¹⁾ When ordering, the following variant code has to be added to the product code:
199 = Extreme heavy duty design. Type designation M3AP

The bullets in the product code indicate choice of mounting arrangement, voltage and frequency generation code (see ordering information page).

LV Process performance aluminum motors - Variant codes

Code ¹⁾	Variant	Motor size			
		112-132	160-180	200-250	280
Balancing					
052	Vibration acc. to grade A (IEC 60034-14).	S	S	S	S
417	Vibration acc. to grade B (IEC 60034-14).	R	R	R	R
423	Balancing without key.	P	P	P	P
424	Full key balancing.	P	P	P	P
Bearings and lubrication					
036	Transport lock for bearings.	M	M	M	M
037	Roller bearing at D-end.	NA	M	M	M
039	Cold resistant grease (-55... +100j C).	M	M	M	M
040	Heat resistant grease (-25... +150j C).	S	S	S	S
041	Bearings regreasable via grease nipples.	M	S	S	S
042	Locked drive-end. Standard for sizes 112-132, Banged versions.	S	S	S	S
043	SPM nipples.	M	S	S	S
057	2RS bearings at both ends.	M	M	M	M
058	Angular contact bearing at D-end, shaft force away from bearing.	M	M	M	M
059	Angular contact bearing at N-end, shaft force towards bearing.	M	M	M	M
107	Pt100 2-wire in bearings.	NA	P	P	P
188	63-series bearings.	S	S	S	S
796	Grease nipples JIS B 1575 PT 1/8 Type A. Stainless steel.	M	M	M	M
797	Stainless steel SPM nipples.	M	M	M	M
798	Stainless steel grease nipples.	M	M	M	M
Branch standard designs					
071	Cooling tower duty.	P	P	P	P
079	Silumin-alloy rotor cage.	R	R	R	R
142	Manilla connection.	P	P	P	P
178	Stainless steel/acid proof bolts.	S	S	S	S
199	Extreme heavy duty design. Type designation M3AP.	S	S	S	S
209	Non-standard voltage or frequency (special winding).	P	P	P	P
217	Cast iron D-end shield (on foot-mounted aluminum motor).	S	S	S	S
425	Corrosion protected stator and rotor core.	P	P	P	P
785	Reinforced tropicalization.	R	R	R	R
Cooling system					
053	Metal fan cover.	S	S	S	S
068	Metal fan.	M	M	M	M
075	Cooling method IC418 (without fan).	R	R	R	R
183	Separate motor cooling (fan axial, N-end).	NA	M	M	M
189	Separate motor cooling, IP44, 400 V 50 Hz (fan axial, N-end)	M	M	M	M
793	Fan for reduced noise level (2 pole fan).	R	R	R	R
794	Fan for reduced noise level (4 pole fan).	R	R	R	R

¹⁾ Certain variant codes cannot be used simultaneously.

S = Included as standard
M = On modification of a stocked motor, or on new manufacture, the number per order may be limited.

P = New manufacture only
R = On request
NA = Not applicable

Code 1)	Variant	Motor size			
		112-132	160-180	200-250	280
Dimension drawing					
141	Binding dimension drawing	M	M	M	M
Drain holes					
065	Plugged drain holes.	M	M	M	M
Earthing bolt					
067	External earthing bolt.	M	M	M	M
Hazardous environments					
See catalogue 0Motors for Hazardous Environments, Ex catalogue GB0 for details.					
407	Ex N design, fulfilling BS5000/16, certificate provided.	R	R	R	R
480	Ex nA, fulfilling EN 50021.	M	M	M	M
452	DIP according to EN 50281-1-1, T = 125°C, category 3D, IP 55 (for zone 22)	M	M	M	M
453	DIP according to EN 50281-1-1, T = 125°C, category 2D, IP 65 (for zone 21)	M	M	M	M
Heating elements					
	Motor size	Element capacity			
	112-160	25 W			
	180-280	50 W			
450	Heating element, 100-120 V.	M	M	M	M
451	Heating element, 200-240 V.	M	M	M	M
Insulation systems					
014	Winding insulation class H.	P	P	P	P
405	Special winding insulation for frequency converter supply.	P	P	P	P
406	Winding for supply > 690 ≤ 1000 V.	R	R	P	P
Marine Motors					
See catalogue 0Marine Motors0 for details.					
Mounting arrangements					
007	IM 3001 flange mounted, IEC flange, from IM 1001 (B5 from B3).	NA	NA	M	M
008	IM 2101 foot/flange mounted, IEC flange, from IM 1001 (B34 from B3).	M	NA	NA	NA
009	IM 2001 foot/flange mounted, IEC flange, from IM 1001 (B35 from B3).	M	M	M	M
047	IM 3601 flange mounted, IEC flange, from IM 3001 (B14 from B5).	M	M	NA	NA
048	IM 3001 flange mounted, IEC flange, from IM 3601 (B5 from B14), flange mounted motor with small flange. Large flange with clearance holes.	M	NA	NA	NA
066	Modified for non-standard mounting position (please specify IM xxxx). (must be ordered for all mounting arrangements excluding IM B3 (1001) and B5 (3001).	M	M	M	M
Painting					
114	Special paint colour, standard grade. RAL-colour no. must be specified.	M	M	M	M
179	Special paint specification.	R	R	R	R

1) Certain variant codes cannot be used simultaneously.

S = Included as standard
M = On modification of a stocked motor, or on new manufacture, the number per order may be limited.

P = New manufacture only
R = On request
NA = Not applicable

Code ¹⁾	Variant	Motor size			
		112-132	160-180	200-250	280
Protection					
005	Metal protective roof, vertical motor, shaft down.	M	M	M	M
158	Degree of protection IP65. Dust proof version.	M	M	M	M
211	Weather protected, IP xx W	M	M	M	M
403	Degree of protection IP56.	M	M	M	M
784	Gamma-seal at D-end.	R	R	R	R
Rating and instruction plates					
002	Restamping voltage, frequency, and output, continuous duty.	M	M	M	M
003	Individual serial number.	M	M	M	M
004	Additional text on standard rating plate.	R	M	M	M
095	Restamping of output (maintained voltage, frequency), intermittent duty.	M	M	M	M
098	Stainless rating plate.	S	S	S	S
135	Mounting of additional identification plate, stainless.	R	R	R	R
138	Mounting of additional identification plate, aluminum.	M	M	M	M
139	Additional identification plate delivered loose.	M	M	M	M
160	Additional rating plate affixed.	M	M	M	M
161	Additional rating plate delivered loose.	M	M	M	M
162	Rating plate fixed to stator.	M	S	S	S
163	Frequency converter rating plate. Rating data according to quotation.	NA	M	M	M
Shaft and rotor					
069	Two shaft extensions as per basic catalogue.	P	P	P	P
070	One or two special shaft extensions, standard shaft material.	R	R	R	R
131	Motor delivered with half key (key not exceeding shaft material).	M	M	M	M
165	Shaft extension with open keyway.	P	P	P	P
410	Stainless steel shaft, standard or non-standard design. One or two shaft extensions.	R	R	R	R
Standards and regulations					
010	Fulfilling CSA Safety Certificate.	M	M	M	M
011	Fulfilling CSA Energy Efficiency Verification (010 included).	M	M	M	M
408	Fulfilling EPA certification requirements, CC031A.	P	P	P	P
778	GOST Export/Import Certificate (Russia).	M	M	M	M
779	SASO Export/Import Certificate (Saudi Arabia).	M	M	M	M
Stator winding temperature sensors					
121	Bimetal detectors, break type (NCC), (3 in series), 130°C, in stator winding.	M	M	M	M
122	Bimetal detectors, break type (NCC), (3 in series), 150°C, in stator winding.	M	M	M	M
123	Bimetal detectors, break type (NCC), (3 in series), 170°C, in stator winding.	M	M	M	M
125	Bimetal detectors, break type (NCC), (2 x 3 in series), 150°C, in stator winding.	M	M	M	M

¹⁾ Certain variant codes cannot be used simultaneously.

S = Included as standard
M = On modification of a stocked motor, or on new manufacture, the number per order may be limited.

P = New manufacture only
R = On request
NA = Not applicable

Code 1)	Variant	Motor size			
		112-132	160-180	200-250	280
127	Bimetal detectors, break type (NCC), (3 in series, 130 _i C & 3 in series, 150 _i C), in stator winding.	M	M	M	M
321	Bimetal detectors, closing type (NO), (3 in parallel), 130 _i C, in stator winding.	R	R	R	R
322	Bimetal detectors, closing type (NO), (3 in parallel), 150 _i C, in stator winding.	R	R	R	R
323	Bimetal detectors, closing type (NO), (3 in parallel), 170 _i C, in stator winding.	R	R	R	R
325	Bimetal detectors, closing type (NO), (2x3 in parallel), 150 _i C, in stator winding.	R	R	R	R
327	Bimetal detectors, closing type (NO), (3 in parallel, 130 _i C & 3 in parallel, 150 _i C) in stator winding.	R	R	R	R
435	PTC - thermistors (3 in series), 130 _i C, 3 in stator winding.	M	M	M	M
436	PTC thermistors (3 in series), 150 _i C, in stator winding.	M	S	S	S
437	PTC - thermistors (3 in series), 170 _i C, in stator winding.	M	M	M	M
439	PTC - thermistors (2x3 in series), 150 _i C, in stator winding.	M	M	M	M
440	PTC - thermistors (3 in series, 110 _i C, 3 in series, 130 _i C), in stator winding.	R	R	R	R
441	PTC - thermistors (3 in series, 130 _i C & 3 in series, 150 _i C), in stator winding.	M	M	M	M
442	PTC - thermistors, (3 in series, 150 _i C & 3 in series, 170 _i C), in stator winding.	M	M	M	M
445	Pt100 2-wire in stator winding, 1 per phase.	M	M	M	M
446	Pt100 2-wire in stator winding, 2 per phase.	NA	M	M	M
Terminal box					
015	Motor supplied in D-connection.	M	M	M	M
017	Motor supplied in Y-connection.	M	M	M	M
019	Larger than standard terminal box.	M	M	S	S
021	Terminal box LHS, seen from D-end (= L prod.code).	NA	NA	P	P
180	Terminal box RHS, seen from (reconnection from D).	NA	NA	P	P
112	Mounting of plug-in contact.	R	NA	NA	NA
136	Extended cable connection, standard terminal box. 2 m long connection cable.	R	R	R	R
187	Cable glands of non-standard design.	R	R	R	R
230	Standard metal cable glands.	M	M	M	M
731	Two standard metal cable glands.	M	M	M	M
402	Terminal box adapted for Al cables.	NA	NA	P	P
418	Separate terminal box for auxiliaries, standard material.	M	M	M	M
467	Lower than standard terminal box and rubber extended cable. Cable, length 2 m, included.	P	P	P	P

1) Certain variant codes cannot be used simultaneously.

S = Included as standard
M = On modification of a stocked motor,
or on new manufacture,
the number per order may be limited.

P = New manufacture
only
R = On request
NA = Not applicable

Code 1)	Variant	Motor size			
		112-132	160-180	200-250	280
Testing					
140	Test confirmation.	M	M	M	M
145	Type test report from a catalogue motor, 400 V 50 Hz.	M	M	M	M
146	Type test with report for motor from specific delivery batch.	M	M	M	M
147	Type test report with motor from spec. del. batch, customer witnessed.	M	M	M	M
148	Routine test report, Witnessed routine test = 146.	M	M	M	M
149	Test according to separate test specification.	R	R	R	R
153	Reduced test for classification society.	M	M	M	M
221	Type test and multi-point load test with report for motor from spec. del. batch.	M	M	M	M
222	Torque/speed curve, type test and multi-point load test with report from spec. del. batch.	M	M	M	M
760	Vibration level test.	M	M	M	M
762	Noise level test.	M	M	M	M
764	Complete test with ABB frequency converter.	R	R	R	R
Variable speed drives					
For long cables, see code 405 (Insulation systems).					
701	Insulated bearing at N-end. For fan and pump duty up to 500V.	NA	NA	M	M
704	EMC cable gland.	M	M	M	M
Separate motor cooling					
183	Separate motor cooling (fan axial, N-end).	NA	M	M	M
189	Separate motor cooling, IP 44, 400 V 50 Hz (fan axial, N-end).	M	M	M	M
Mounting of tacho; tacho not included					
182	Pulse sensor mounted as specified.	R	R	R	R
470	Prepared for hollow shaft pulse tacho (Leine & Linde equivalent).	P	M	M	M
570	Prepared for hollow shaft pulse tacho (L&L 503).	R	M	M	M

1) Certain variant codes cannot be used simultaneously.

2) More information available in the Accessories section

S = Included as standard

M = On modification of a stocked motor, or on new manufacture, the number per order may be limited.

P = New manufacture only

R = On request

NA = Not applicable

Code 1)	Variant	Motor size			
		112-132	160-180	200-250	280
Mounting of tachometer; tachometer included					
472	1024 pulse tachometer (Leine & Linde 861) mounted.	P	M	M	M
473	2048 pulse tachometer (Leine & Linde 861) mounted.	P	M	M	M
572	1024 pulse tachometer (L&L 503).	P	M	M	M
573	2048 pulse tachometer (L&L 503).	P	M	M	M
Separate motor cooling & prepared for tachometer; tachometer not included					
474	Separate motor cooling (fan axial, N-end) and prepared for hollow shaft pulse tachometer (Leine & Linde equivalent).	R	M	M	M
574	Separate motor cooling (fan axial, N-end) and prepared for hollow shaft tachometer (L&L 503).	NA	M	M	M
578	Separate motor cooling, IP 44, 400 V, 50 Hz (fan axial, N-end) and prepared for hollow shaft tachometer (L&L 503)	R	M	M	M
Separate motor cooling & tachometer; tachometer not included					
476	Separate motor cooling (fan axial, N-end) and 1024 pulse tachometer (Leine & Linde 861) mounted.	R	M	M	M
477	Separate motor cooling (fan axial, N-end) and 2048 pulse tachometer (Leine & Linde 861) mounted.	R	M	M	M
576	Separate motor cooling (fan axial, N-end) and 1024 pulse tachometer (L&L 503).	NA	M	M	M
577	Separate motor cooling (fan axial, N-end) and 2048 pulse tachometer (L&L 503).	NA	M	M	M
580	Separate motor cooling IP 44, 400 V 50 Hz (fan axial, N-end) and 1024 pulse tachometer (L&L 503).	R	M	M	M
581	Separate motor cooling IP 44, 400 V 50 Hz (fan axial, N-end) and 2084 pulse tachometer (L&L 503).	R	M	M	M
Y/D starting					
117	Terminals for Y/D start at both speeds (two-speed separate windings).	NA	P	P	NA
118	Terminals for Y/D start at high speed (two-speed motors with separate windings).	P	NA	NA	NA

1) Certain variant codes cannot be used simultaneously.

2) More information available in the Accessories section

S = Included as standard

M = On modification of a stocked motor, or on new manufacture, the number per order may be limited.

P = New manufacture only

R = On request

NA = Not applicable

LV Process performance aluminum motors Sizes 112-132

Dimension drawings

Foot-mounted motor IM B 3 (IM 1001), IM 1002

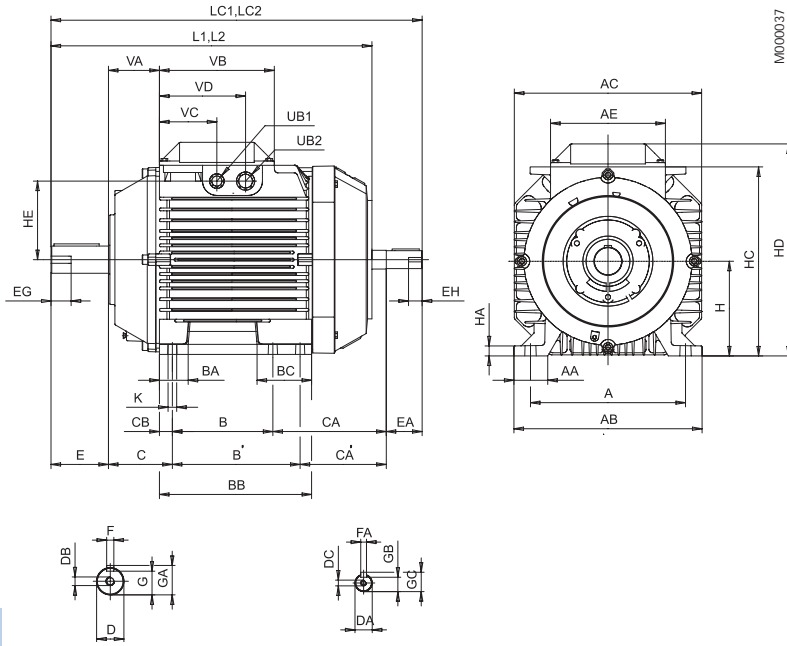

Flange-mounted motor, large flange IM B 5 (IM 3001), IM 3002

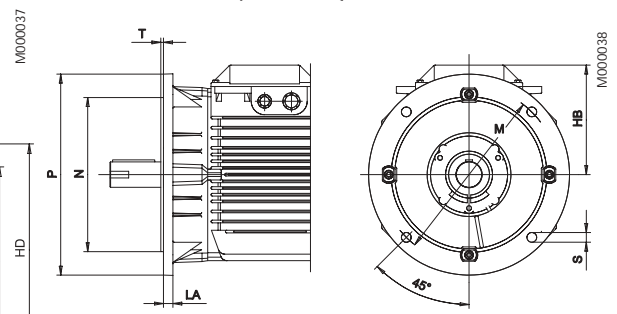

Flange-mounted motor, small flange IM B 14 (IM 3601), IM 3602

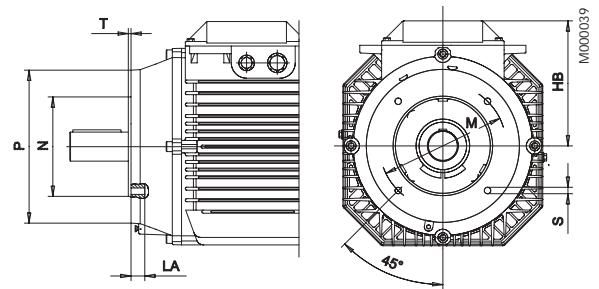

IM B 3 (IM 1001)

Motor size	A	AA	AB	AC	AE	B	B0	BA	BB	BC	C	CA	CA0	CB	D	DA	DB	DC	E ^{B)}	EA	EG	EH	F	FA
112 ¹⁾	190	41	222	221	160	140	-	31	168	31	70	115.5	-	14	28	19	M10	M8	60	40	22	19	8	6
112 ²⁾	190	41	222	221	160	140	-	31	168	31	70	138	-	14	28	19	M10	M8	60	40	22	19	8	6
132 ³⁾	216	47	262	261	160	140	178 ^{A)}	40	212	76	89	158	120	18	38	24	M12	M8	80	50	28	19	10	8
132 ⁴⁾	216	47	262	261	160	140 ^{A)}	178	40	212	76	89	191	153	18	38	24	M12	M8	80	50	28	19	10	8

Motor size	G	GA	GB	GC	H	HA	HC	HD	HE	K	L	L1	L2	LC	LC1	LC2	UB1 ^{C)}	UB2 ^{C)}	VA	VB	VC ^{D)}	VD1	VD2
112 ¹⁾	24	31	15.5	21.5	112	12	226	258	92	12	361 ^{F)}	361 ^{F)}	361 ^{F)}	421.5	421.5	421.5	M20	M25	60	160	80	120	40
112 ²⁾	24	31	15.5	21.5	112	12	226	258	92	12	388 ^{F)}	388 ^{F)}	388 ^{F)}	448	448	448	M20	M25	60	160	80	120	40
132 ³⁾	33	41	20	27	132	14	263.5	295.5	109.5	12	447 ^{G)}	447 ^{G)}	447 ^{G)}	517	517	517	M20	M25	71	160	80	120	40
132 ⁴⁾	33	41	20	27	132	14	263.5	295.5	109.5	12	481.5 ^{G)}	481.5 ^{G)}	481.5 ^{G)}	550	550	550	M20	M25	71	160	80	120	40

IM B 5 (IM 3001)

Motor size	HB	LA	M	N	P	S	T
112 ¹⁾	146	11	215	180	250	14.5	4
112 ²⁾	146	11	215	180	250	14.5	4
132 ³⁾	163.5	14	265	230	300	14.5	4
132 ⁴⁾	163.5	14	265	230	300	14.5	4

IM B14 (IM 3601)

Motor size	HB	LA	M	N	P	S	T
112 ¹⁾	146	20	130	110	160	M8	3.5
112 ²⁾	146	20	130	110	160	M8	3.5
132 ³⁾	163.5	18	165	130	200	M10	3.5
132 ⁴⁾	163.5	18	165	130	200	M10	3.5

Tolerances

A, B ISO js14
 C, CA +2 -2
 D28 ISO j6
 D38 ISO k6
 DA ISO j6
 F, FA ISO h9
 H +0 -0.5
 N ISO j6

¹⁾ M2AA: M-2, M-4. M3AA: M-6, M8
²⁾ all 112 excl 1)
³⁾ M2AA: SA-2, SB-2, S-4, M-4. M3AA: SA-2, S-4, S-6, MA-6, MB-6, S-8, M-8, S-Two-speed
⁴⁾ all 132 excl 3)

^{A)} not acc to IEC.
^{B)} For IM B5 and IM B35: Shoulder of shaft extension and contact surface of flange are in the same plane.
^{C)} Knockout openings.
^{D)} Dimensions to UB1.

^{E)} Dimensions to UB2 (VD1 = right side, VD2 = left side) as viewed from the D-end.
^{F)} For variant code 053 increased by 7.5mm
^{G)} For variant code 053 increased by 5.5mm

Above table gives the main dimensions in mm. For detailed drawings please see our web-pages 'www.abb.com/motors&drives' or contact us.

LV Process performance aluminum motors Sizes 112-132

Dimension drawings

Foot- and flange-mounted motor IM B 35 (IM 2001), IM 2002, large flange

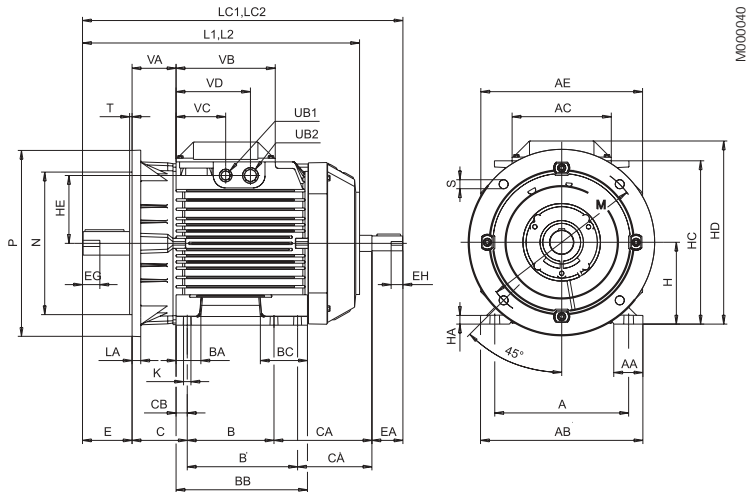

Foot- and flange-mounted motor IM B 34 (IM 2101), IM 2102, small flange

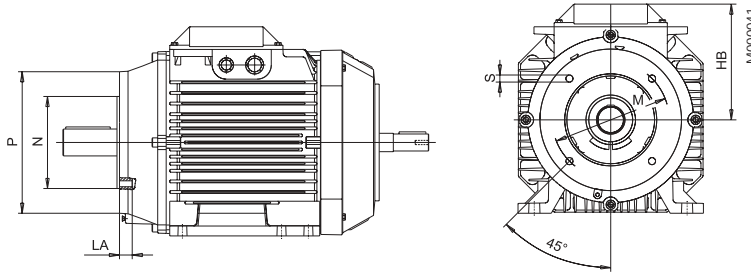

IM B 35 (IM 2001), IM 2002

Motor size	A	AA	AB	AC	AE	B	BØ	BA	BB	BC	C	CA	CAØ	CB	D	DA	DB	DC	E ^{B)}	EA	EG	EH	F	FA
112 ¹⁾	190	41	222	221	160	140	-	31	168	31	70	115.5	-	14	28	19	M10	M8	60	40	22	19	8	6
112 ²⁾	190	41	222	221	160	140	-	31	168	31	70	138	-	14	28	19	M10	M8	60	40	22	19	8	6
132 ³⁾	216	47	262	261	160	140	178 ^{A)}	40	212	76	89	158	120	18	38	24	M12	M8	80	50	28	19	10	8
132 ⁴⁾	216	47	262	261	160	140 ^{A)}	178	40	212	76	89	191	153	18	38	24	M12	M8	80	50	28	19	10	8

Motor size	G	GA	GB	GC	H	HA	HC	HD	HE	K	L	L1	L2	LC	LC1	LC2	UB1 ^{C)}	UB2 ^{C)}	VA	VB	VC ^{D)}	VD1	VD2
112 ¹⁾	24	31	15.5	21.5	112	12	226	258	92	12	361 ^{F)}	361 ^{F)}	361 ^{F)}	421.5	421.5	421.5	M20	M25	60	160	80	120	40
112 ²⁾	24	31	15.5	21.5	112	12	226	258	92	12	388 ^{F)}	388 ^{F)}	388 ^{F)}	448	448	448	M20	M25	60	160	80	120	40
132 ³⁾	33	41	20	27	132	14	263.5	295.5	109.5	12	447 ^{G)}	447 ^{G)}	447 ^{G)}	517	517	517	M20	M25	71	160	80	120	40
132 ⁴⁾	33	41	20	27	132	14	263.5	295.5	109.5	12	481.5 ^{G)}	481.5 ^{G)}	481.5 ^{G)}	550	550	550	M20	M25	71	160	80	120	40

IM B 35 (IM 2001)

Motor size	HB	LA	M	N	P	S	T
112 ¹⁾	146	11	215	180	250	14.5	4
112 ²⁾	146	11	215	180	250	14.5	4
132 ³⁾	163.5	14	265	230	300	14.5	4
132 ⁴⁾	163.5	14	265	230	300	14.5	4

IM B 34 (IM 2101)

Motor size	HB	LA	M	N	P	S	T
112 ¹⁾	146	20	130	110	160	M8	3.5
112 ²⁾	146	20	130	110	160	M8	3.5
132 ³⁾	163.5	18	165	130	200	M10	3.5
132 ⁴⁾	163.5	18	165	130	200	M10	3.5

Tolerances

A, B ISO js14
 C, CA +2 -2
 D28 ISO j6
 D38 ISO k6
 DA ISO j6
 F, FA ISO h9
 H +0 -0.5
 N ISO j6

- ¹⁾ M2AA: M-2, M-4. M3AA: M-6, M8
²⁾ all 112 excl 1)
³⁾ M2AA: SA-2, SB-2, S-4,
 M-4. M3AA: SA-2, S-4, S-6, MA-6,
 MB-6, S-8, M-8, S-Two-speed
⁴⁾ all 132 excl 3)

- ^{A)} not acc to IEC.
^{B)} For IM B5 and IM B35: Shoulder of shaft extension and contact surface of flange are in the same plane.
^{C)} Knockout openings.
^{D)} Dimensions to UB1.

- ^{E)} Dimensions to UB2 (VD1 = right side, VD2 = left side) as viewed from the D-end.
^{F)} For variant code 053 increased by 7.5mm
^{G)} For variant code 053 increased by 5.5mm

Above table gives the main dimensions in mm.
 For detailed drawings please see our web-pages
www.abb.com/motors&drives or contact us.

LV Process performance aluminum motors Sizes 160-180

Dimension drawings

Foot-mounted motor IM B 3 (IM 1001), IM 1002

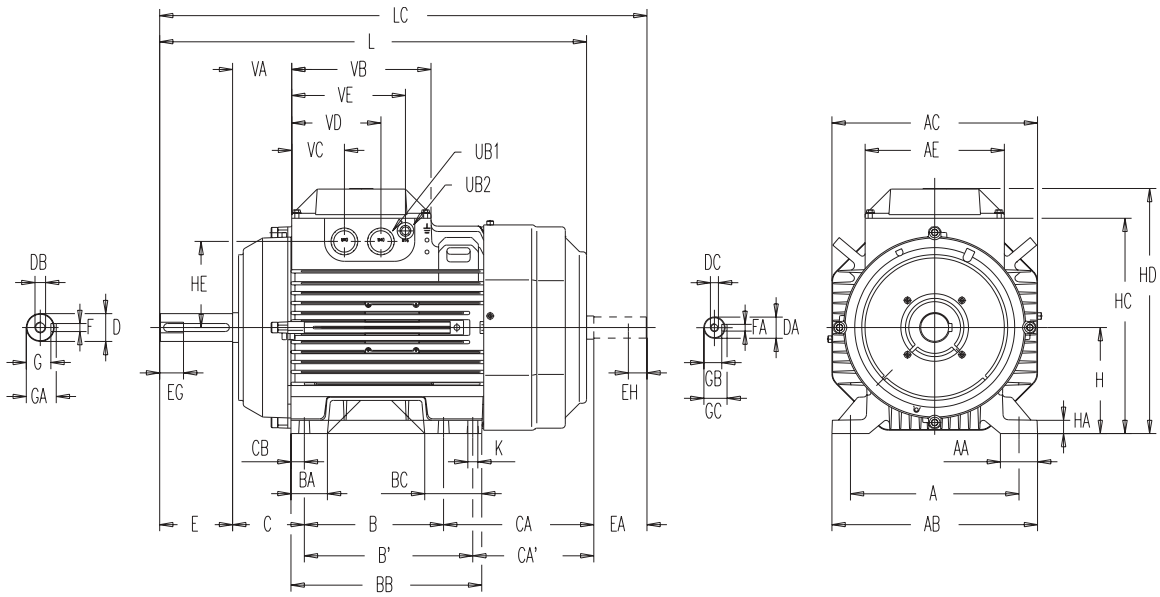

IM B3 (IM 1001), IM 1002

Motor size	A	AA	AB	AC	AE	B ⁷⁾	B0 ⁷⁾	BA	BB	BC	C	CA	CA0	CB	D	DA	DB	DC	E	EA	EG	EH	F ¹⁾
160 ³⁾	254	56	310	310	210	210	254	55	287.5	86	108	185.5	141.5	20	42	32	M16	M12	110	80	36	28	12
160 ⁴⁾	254	56	310	310	210	210	254	55	287.5	86	108	226.5	182.5	20	42	32	M16	M12	110	80	36	28	12
180 ⁵⁾	279	65.5	340	360	210	241	279	58	316	88	121	218	180	25	48	32	M16	M12	110	80	36	28	14
180 ⁶⁾	279	65.5	340	360	210	241	279	58	316	88	121	238	200	25	48	32	M16	M12	110	80	36	28	14

Motor size	FA	G	GA	GB	GC	H	HA	HC	HD	HE	K	L	LC	UB1 ²⁾	UB2 ²⁾	VA	VB	VC	VD	VE
160 ³⁾	10	37	45	27	35	160	20	325	370	130	15	602.5	693.5	2*M40	M16	89	210	84.5	134.5	167.5
160 ⁴⁾	10	37	45	27	35	160	20	325	370	130	15	643.5	734.5	2*M40	M16	89	210	84.5	134.5	167.5
180 ⁵⁾	10	42.5	51.5	27	35	180	20	360	405	145	15	680	770	2*M40	M16	77.5	210	84.5	134.5	167.5
180 ⁶⁾	10	42.5	51.5	27	35	180	20	360	405	145	15	700.5	790	2*M40	M16	77.5	210	84.5	134.5	167.5

Tolerances

A, B ISO js14
 C, CA +2 -2
 D, DA ISO k6
 F, FA ISO h9
 H +0 -0.5

²⁾ Knockout openings.

³⁾ M-2, MA-2, M-4, M-6, M-8, MA-8, L-2, L-4, L-6, MA-2/4, M-2/4, L-2/4, M-4/6, M-4/8, LB-2, LB-4

⁴⁾ L-8, L-4/6, L-4/8, LB-6, LB-8

⁵⁾ M-2, M-4, L-4, L-6, L-8, M-2/4, M-4/6, M-4/8, LB-2

⁶⁾ L-2/4, L-4/6, L-4/8, LB-4, LB-6, LB-8

⁷⁾ 160 M, 180 M: B0 not acc. to IEC

160 L, 180 L: B not acc. to IEC

Above table gives the main dimensions in mm.

For detailed drawings please see our web-pages
 'www.abb.com/motors&drives' or contact us.

LV Process performance aluminum motors Sizes 160-180

Dimension drawings

Flange-mounted motor IM B5 (IM 3001), IM 3002

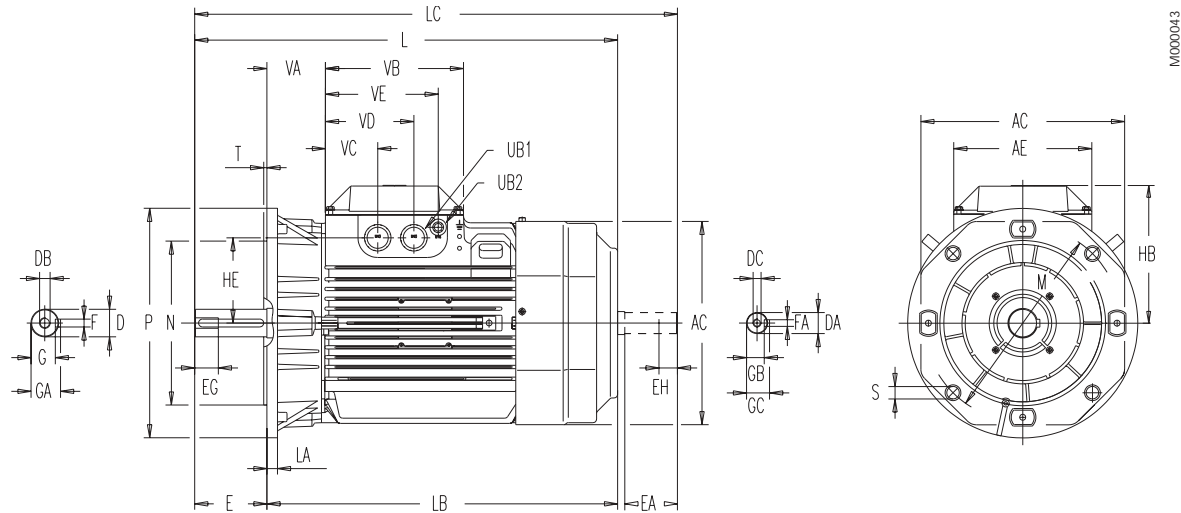

IM B5 (IM 3001), IM 3002

Motor size	AC	AE	D	DA	DB	DC	E ⁷⁾	EA	EG	EH	F ¹⁾	FA	G	GA	GB	GC	HB	HE
160 ³⁾	310	210	42	32	M16	M12	110	80	36	28	12	10	37	45	27	35	210	130
160 ⁴⁾	310	210	42	32	M16	M12	110	80	36	28	12	10	37	45	27	35	210	130
180 ⁵⁾	360	210	48	32	M16	M12	110	80	36	28	14	10	42.5	51.5	27	35	225	145
180 ⁶⁾	360	210	48	32	M16	M12	110	80	36	28	14	10	42.5	51.5	27	35	225	145

Motor size	L	LA	LB	LC	M	N	P	S	T	UB1 ²⁾	UB2 ²⁾	VA	VB	VC	VD	VE
160 ³⁾	602.5	16	492.5	693.5	300	250	350	19	5	2*M40	M16	89	210	79.5	134.5	171.5
160 ⁴⁾	643.5	16	533.5	734.5	300	250	350	19	5	2*M40	M16	89	210	79.5	134.5	171.5
180 ⁵⁾	680	21	570	770	300	250	350	19	5	2*M40	M16	77.5	210	79.5	134.5	171.5
180 ⁶⁾	700.5	21	590.5	790	300	250	350	19	5	2*M40	M16	77.5	210	79.5	134.5	171.5

Tolerances

D, DA ISO k6
F, FA ISO h9
N ISO j6

²⁾ Knockout openings.

³⁾ M-2, MA-2, M-4, M-6, M-8, MA-8, L-2, L-4, L-6, MA-2/4, M-2/4, L-2/4, M-4/6, M-4/8, LB-2, LB-4

⁴⁾ L-8, L-4/6, L-4/8, LB-6, LB-8

⁵⁾ M-2, M-4, L-4, L-6, L-8, M-2/4, M-4/6, M-4/8, LB-2

⁶⁾ L-2/4, L-4/6, L-4/8, L-4, LB-4, LB-6, LB-8

⁷⁾ Shoulder of shaft extension and contact surface of flange are in the same plane.

Above table gives the main dimensions in mm.

For detailed drawings please see our web-pages 'www.abb.com/motors&drives' or contact us.

LV Process performance aluminum motors Sizes 160-180

Dimension drawings

Foot- and flange-mounted motor IM B 35 (IM 2001), IM 2002

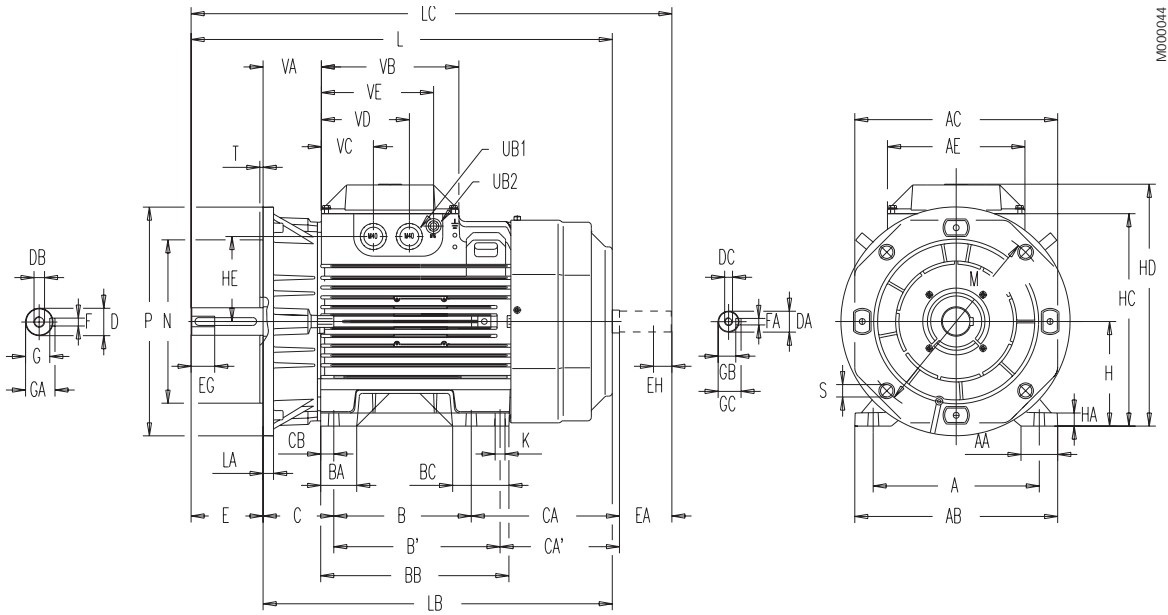

IM B 35 (IM 2001), IM 2002

Motor size	A	AA	AB	AC	AE	B ³⁾	B ³⁾	BA	BB	BC	C	CA	CA ⁴⁾	CB	D	DA	DB	DC
160 ³⁾	254	56	310	310	210	210	254	55	287.5	86	108	185.5	141.5	20	42	32	M16	M12
160 ⁴⁾	254	56	310	310	210	210	254	55	287.5	86	108	226.5	182.5	20	42	32	M16	M12
180 ⁵⁾	279	65.5	340	360	210	241	279	58	316	88	121	218	180	25	48	32	M16	M12
180 ⁶⁾	279	65.5	340	360	210	241	279	58	316	88	121	238	200	25	48	32	M16	M12

Motor size	E ⁷⁾	EA	EG	EH	F	FA	G	GA	GB	GC	H	HA	HB	HC	HD	HE	K	L
160 ³⁾	110	80	36	28	12	10	37	45	27	35	160	20	210	325	370	130	15	602.5
160 ⁴⁾	110	80	36	28	12	10	37	45	27	35	160	20	210	325	370	130	15	643.5
180 ⁵⁾	110	80	36	28	14	10	42.5	51.5	27	35	180	20	225	360	405	145	15	680
180 ⁶⁾	110	80	36	28	14	10	42.5	51.5	27	35	180	20	225	360	405	145	15	700.5

Motor size	LA	LB	LC	M	N	P	S	T	UB1 ²⁾	UB2 ²⁾	VA	VB	VC	VD	VE
160 ³⁾	16	492.5	693.5	300	250	350	19	5	2*M40	M16	89	210	79.5	134.5	171.5
160 ⁴⁾	16	533.5	734.5	300	250	350	19	5	2*M40	M16	89	210	79.5	134.5	171.5
180 ⁵⁾	21	570	770	300	250	350	19	5	2*M40	M16	77.5	210	79.5	134.5	171.5
180 ⁶⁾	21	590.5	790	300	250	350	19	5	2*M40	M16	77.5	210	79.5	134.5	171.5

Tolerances

A, B ISO js14
 C, CA +0 -2
 D, DA ISO k6
 F, FA ISO h9
 H +0 - 0.5
 N ISO j6

²⁾ Knockout openings.

³⁾ M-2, MA-2, M-4, M-6, M-8, MA-8, L-2, L-4, L-6, MA-2/4, M-2/4, L-2/4, M-4/6, M-4/8, LB-2, LB-4.

⁴⁾ L-8, L-4/6, L-4/8, LB-6, LB-8.

⁵⁾ M-2, M-4, L-4, L-6, L-8, M-2/4, M-4/6, M-4/8, LB-2.

⁶⁾ L-2/4, L-4/6, L-4/8, L-4, LB-4, LB-6, LB-8.

⁷⁾ Shoulder of shaft extension and contact surface of flange are in the same plan.

⁸⁾ 160 M, 180 M: B³⁾ not acc. to IEC.

160 L, 180 L: B not acc. to IEC.

Above table gives the main dimensions in mm.

For detailed drawings please see our web-pages
 'www.abb.com/motors&drives' or contact us.

LV Process performance aluminum motors Sizes 200-225

Dimension drawings

Foot-mounted motor IM B3 (IM 1001), IM 1002

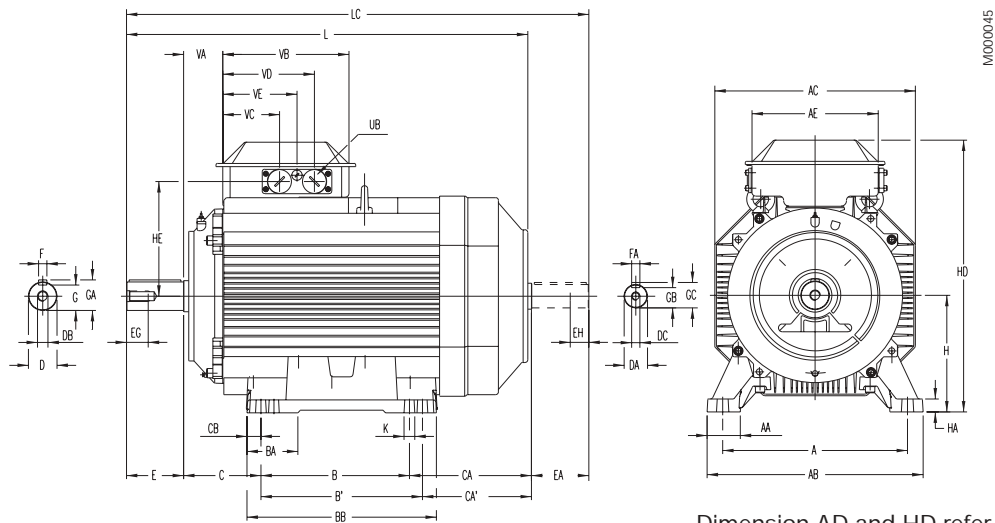

Dimension AD and HD refer to side mounted terminal box, see page 115.

IM B3 (IM 1001), IM 1002

Motor size	A	AA	AB	AC	AE	B	B ⁰	BA	BB	C	CA	CA ⁰	CB	D	DA	DB	DC	E ^{B)}	EA	EG	EH	F	FA
200 ¹⁾	318	64	380	386	243	267	305	98	365	133	273	235	30	55	45	M20	M16	110	110	42	36	16	14
200 ²⁾	318	64	380	386	243	267	305	98	365	133	313	275	30	55	45	M20	M16	110	110	42	36	16	14
225 ³⁾	356	69	418	425	243	286	311	84	360	149	300	275	24.5	55	55	M20	M20	110	110	42	42	16	16
225 ⁴⁾	356	69	418	425	243	286	311	84	360	149	325	300	24.5	55	55	M20	M20	110	110	42	42	16	16
225 ⁵⁾	356	69	418	425	243	286	311	84	360	149	300	275	24.5	60	55	M20	M20	140	110	42	42	18	16
225 ⁶⁾	356	69	418	425	243	286	311	84	360	149	325	300	24.5	60	55	M20	M20	140	110	42	42	18	16

Motor size	G	GA	GB	GC	H	HA	HD	HE	K	L	LC	UB ^{A)}	VA	VB	VC	VD	VE
200 ¹⁾	49	59	39.5	48.5	200	25	533	240	18	774	893	2xFL21	75.5	243	81.5	171.5	126.5
200 ²⁾	49	59	39.5	48.5	200	25	533	240	18	814	933	2xFL21	75.5	243	81.5	171.5	126.5
225 ³⁾	49	59	49	59	225	25	578	260.5	18	836	955	2xFL21	93.5	243	81.5	171.5	126.5
225 ⁴⁾	49	59	49	59	225	25	578	260.5	18	861	980	2xFL21	93.5	243	81.5	171.5	126.5
225 ⁵⁾	53	64	49	59	225	25	578	260.5	18	866	985	2xFL21	93.5	243	81.5	171.5	126.5
225 ⁶⁾	53	64	49	59	225	25	578	260.5	18	891	1100	2xFL21	93.5	243	81.5	171.5	126.5

Tolerances

A, B	ISO js14
C, CA	+0 -2
D 55-65	ISO m6
DA 45-55	ISO k6
F, FA	ISO h9
H	+0 -0.5
N	ISO j6

- 1) all 200 excl ²⁾
- 2) MLD-2, MLC-4
- 3) SMB-2, SMC-2, SM_-2/4
- 4) SMD-2,
- 5) all 225 excl ^{3) 4) 6)}
- 6) SMD-4

- A) Flange opening FL21: 2 x M63 + M16
- B) For IM B5 and IM B35: Shoulder of shaft extension and contact surface of flange are in the same plane.

Above table gives the main dimensions in mm.
For detailed drawings please see our web-pages
'www.abb.com/motors&drives' or contact us.

LV Process performance aluminum motors Sizes 200-225

Dimension drawings

Flange-mounted motor IM B5 (IM 3001), IM 3002

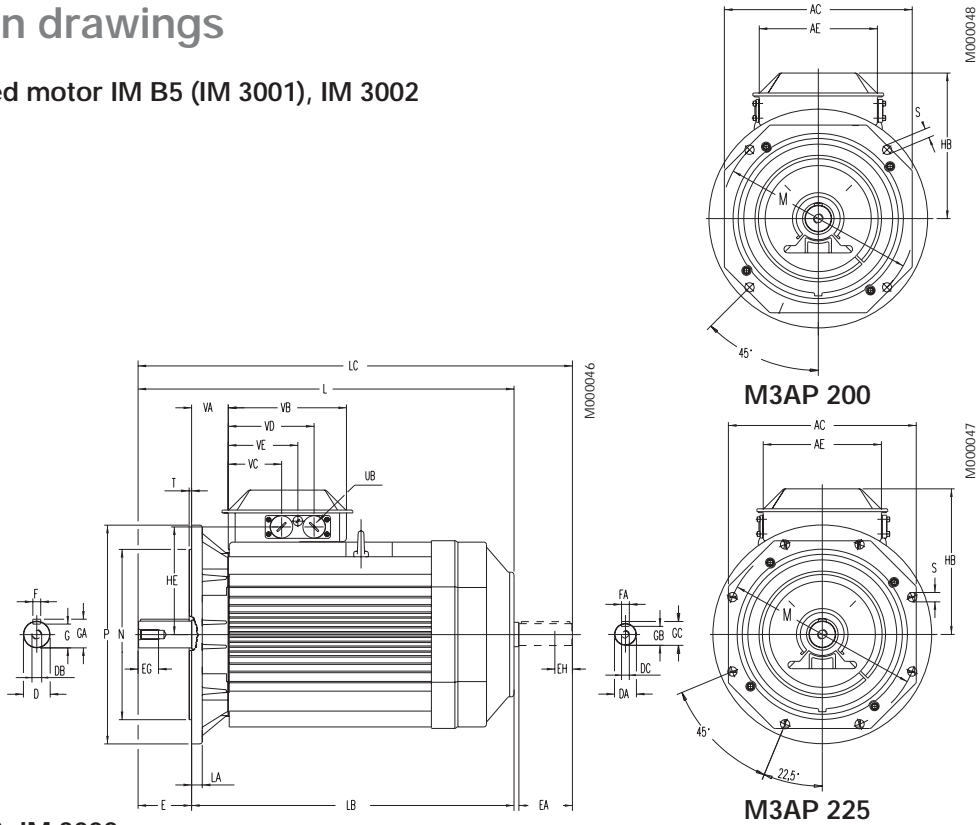

IM B5 (IM 3001), IM 3002

Motor size	AC	AE	D	DA	DB	DC	E ^{B)}	EA	EG	EH	F	FA	G	GA	GB	GC	HB	HE
200 ¹⁾	386	243	55	45	M20	M16	110	110	42	36	16	14	49	59	39.5	48.5	333	240
200 ²⁾	386	243	55	45	M20	M16	110	110	42	36	16	14	49	59	39.5	48.5	333	240
225 ³⁾	425	243	55	55	M20	M20	110	110	42	42	16	16	49	59	49	59	353	260.5
225 ⁴⁾	425	243	55	55	M20	M20	110	110	42	42	16	16	49	59	49	59	353	260.5
225 ⁵⁾	425	243	60	55	M20	M20	140	110	42	42	18	16	53	64	49	59	353	260.5
225 ⁶⁾	425	243	60	55	M20	M20	140	110	42	42	18	16	53	64	49	59	353	260.5

Motor size	L	LA	LB	LC	M	N	P	S	T	UB ^{A)}	VA	VB	VC	VD	VE
200 ¹⁾	774	20	664	893	350	300	400	19	5	2xFL21	75.5	243	81.5	171.5	126.5
200 ²⁾	814	20	704	933	350	300	400	19	5	2xFL21	75.5	243	81.5	171.5	126.5
225 ³⁾	836	22	726	955	400	350	450	19	5	2xFL21	93.5	243	81.5	171.5	126.5
225 ⁴⁾	861	22	751	980	400	350	450	19	5	2xFL21	93.5	243	81.5	171.5	126.5
225 ⁵⁾	866	22	726	985	400	350	450	19	5	2xFL21	93.5	243	81.5	171.5	126.5
225 ⁶⁾	891	22	751	1100	400	350	450	19	5	2xFL21	93.5	243	81.5	171.5	126.5

Tolerances

A, B	ISO js14
C, CA	+0 -2
D 55-65	ISO m6
DA 45-55	ISO k6
F, FA	ISO h9
H	+0 -0.5
N	ISO j6

- 1) all 200 excl 2)
- 2) MLD-2, MLC-4
- 3) SMB-2, SMC-2, SM_-2/4
- 4) SMD-2,
- 5) all 225 excl 3) 4) 6)
- 6) SMD-4

- A) Flange opening FL21: 2 x M63 + M16
- B) For IM B5 and IM B35: Shoulder of shaft extension and contact surface of flange are in the same plane.

Above table gives the main dimensions in mm.
For detailed drawings please see our web-pages
'www.abb.com/motors&drives' or contact us.

LV Process performance aluminum motors Sizes 200-225

Dimension drawings

Foot- and flange-mounted motor IM B35 (IM 2001), IM 2002

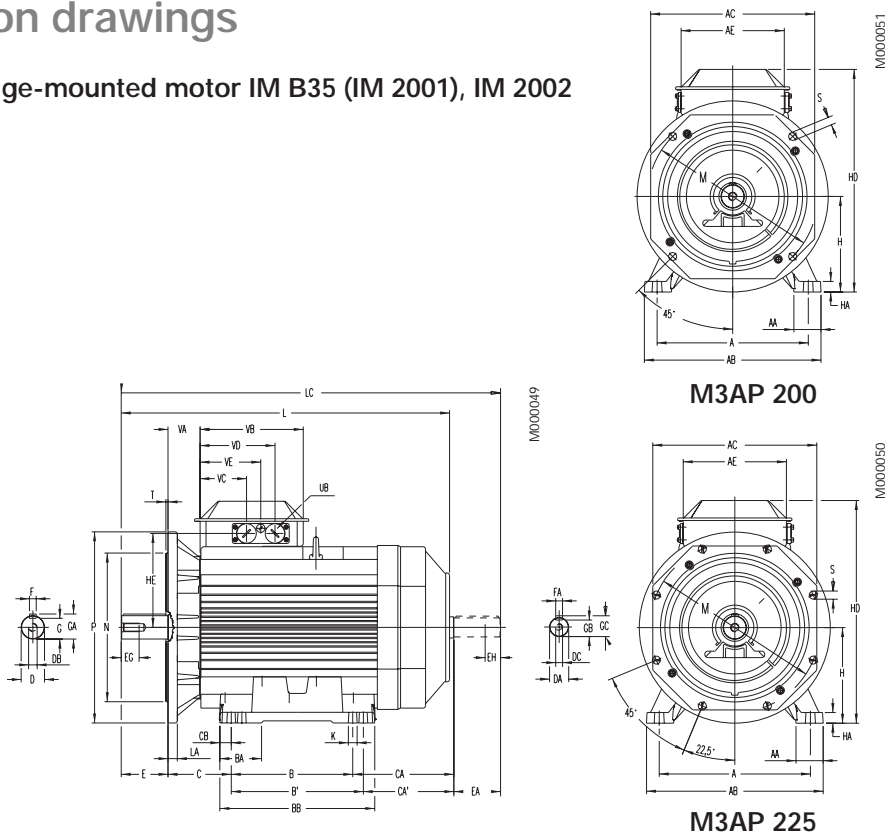

Motor																											
size	A	AA	AB	AC	AE	B	B ⁰	BA	BB	C	CA	CA ⁰	CB	D	DA	DB	DC	E ^{B)}	EA	EG	EH	F	FA	G	GA	GB	GC
200 ¹⁾	318	64	380	386	243	267	305	98	365	133	273	235	30	55	45	M20	M16	110	110	42	36	16	14	49	59	39.5	48.5
200 ²⁾	318	64	380	386	243	267	305	98	365	133	313	275	30	55	45	M20	M16	110	110	42	36	16	14	49	59	39.5	48.5
225 ³⁾	356	69	418	425	243	286	311	84	360	149	300	275	25	55	55	M20	M20	110	110	42	42	16	16	49	59	49	59
225 ⁴⁾	356	69	418	425	243	286	311	84	360	149	325	300	25	55	55	M20	M20	110	110	42	42	16	16	49	59	49	59
225 ⁵⁾	356	69	418	425	243	286	311	84	360	149	300	275	25	60	55	M20	M20	140	110	42	42	18	16	53	64	49	59
225 ⁶⁾	356	69	418	425	243	286	311	84	360	149	325	300	25	60	55	M20	M20	140	110	42	42	18	16	53	64	49	59

Motor																					
size	H	HA	HB ^{A)}	HD ^{A)}	HE	K	L	LA	LB	LC	M	N	P	S	T	UB ^{A)}	VA	VB	VC	VD	VE
200 ¹⁾	200	25	333	533	240	18	774	20	664	893	350	300	400	19	5	2xFL21	75.5	243	81.5	171.5	126.5
200 ²⁾	200	25	333	533	240	18	814	20	704	933	350	300	400	19	5	2xFL21	75.5	243	81.5	171.5	126.5
225 ³⁾	225	25	353	578	260.5	18	836	22	726	955	400	350	450	19	5	2xFL21	93.5	243	81.5	171.5	126.5
225 ⁴⁾	225	25	353	578	260.5	18	861	22	751	980	400	350	450	19	5	2xFL21	93.5	243	81.5	171.5	126.5
225 ⁵⁾	225	25	353	578	260.5	18	866	22	726	985	400	350	450	19	5	2xFL21	93.5	243	81.5	171.5	126.5
225 ⁶⁾	225	25	353	578	260.5	18	891	22	751	1100	400	350	450	19	5	2xFL21	93.5	243	81.5	171.5	126.5

Tolerances

A, B	ISO js14
C, CA	+0 -2
D 55-65	ISO m6
DA 45-55	ISO k6
F, FA	ISO h9
H	+0 -0.5
N	ISO j6

- 1) all 200 excl 2)
- 2) MLD-2, MLC-4
- 3) SMB-2, SMC-2, SM_-2/4
- 4) SMD-2
- 5) all 225 excl 3) 4) 6)
- 6) SMD-4

- A) For extra large flange opening FL21: 2 x M63 + M16
- B) For IM B5 and IM B35: Shoulder of shaft extension and contact surface of flange are in the same plane.

Above table gives the main dimensions in mm.

For detailed drawings please see our web-pages 'www.abb.com/motors&drives' or contact us.

LV Process performance aluminum motors Sizes 250-280

Dimension drawings

Foot-mounted motor IM B3 (IM 1001), IM 1002

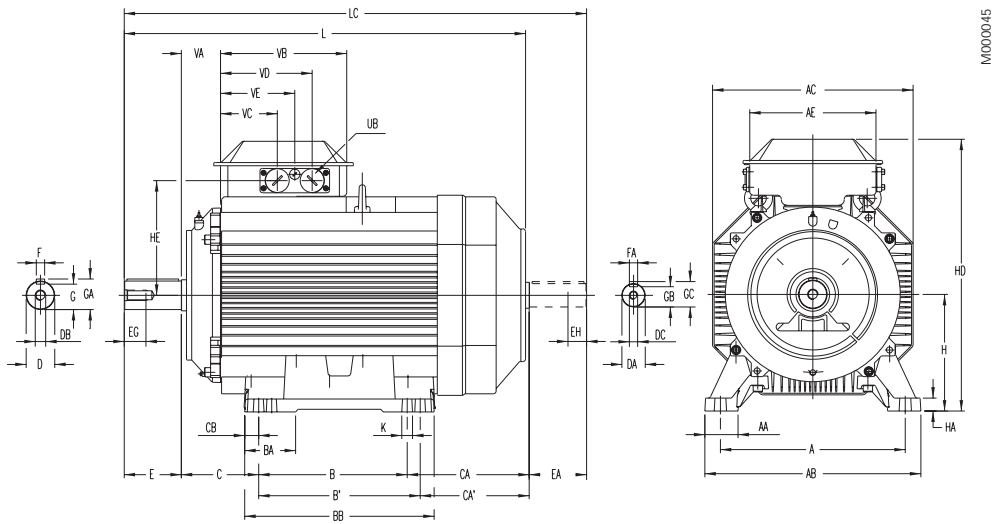

Dimension AD and HD refer to side mounted terminal box, see page 115.

3

IM B3 (IM 1001), IM 1002

Motor size	A	AA	AB	AC	AE	B	B $\bar{0}$	BA	BB	C	CA	CA $\bar{0}$	CB	D	DA	DB	DC	E ^{B)}	EA	EG	EH	F	FA
250 ¹⁾	406	78	474	471	243	311	349	94.5	409	168	263	225	40	60	55	M20	M20	140	110	42	42	18	16
250 ²⁾	406	78	474	471	243	311	349	94.5	409	168	288	250	40	60	55	M20	M20	140	110	42	42	18	16
250 ³⁾	406	78	474	471	243	311	349	94.5	409	168	263	225	30	65	55	M20	M20	140	110	42	42	18	16
250 ⁴⁾	406	78	474	471	243	311	349	94.5	409	168	263	225	30	65	55	M20	M20	140	110	42	42	18	16
280 ⁵⁾	457	102.5	525	471	243	368	419	90.5	489	190	184	133	37.5	65	55	M20	M20	140	110	42	42	18	16
280 ⁶⁾	457	102.5	525	471	243	368	419	90.5	489	190	209	158	37.5	65	55	M20	M20	140	110	42	42	18	16
280 ⁷⁾	457	102.5	525	471	243	368	419	90.5	489	190	184	133	37.5	75	55	M20	M20	140	110	42	42	20	16
280 ⁸⁾	457	102.5	525	471	243	368	419	90.5	489	190	209	160	37.5	75	55	M20	M20	140	110	42	42	20	16

Motor size	G	GA	GB	GC	H	HA	HD ^{A)}	HE	K	L	LC	UB	VA	VB	VC ^{A)}	VD ^{A)}	VE ^{A)}
250 ¹⁾	53	64	49	59	250	40	626	283.5	22	875	992	2xFL21	93.5	243	76.5	166.5	121.5
250 ²⁾	53	64	49	59	250	40	626	283.5	22	900	1017	2xFL21	93.5	243	76.5	166.5	121.5
250 ³⁾	58	69	49	59	250	30	626	283.5	22	875	992	2xFL21	93.5	243	76.5	166.5	121.5
250 ⁴⁾	58	69	49	59	250	30	626	283.5	22	900	1017	2xFL21	93.5	243	76.5	166.5	121.5
280 ⁵⁾	58	69	49	59	280	40	656	283.5	24	875	992	2xFL21	93.5	243	76.5	166.5	121.5
280 ⁶⁾	58	69	49	59	280	40	656	283.5	24	900	1017	2xFL21	93.5	243	76.5	166.5	121.5
280 ⁷⁾	67.5	79.5	49	59	280	40	656	283.5	24	875	992	2xFL21	93.5	243	76.5	166.5	121.5
280 ⁸⁾	67.5	79.5	49	59	280	40	656	283.5	24	900	1017	2xFL21	93.5	243	76.5	166.5	121.5

Tolerances

A, B	ISO js14
C, CA	+0 -2
D 55-65	ISO m6
DA 45-55	ISO k6
F, FA	ISO h9
H	+0 -0.5
N	ISO j6

¹⁾ SMA-2, SMB-2, SMB2/4

²⁾ SMC-2

³⁾ all 250 excl ^{1) 2) 4)}

⁴⁾ SMC-4

⁵⁾ SMA-2

⁶⁾ SMB-2

⁷⁾ SMA-4-8

⁸⁾ SMB-4

^{A)} Flange opening FL21: 2 x M63 + M16

^{B)} For IM B5 and IM B35: Shoulder of shaft extension and contact surface of flange are in the same plane.

Above table gives the main dimensions in mm.
For detailed drawings please see our web-pages
'www.abb.com/motors&drives' or contact us.

LV Process performance aluminum motors Sizes 250-280

Dimension drawings

Flange-mounted motor IM B5 (IM 3001), IM 3002

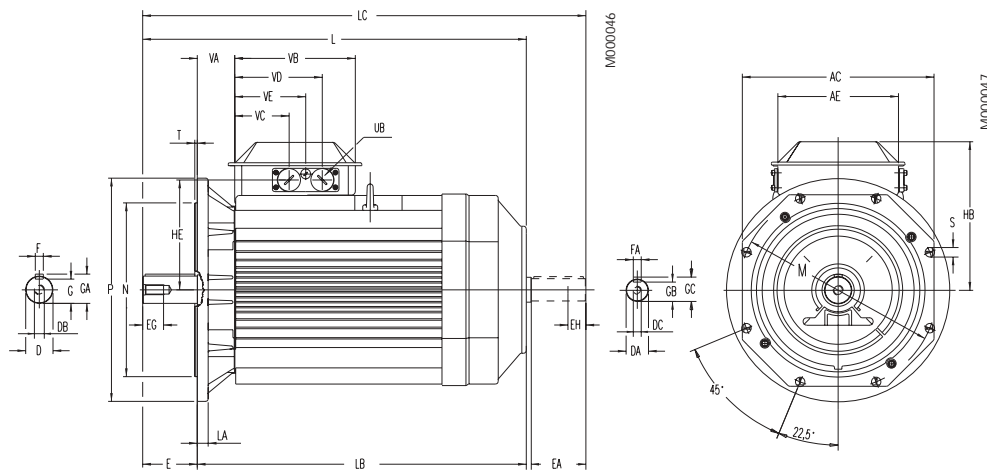

IM B5 (IM 3001), IM 3002

Motor size	AC	AE	D	DA	DB	DC	E ^{B)}	EA	EG	EH	F	FA	G	GA	GB	GC	HB ^{A)}	HE
250 ¹⁾	471	243	60	55	M20	M20	140	110	42	42	18	16	53	64	49	59	376	283.5
250 ²⁾	471	243	60	55	M20	M20	140	110	42	42	18	16	53	64	49	59	376	283.5
250 ³⁾	471	243	65	55	M20	M20	140	110	42	42	18	16	58	69	49	59	376	283.5
250 ⁴⁾	471	243	65	55	M20	M20	140	110	42	42	18	16	58	69	49	59	376	283.5
280 ⁵⁾	471	243	65	55	M20	M20	140	110	42	42	18	16	58	69	49	59	376	283.5
280 ⁶⁾	471	243	65	55	M20	M20	140	110	42	42	18	16	58	69	49	59	376	283.5
280 ⁷⁾	471	243	75	55	M20	M20	140	110	42	42	20	16	67.5	79.5	49	59	376	283.5
280 ⁸⁾	471	243	75	55	M20	M20	140	110	42	42	20	16	67.5	79.5	49	59	376	283.5

Motor size	L	LA	LB	LC	M	N	P	S	T	UB ^{A)}	VA	VB	VC ^{A)}	VD ^{A)}	VE ^{A)}
250 ¹⁾	875	25	735	992	500	450	550	19	5	2xFL21	93.5	243	76.5	166.5	121.5
250 ²⁾	900	25	760	1017	500	450	550	19	5	2xFL21	93.5	243	76.5	166.5	121.5
250 ³⁾	875	25	735	992	500	450	550	19	5	2xFL21	93.5	243	76.5	166.5	121.5
250 ⁴⁾	900	25	760	1017	500	450	550	19	5	2xFL21	93.5	243	76.5	166.5	121.5
280 ⁵⁾	875	25	735	992	500	450	550	19	5	2xFL21	93.5	243	76.5	166.5	121.5
280 ⁶⁾	900	25	760	1017	500	450	550	19	5	2xFL21	93.5	243	76.5	166.5	121.5
280 ⁷⁾	875	25	735	992	500	450	550	19	5	2xFL21	93.5	243	76.5	166.5	121.5
280 ⁸⁾	900	25	760	1017	500	450	550	19	5	2xFL21	93.5	243	76.5	166.5	121.5

Tolerances

A, B	ISO js14
C, CA	+0 -2
D 55-65	ISO m6
DA 45-55	ISO k6
F, FA	ISO h9
H	+0 -0.5
N	ISO j6

- 1) SMA-2, SMB-2, SMB2/4
- 2) SMC-2
- 3) all 250 excl^{1) 2) 4)}
- 4) SMC-4
- 5) SMA-2
- 6) SMB-2
- 7) SMA-4-8
- 8) SMB-4

- A) Flange opening FL21: 2 x M63 + M16
- B) For IM B5 and IM B35: Shoulder of shaft extension and contact surface of flange are in the same plane.

Above table gives the main dimensions in mm.
For detailed drawings please see our web-pages
'www.abb.com/motors&drives' or contact us.

LV Process performance aluminum motors Sizes 250-280

Dimension drawings

Foot- and flange-mounted motor IM B35 (IM 2001), IM 2002

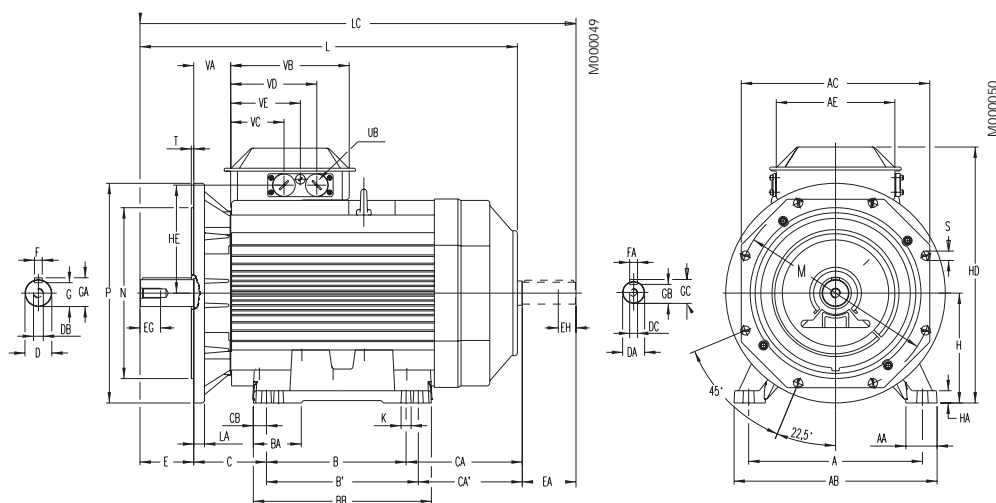

3

IM B35 (IM 2001), IM 2002

Motor size	A	AA	AB	AC	AE	B	B ⁰	BA	BB	C	CA	CA ⁰	CB	D	DA	DB	DC	E ^{B)}	EA	EG	EH	F	FA	G	GA	GB	GC
250 ¹⁾	406	78	474	471	243	311	349	94.5	409	168	263	225	40	60	55	M20	M20	140	110	42	42	18	16	53	64	49	59
250 ²⁾	406	78	474	471	243	311	349	94.5	409	168	288	250	40	60	55	M20	M20	140	110	42	42	18	16	53	64	49	59
250 ³⁾	406	78	474	471	243	311	349	94.5	409	168	263	225	30	65	55	M20	M20	140	110	42	42	18	16	58	69	49	59
250 ⁴⁾	406	78	474	471	243	311	349	94.5	409	168	263	225	30	65	55	M20	M20	140	110	42	42	18	16	58	69	49	59
280 ⁵⁾	457	103	525	471	243	368	419	90.5	489	190	184	133	38	65	55	M20	M20	140	110	42	42	18	16	58	69	49	59
280 ⁶⁾	457	103	525	471	243	368	419	90.5	489	190	209	158	38	65	55	M20	M20	140	110	42	42	18	16	58	69	49	59
280 ⁷⁾	457	103	525	471	243	368	419	90.5	489	190	184	133	38	75	55	M20	M20	140	110	42	42	20	16	68	80	49	59
280 ⁸⁾	457	103	525	471	243	368	419	90.5	489	190	209	160	38	75	55	M20	M20	140	110	42	42	20	16	68	80	49	59

Motor size	H	HA	HB ^{A)}	HD ^{A)}	HE	K	L	LA	LB	LC	M	N	P	S	T	UB ^{A)}	VA	VB	VD ^{A)}	VD ^{A)}	VE ^{A)}
250 ¹⁾	250	40	376	626	283.5	22	875	25	735	992	500	450	550	19	5	2xFL21	93.5	243	76.5	166.5	121.5
250 ²⁾	250	40	376	626	283.5	22	900	25	760	1017	500	450	550	19	5	2xFL21	93.5	243	76.5	166.5	121.5
250 ³⁾	250	30	376	626	283.5	22	875	25	735	992	500	450	550	19	5	2xFL21	93.5	243	76.5	166.5	121.5
250 ⁴⁾	250	30	376	626	283.5	22	900	25	760	1017	500	450	550	19	5	2xFL21	93.5	243	76.5	166.5	121.5
280 ⁵⁾	280	40	376	656	283.5	24	875	25	735	992	500	450	550	19	5	2xFL21	93.5	243	76.5	166.5	121.5
280 ⁶⁾	280	40	376	656	283.5	24	900	25	760	1017	500	450	550	19	5	2xFL21	93.5	243	76.5	166.5	121.5
280 ⁷⁾	280	40	376	656	283.5	24	875	25	735	992	500	450	550	19	5	2xFL21	93.5	243	76.5	166.5	121.5
280 ⁸⁾	280	40	376	656	283.5	24	900	25	760	1017	500	450	550	19	5	2xFL21	93.5	243	76.5	166.5	121.5

Tolerances

A, B	ISO js14
C, CA	+0 -2
D 55-65	ISO m6
DA 45-55	ISO k6
F, FA	ISO h9
H	+0 -0.5
N	ISO j6

- 1) SMA-2, SMB-2, SMB24
- 2) SMC-2
- 3) all 250 excl 1) 2) 4)
- 4) SMC-4
- 5) SMA-2
- 6) SMB-2
- 7) SMA-4-8
- 8) SMB-4

^{A)} Flange opening FL21: 2 x M63 + M16

^{B)} For IM B5 and IM B35: Shoulder of shaft extension and contact surface of flange are in the same plane.

Above table gives the main dimensions in mm.
For detailed drawings please see our web-pages
'www.abb.com/motors&drives' or contact us.

Dimensions for terminal boxes

Code 021 Terminal box on left-hand side seen from D-end

Code 180 Terminal box on right-hand side seen from D-end

Motor size	Dimensions	
	AD	HD
200 ML.	300.5	412.5
225 SM.	321	452
250 SM.	344	494
280	376	524

Code 467 Lower than standard terminal box without screw terminals and extended rubber connection cable 2 m.

Motor size	Dimensions		
	AD	HB	HD
112 M		123.5	235.5
132 S		141	273
132 M		141	273
160		211.5	371.5
180		226.5	406.5
200 ML.	248	248	448
225 SM.	269	269	494
250 SM.	292	292	542
280	292	292	572

Accessories

Protective roof and variable speed drives

Protective roof
Variant code 005

Tacho
Variant codes; 472, 473, 572 and 573

Separate cooling with or without tacho
Variant codes; 183, 474, 476, 477, 189, 574, 576 and 577

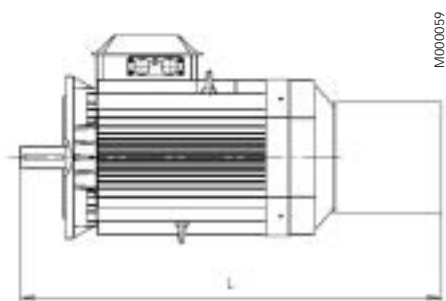
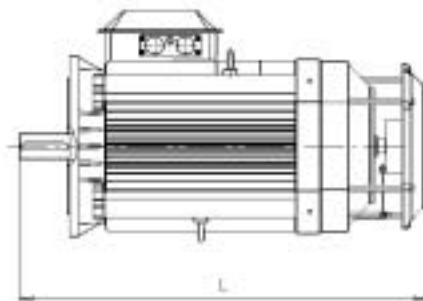
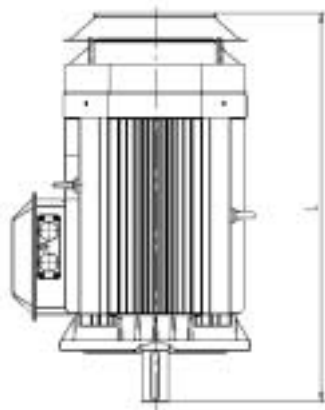

Variant codes;	005	183	189	472, 473 572, 573 576, 577	474, 476 477, 574
Motor size	L	L	L	L	L
112 ¹⁾	400	-	493.5	458.5	543.5
112 ²⁾	428	-	538	487	588
132 ³⁾	484	-	580.5	542	630.5
132 ⁴⁾	522	-	640	580	690
160 ⁵⁾	653.5	1015.5	870.5	697	1015.5
160 ⁶⁾	694.5	1056.5	911.5	738	1056.5
180 ⁷⁾	731	1097	952	774	1097
180 ⁸⁾	751.5	1117.5	972.5	795	1117.5
200 ⁹⁾	825	1234	1089	868	1234
200 ¹⁰⁾	865	1274	1129	908	1274
225 ¹¹⁾	885	1295	1150	930	1295
225 ¹²⁾	910	1320	1175	955	1320
225 ¹³⁾	915	1325	1180	960	1325
225 ¹⁴⁾	940	1350	1205	985	1350
250 ¹⁵⁾	922	1346	1201	969	1346
250 ¹⁶⁾	947	1371	1226	994	1371
280 ¹⁷⁾	922	1346	1201	969	1346
280 ¹⁸⁾	947	1371	1226	994	1371

¹⁾ M-6, M-8,

²⁾ all 112 excl ¹⁾

³⁾ SA-2, S-4, S-6, MA-6, MB-6, S-8, M-8, S-Two-speed

⁴⁾ all 132 excl ³⁾

⁵⁾ M-2, MA-2, M-4, M-6, M-8, MA-8, L-2, L-4, L-6, MA-2/4, M-2/4, L-2/4, M-4/6, M-4/8, LB-2, LB-4

⁶⁾ L-8, L-4/6, L-4/8, LB-6, LB-8.

⁷⁾ M-2, M-4, L-6, L-8, M-2/4, M-4/6, M-4/8, LB-2

⁸⁾ L-2/4, L-4/6, L-4/8, L-4, LB-4, LB-6, LB-8.

⁹⁾ all 200 excl ¹⁰⁾

¹⁰⁾ MLD-2, MLC-4

¹¹⁾ SMB-2, SMC-2, SM_-2/4

¹²⁾ SMD-2,

¹³⁾ all 225 excl ¹¹⁾ ¹²⁾ ¹⁴⁾

¹⁴⁾ SMD-4

¹⁵⁾ all 250 excl ¹⁶⁾

¹⁶⁾ SMC-2, SMC-4

¹⁷⁾ all 280 excl ¹⁸⁾

¹⁸⁾ SMB-2, SMB-4

Accessories

Slide rails for motor sizes 112 to 280

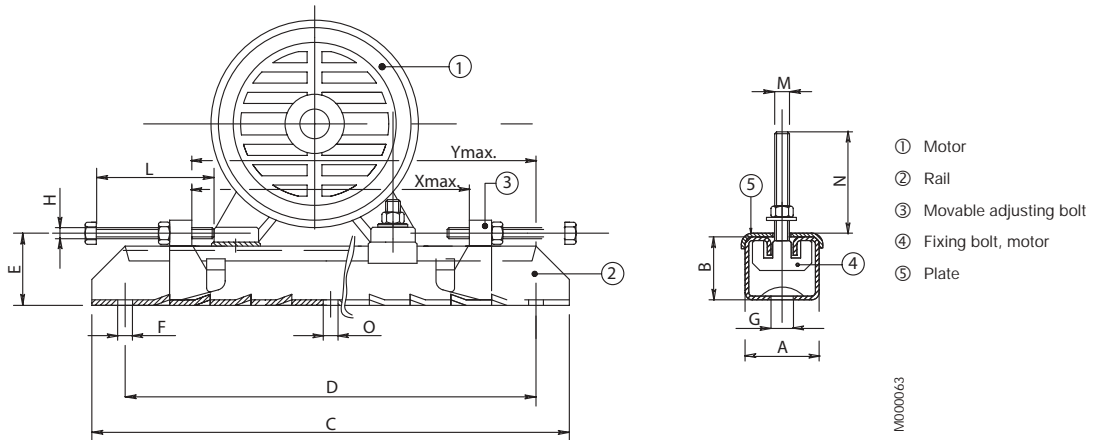

Motor size	Type	Product code	3GZV103001-														Weight
			A	B	C	D	E	F	G	H	L	M	N	O	Xmax	Ymax	kg
112-132	TT132/10	-12	65	40	530	480	52	17	26	M12	120	M10	45	-	360	420	7.8
160-180	TT180/12	-14	75	42	700	630	57	17	26	M12	120	M12	50	-	520	580	12.0
200-225	TT225/16	-15	82	50	864	800	68	17	27	M16	140	M16	65	17	670	740	20.4
250-280	TT280/20	-16	116	70	1072	1000	90	20	27	M18	150	M20	80	20	870	940	43.0

Each set includes two complete slide rails including screw for mounting the motor on the rails. Screws for mounting the rails on the foundation are not included. Slide rails are supplied with unmachined lower surfaces and should, prior to tightening down, be supported in a suitable manner.

LV Process performance aluminum motors in brief, basic design

Size		112	132	160	180	200	225	250	280	
Stator	Material	Die cast aluminum alloy.					Extruded aluminum alloy.			
	Paint colour shade	Munsell blue 8B 4.5/3.25 / NCS 4822 B05G / RAL 5014								
	Paint	Polyester powder paint, $\geq 50\mu\text{m}$								
Feet	Material	Aluminum alloy, integrated with stator.				Aluminum alloy, bolted to the stator. ¹⁾ 250-2, cast iron			Cast iron	
Bearing end shields	Material	D-end: Cast iron, N-end: Die cast aluminum			Cast iron					
	Paint color shade	Munsell blue 8B 4.5/3.25 / NCS 4822 B05G / RAL 5014								
	Paint	Polyester powder paint, $\geq 50\mu\text{m}$								
Bearings Single-speed motor	D-end	6306-2Z/C3	6308-2Z/C3	6309-C3	6310-C3	6312/C3	6313/C3	6315/C3	6316/C3 ¹⁾	
	N-end	6206-2Z/C3	6208-2Z/C3	6309-C3	6309-C3	6310/C3	6312/C3	6313/C3	6313/C3	
Bearings Two-speed motor	D-end	6306-2Z/C3	6308-2Z/C3	6309-C3	6310-C3	6312/C3	6313/C3	6315/C3	NA	
	N-end	6206-2Z/C3	6206-2Z/C3 ²⁾	6309-C3	6309-C3	6310/C3	6312/C3	6313/C3		
		¹⁾ 6315/C3 for 2-pole motors		²⁾ 132M - 6208-2Z/C3						
Axially-locked bearings	Inner bearing cover	D-end ¹⁾			D-end					
			¹⁾ Foot motor. A spring washer at the N-end presses the motor towards the D-end.							
Bearing seals	D-end	V-ring			Gamma sealing					
	N-end	Labyrinth seal, except two-speed motors 112-132M, they have outer and inner V-rings.				Outer and inner V-rings.				
Lubrication		Permanently lubricated shielded bearings. Grease for bearing temperatures -40 to +160°C.			Valve lubrication. Grease for bearing temperature -40 to 150°C.					
SPM-nipples		Optional			As standard					
Terminal box	Material	Die cast aluminum alloy, base integrated with stator.				Deep-drawn steel sheet, bolted to stator.				
	Surface treatment	Similar to stator.				Phosphated. Polyester paint.				
	Screws	Steel 5G. Galvanised and yellow chromated.								
Connections	Knock-out openings	2 x (M25 + M20)			2 x (2 x M40 + M16)			2 x FL21		
	Flange-openings							2 x M63		
								1 x M16		
	Screws	M5			M6			M10		
	Max Cu-area mm ²	10			35			70		
Terminal box		Cable lugs, 6 terminals								
Fan	Material	Polypropylene. Reinforced with 20% glass fibre.								
Fan cover	Material	Steel sheet.								
	Surface treatment	Phosphated. Polyester paint.								
Stator winding	Material	Copper.								
	Impregnation	Polyester varnish. Tropicalised.								
	Insulation class	Insulation class F. Temperature rise class B, unless otherwise stated.								
Stator winding temperature sensors		Optional			PTC thermistors, 150°C, 3 in series.					
Rotor winding	Material	Die cast aluminum								
Balancing method		Half key balancing								
Key way		Closed key way								
Drain holes		Drain holes with closable plastic plugs, open on delivery.								
Enclosure		IP 55								
Cooling method		IC 411								



Low Voltage Process Performance Premium Efficiency Cast Iron and Aluminum Motors

Totally enclosed squirrel cage three phase
low voltage motors,
Sizes 112 - 355, 3 to 250 kW



www.abb.com/motors&drives

- > Motors
- >> Low Voltage Motors
- >>> Process Performance Motors

Process performance premium efficiency motors fulfil the process industries demands for robust and energy effective low voltage AC motors where low lifecycle cost is of main importance.

Mechanical design, dimension drawings and other data are the same as process performance cast iron and aluminum motors.

Ordering information.....	118
Technical data.....	119
Mechanical design: cast iron	14
aluminum.....	70
Rating plates: cast iron	24
aluminum.....	80
Variant codes: cast iron	40
aluminum.....	98
Dimension drawings: cast iron.....	46
aluminum.....	102
Accessories: cast iron.....	59
aluminum.....	114
Cast iron motors in brief: cast iron	67
aluminum.....	116

Ordering information

When placing an order, please state the following minimum data in the order, as in example.

The product code of the motor is composed in accordance with the following example.

Motor type	M3BPP 280 SMB
Pole number	2
Mounting arrangement (IM code)	IM B3 (IM 1001)
Rated output	75 kW
Product code	3GBP281220-ADG
Variant codes if needed	

Motor size

A	B	C	D, E, F, G													
M3BPP	280 SMB	3GBP 281 220	- A D G 003 etc.													
			1	2	3	4	5	6	7	8	9	10	11	12	13	14

A	Motor type
B	Motor size
C	Product code
D	Mounting arrangement code
E	Voltage and frequency code
F	Generation code
G	Variant codes

Explanation of the product code:

Positions 1 to 4

3GBPP = Totally enclosed fan cooled squirrel cage motor with cast iron frame

3GAA = Totally enclosed fan cooled squirrel cage motor with aluminium frame

Positions 5 and 6

IEC-frame

11 = 112	22 = 225
13 = 132	25 = 250
16 = 160	28 = 280
18 = 180	31 = 315
20 = 200	35 = 355

Position 7

Speed (Pole pairs)

1	= 2 poles
2	= 4 poles
3	= 6 poles

Position 8 to 10

Serial number

Position 11

- (dash)

Position 12

Mounting arrangement

A	= Foot-mounted, top-mounted terminal box
R	= Foot-mounted, terminal box RHS seen from D-end
L	= Foot-mounted, terminal box LHS seen from D-end
B	= Flange-mounted, large flange
C	= Flange-mounted, small flange (sizes 71 to 112)
H	= Foot- and flange-mounted, terminal box top-mounted
J	= Foot- and flange-mounted, small flange with tapped holes
S	= Foot- and flange-mounted, terminal box RHS seen from D-end
T	= Foot- and flange-mounted, terminal box LHS seen from D-end
V	= Flange-mounted, special flange
F	= Foot- and flange-mounted. Special flange

Position 13

Voltage and frequency code

See table below

Position 14

Generation code

A, B, C...

The product code must be, if needed, followed by variant codes.

Code letters for supplementing the product code - single speed motors

Code letter for voltage and frequency											
Direct start or, with Δ -connection, also Y/ Δ -start											
Motor size	S		D		H	E		F	T	U	X
	50Hz	60 Hz	50 Hz	60 Hz	50 Hz	50 Hz	60 Hz	50 Hz	50 Hz	50 Hz	
112-132	220-240 V Δ	440-480 VY	380-420 V Δ	440-480V Δ	415 V Δ	500 V Δ	575 V Δ	500 VY	660 V Δ	690 V Δ	Other rated voltage, connection or frequency, 690 V maximum
	380-420 VY	-	660-690 VY	-	-	-	-	-	-	-	
160-355	220, 230 V Δ	-	380, 400, 415 V Δ	440V Δ	415 V Δ	500 V Δ	-	500 VY	660 V Δ	690 V Δ	
	380,400,415VY	440VY	660, 690 VY	-	-	-	-	-	-	-	

LV Process performance premium efficiency cast iron motors

Data acc. to IEC 60034-2,
determination of efficiency



IP 55 - IC 411 - Insulation class F - Temperature rise class B

Out-put kW	Motor type	Product code	Efficiency			Power factor cos φ at 100%	Current			Torque			Moment of inertia J = Å GD ²		Sound pressure level LP dB(A)
			Speed r/min	Full load 100%	3/4 load 75%		I _N A	I _s I _N	T _N Nm	T _s T _N	T _{max} T _N	kgm ²	kg		
3000 r/min = 2-poles			400 V 50 Hz			Basic design									
75	M3BPP 280 SMB	3GBP 281 220-¥¥G	2976	95.2	94.8	0.90	126	7.2	241	2.0	2.7	0.9	665	1)	
90	M3BPP 280 SMC	3GBP 281 230-¥¥G	2978	95.7	95.3	0.91	150	8.0	289	2.6	3.0	1.15	725	1)	
110	M3BPP 315 SMB	3GBP 311 220-¥¥G	2982	96.0	95.7	0.89	185	7.5	352	2.1	2.8	1.4	940	1)	
132	M3BPP 315 SMC	3GBP 311 230-¥¥G	2980	96.2	96.0	0.90	221	7.5	423	2.2	2.7	1.7	1025	1)	
160	M3BPP 315 MLA	3GBP 311 410-¥¥G	2978	96.5	96.3	0.90	265	7.5	513	2.2	2.7	2.1	1190	1)	
1500 r/min = 4-poles			400 V 50 Hz			Basic design									
75	M3BPP 280 SMB	3GBP 282 220-¥¥G	1484	95.4	95.2	0.86	132	7.3	483	2.6	2.9	1.5	665	1)	
90	M3BPP 280 SMC	3GBP 282 230-¥¥G	1484	95.6	95.5	0.88	156	7.4	579	2.8	2.8	1.85	725	1)	
110	M3BPP 315 SMB	3GBP 312 220-¥¥G	1488	96.2	96.0	0.86	194	7.5	706	2.3	2.8	2.6	960	1)	
132	M3BPP 315 SMD	3GBP 312 240-¥¥G	1487	96.3	96.2	0.87	228	7.4	848	2.4	2.8	3.2	1065	1)	
160	M3BPP 315 MLB	3GBP 312 420-¥¥G	1486	96.4	96.3	0.87	275	7.2	1028	2.3	2.6	3.9	1220	1)	
200	M3BPP 355 SMA	3GBP 352 210-¥¥G	1490	96.6	96.5	0.87	343	7.1	1282	2.1	2.7	5.9	1610	1)	
250	M3BPP 355 SMB	3GBP 352 220-¥¥G	1491	96.8	96.7	0.87	428	7.9	1601	2.5	2.9	6.9	1780	1)	
1000 r/min = 6-poles			400 V 50 Hz			Basic design									
45	M3BPP 280 SMB	3GBP 283 220-¥¥G	991	94.8	94.7	0.86	80	7.5	434	2.4	2.6	2.2	645	1)	
55	M3BPP 280 SMC	3GBP 283 230-¥¥G	992	95.2	94.9	0.86	98	7.9	530	2.6	2.7	2.85	725	1)	
75	M3BPP 315 SMB	3GBP 313 220-¥¥G	992	95.6	95.5	0.84	135	7.0	722	2.4	2.7	4.1	930	1)	
90	M3BPP 315 SMC	3GBP 313 230-¥¥G	992	95.9	95.8	0.84	161	7.8	866	2.6	2.9	4.9	1000	1)	
110	M3BPP 315 MLA	3GBP 313 410-¥¥G	992	96.0	95.9	0.84	197	7.4	1059	2.6	2.7	5.8	1150	1)	

1) On request

The two bullets in the product code indicate choice of mounting arrangement, voltage and frequency (see ordering information page).

LV Process performance premium efficiency aluminum motors

Data acc. to IEC 60034-2,
determination of efficiency



IP 55 - IC 411 - Insulation class F - Temperature rise class B

Out-put kW	Motor type	Product code	Efficiency			Power factor		Current			Torque			Moment of inertia		Sound pressure level LP
			Speed r/min	Full load 100%	3/4 load 75%	cos φ at 100%	I_N A	I_s A	T_N Nm	T_s Nm	T_{max} Nm	$J = \dot{A} GD^2$ kgm ²	Weight kg			
3000 r/min = 2-poles																
400 V 50 Hz																
4	M3APP 112 M	3GAA 111 022-¥¥CE2	2860	87.6	89.2	0.93	7.1	7.5	13.4	2.6	3.4	0.012	38	63		
5.5	M3APP 132 SA	3GAA 131 023-¥¥CE2	2900	88.6	89.6	0.88	10.3	9.7	18.1	3.8	4.3	0.016	48	69		
7.5	M3APP 132 SB	3GAA 131 024-¥¥CE2	2915	91.0	91.4	0.90	13.3	11.0	24.6	5.1	5.2	0.022	62	69		
11	M3APP 160 MA	3GAA 161 121-¥¥CE2	2935	92.1	92.3	0.90	19.2	7.4	36	2.7	3.1	0.047	95	69		
15	M3APP 160 M	3GAA 161 122-¥¥CE2	2940	92.9	93.1	0.90	26	8.0	49	3.0	3.3	0.053	105	69		
18.5	M3APP 160 L	3GAA 161 123-¥¥CE2	2935	93.2	93.4	0.89	32.5	8.3	60	3.1	3.3	0.058	111	69		
22	M3APP 180 M	3GAA 181 121-¥¥CE2	2945	93.6	93.9	0.91	37.5	7.1	71	2.7	2.9	0.092	150	70		
30	M3APP 200 MLB	3GAA 201 021-¥¥CE2	2950	93.8	93.8	0.90	52	7.9	97	3.0	2.9	0.18	220	72		
37	M3APP 200 MLC	3GAA 201 022-¥¥CE2	2960	94.6	94.6	0.89	64	8.8	120	3.6	3.3	0.19	230	72		
45	M3APP 225 SMC	3GAA 221 021-¥¥CE2	2970	94.7	94.7	0.88	78	6.9	145	2.3	2.9	0.29	285	74		
75	M3APP 250 SMC	3GAA 251 022-¥¥CE2	2965	95.4	95.8	0.93	124	7.5	242	2.3	2.7	0.6	374	75		
1500 r/min = 4-poles																
400 V 50 Hz																
3	M3APP 112 MA	3GAA 112 021-¥¥CE2	1455	87.5	87.8	0.81	6.2	7.9	19.7	2.7	3.7	0.018	39	56		
4	M3APP 112 M	3GAA 112 022-¥¥CE2	1455	87.8	88.4	0.76	8.6	8.5	26.3	3.3	4.3	0.018	39	56		
5.5	M3APP 132 S	3GAA 132 023-¥¥CE2	1460	89.3	90.5	0.84	10.6	7.5	36	2.6	3.1	0.038	54	59		
7.5	M3APP 132 M	3GAA 132 024-¥¥CE2	1450	90.3	90.7	0.87	14	7.8	49	2.2	3.1	0.048	65	59		
11	M3APP 160 M	3GAA 162 121-¥¥CE2	1470	92.0	92.5	0.83	21	7.7	72	3.2	3.2	0.091	105	62		
15	M3APP 160 L	3GAA 162 122-¥¥CE2	1460	92.1	92.5	0.83	28.5	7.6	98	3.3	3.1	0.102	114	62		
18.5	M3APP 180 M	3GAA 182 121-¥¥CE2	1470	93.3	93.9	0.84	34	6.6	121	2.7	2.8	0.191	154	62		
22	M3APP 180 L	3GAA 182 122-¥¥CE2	1475	93.9	94.3	0.84	41	7.8	143	3.1	3.4	0.225	174	62		
30	M3APP 200 MLB	3GAA 202 021-¥¥CE2	1475	94.2	94.4	0.84	55	8.0	194	4.0	3.1	0.34	225	63		
37	M3APP 225 SMB	3GAA 222 021-¥¥CE2	1480	94.3	94.4	0.85	68	7.4	239	2.8	3.0	0.42	255	66		
45	M3APP 225 SMC	3GAA 222 022-¥¥CE2	1480	95.0	95.0	0.86	80	8.0	291	3.8	3.2	0.49	290	66		
55	M3APP 225 SMD	3GAA 222 023-¥¥CE2	1480	95.1	95.1	0.86	98	8.5	355	4.3	3.8	0.56	315	66		
55	M3APP 250 SMB	3GAA 252 021-¥¥CE2	1480	95.1	95.3	0.87	96	7.4	356	3.0	3.1	0.88	364	67		
75	M3APP 250 SMC	3GAA 252 022-¥¥CE2	1480	95.3	95.3	0.85	135	8.2	484	3.2	3.6	0.95	389	66		

The bullets in the product code indicate choice of mounting arrangement, voltage and frequency, generation code (see ordering information page).

LV Process performance premium efficiency aluminum motors

Data acc. to IEC 60034-2, determination of efficiency

IP 55 - IC 411 - Insulation class F - Temperature rise class B

Out-put kW	Motor type	Product code	Efficiency			Speed r/min	Power factor cos φ at: 100%	3/4 load 75%	Current			Torque			Moment of inertia J = Å GD ²		Sound pressure level LP dB(A)
			Full load 100%	3/4 load 75%	Speed				I _N A	I _s I _N	T _N Nm	T _s T _N	T _{max} T _N	kgm ²	kg		
1000 r/min = 6-poles																	
400 V 50 Hz																	
2.2	M3APP	112 M	3GAA	113 022-¥¥CE2	945	83.6	84.2	0.76	5.1	6.0	22.3	2.4	2.9	0.018	38	54	
3	M3APP	132 S	3GAA	133 024-¥¥CE2	965	86.7	87.1	0.79	6.4	7.0	29.8	2.2	2.8	0.038	52	61	
4	M3APP	132 MA	3GAA	133 025-¥¥CE2	960	87.4	88.2	0.80	8.3	7.0	39.8	2.9	2.7	0.045	60	61	
5.5	M3APP	132 MB	3GAA	133 026-¥¥CE2	960	87.0	87.6	0.78	12	7.3	54	3.5	3.0	0.049	65	61	
7.5	M3APP	160 M	3GAA	163 121-¥¥CE2	975	90.7	91.1	0.77	15.6	7.8	74	2.4	3.3	0.107	113	59	
11	M3APP	160 L	3GAA	163 122-¥¥CE2	970	90.9	91.5	0.78	23	6.8	108	2.3	2.8	0.127	128	61	
15	M3APP	180 L	3GAA	183 121-¥¥CE2	970	92.2	92.4	0.75	31	8.3	147	2.8	3.9	0.237	173	59	
18.5	M3APP	200 MLB	3GAA	203 021-¥¥CE2	985	92.4	92.4	0.81	36	8.3	180	3.7	3.3	0.43	205	1)	
22	M3APP	200 MLC	3GAA	203 022-¥¥CE2	985	92.9	93.0	0.82	42	8.3	214	4.0	3.0	0.49	220	1)	
30	M3APP	225 SMC	3GAA	223 021-¥¥CE2	985	93.6	93.8	0.83	56	7.5	291	3.8	2.8	0.75	277	1)	
37	M3APP	250 SMB	3GAA	253 021-¥¥CE2	985	94.4	94.4	0.82	69	7.4	358	3.3	2.8	1.49	349	1)	

¹⁾ On request



Low Voltage Process Performance Motors for High Ambient Temperatures

Totally enclosed squirrel cage three phase low voltage motors, suitable for high ambient temperature up to +90°C
Sizes 112 - 250, 4 to 55 kW



www.abb.com/motors&drives

- > Motors
- >> Low Voltage Motors
- >>> Process Performance Motors

Mechanical design	124
Rating plates	128
Ordering information.....	129
Technical data.....	130
Variant codes	131
Dimension drawings.....	133
Accessories	134
Motors for high ambient temperatures in brief.....	136

General description

ABB motors for demanding environments are made to an entirely new design based on the latest research into some of today's most challenging production processes. Modeled on ABB's proven motor technology/platform, they incorporate many of its tried and tested features, like lower bearing temperatures, longer lubrication intervals, and improved greasing systems. Capable of withstanding temperatures up to 90°C combined with 100% humidity and highly corrosive environments superiority design for the toughest environments.

Motors are constructed in cast iron or aluminium entirely coated with multilayer epoxy surface treatment.

The motors are fully protected against corrosion both inside and outside suitable for metallurgical, brick or glass manufacturing, wood dryer and food industries.

And to give our motors variable speed control capability, we made full use of ABB's know-how and experience as the world's largest supplier of industrial automation systems.

The result is a rugged and reliable motor that will outperform and outlast many custom-designed competitors, at a demonstrably lower operating cost.

Mechanical design

Stator framework and feet for sizes 112 and 132 are made of an extra corrosion resistant aluminum alloy with low copper content. End shields are made of cast iron.

In motor sizes 160 to 250, the motor frames including feet, bearing housing and terminal box are made of

cast iron. Integrally cast feet allow a very rigid mounting and minimal vibration.

Motors can be supplied for foot mounting, flange mounting and combination of these.

Drain holes

Motors that will be operated in very humid or wet environments and especially under intermittent duty should be provided with drain holes. The appropriate IM designation, such as IM 3031, is specified on the basis of the method of mounting the motor.

Motors are provided with closable plastic plugs in the drain holes (see diagram below).

The plugs will be open on delivery. When mounting the motors it should be ensured that the drain holes face downwards.

In the case of vertical mounting, the upper plug must be hammered home completely. In very dusty environments both plugs should be hammered home.

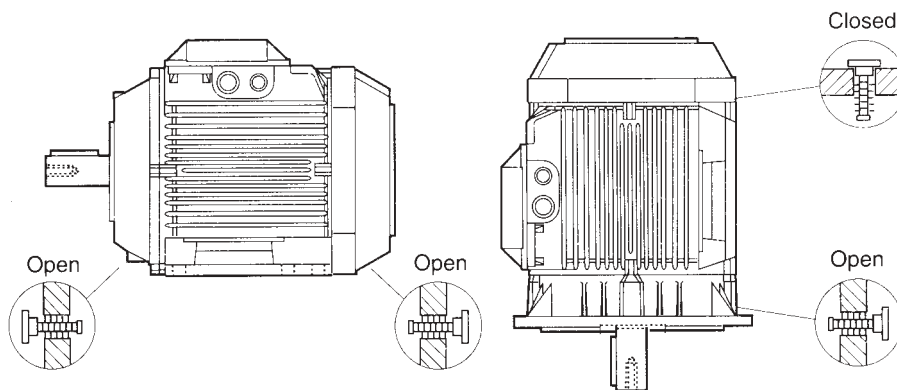

M000015

5

Terminal box

Sizes 112 to 132

The terminal box is made of aluminum alloy and is located on top of the stator. The lower part of the box is integrated with the stator. It is provided with two knock-out openings on each side. Sizes 160-180 also have a third smaller opening. Cable glands are not included.

Sizes 160 to 250

Terminal boxes are mounted on the top of the motor as standard. The terminal box can also be mounted on the left or right side, see ordering information.

The terminal boxes can be turned 4x90°, to allow cable entry from any side of the motor.

Degree of protection of standard terminal box is IP 55

Motors come with connection flanges with tapped cable entries, and can be provided with cable glands as an option.

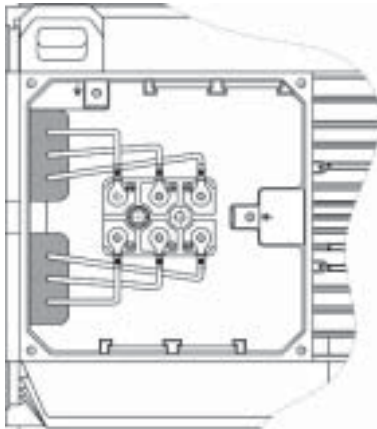

M000310

Terminal box size 112-132



M000313

Terminal box size 160-250

Connections

The terminal block is provided with 6 terminals for connecting Cu-cable. The terminals are marked in accordance with IEC 60034-8.

Connection openings

Motor size	Opening	Metric cable entry	Method of connection	Terminal bolt size	Maximum connectable Cu-cable area, mm ²
112-132	Knock-out opening	2 x (M25 + M20)	Cable lug	M5	10
160-180	Flange	2 x M40	Cable lug	M5	35
200-250	Flange	2 x M40	Cable lug	M10	70

Bearings

The motors are provided with single row deep groove ball bearings. Bearings have C4 clearance, which is needed when the bearing temperature is high. Bearings according to the tables beside.

Basic version with deep groove ball bearings

Motor size	Foot- and flange-mounted motor	
	D-end	N-end
112	6306-C4	6206/C4
132	6308-C4	6208/C4
160	6309/C4	6309/C4
180	6310/C4	6309/C4
200	6312/C4	6310/C4
225	6313/C4	6312/C4
250	6315/C4	6313/C4

Axially-locked bearings

The table below shows which of the motor's bearings are axially locked in the bearing seat. In motor sizes 112 to 250 the locking is done by an inner bearing cover.

Motor size	Foot-mounted motors	Flange-mounted motors	
		Large flange	Small flange
112-132	N-end	N-end	N-end
160-250	N-end	N-end	-

Bearing seals

Motor sizes 112 to 132 are equipped with sealed bearings (2RS). The size and type of seals for sizes 160 to 250 are in accordance with the table below:

Motor size	Number of poles	Standard design		Alternative design	
		Axial seal		Radial seal (DIN 3760)	
		D-end	N-end	Variant code 072	
160	2-12	RB45	V-45A	45x62x8	
180	2-12	RB50	RB45	50x68x8	
200	2-12	RB60	V-50A	60x80x8	Axial seal:
225	2-12	RB65	V-60A	65x85x10	RB45...75 = Gamma-ring
250	2-12	RB75	V-65A	75x95x10	V50...95 = V-ring

Lubrication

Motor sizes 112-132 are provided with shielded bearings. On request, motor sizes 112 to 132 are provided with grease nipples for regreasing, see variant code 041 under the heading "Bearings and lubrications".

Motor sizes 160-250 are provided with grease nipples for regreasing as standard.

Lubrication intervals and grease quantities are specified on a plate on the motor for sizes 160-250 as well as in the installation, operation and maintenance manual supplied with the motor.

Bearing life time and lubrication

The bearings shall be replaced with new bearings after maximum 24000 hours duty or maximum 3 years calendar time.

Lubrication method:

M3APV 112-132 Permanent grease as standard
 M3BPV 160-250 Regreasable bearing as standard
 M3BPV 160-250 Permanent grease bearings as option

Lubrication intervals

ABB follows the L1-principle in defining lubrication interval. That means that 99% of the motors are sure to make the interval time. The lubrication intervals can also be calculated according to the L10-principle, which are normally doubled compared to L1-values. Values available from ABB at request.

The table below gives lubrication intervals according to the L1-principle for different speeds. The values are valid for horizontal mounted motors (B3), and using Shell Albida PPS2 or Mobil Mobilith SHC 220.

For more information, see ABB's instruction for wood dryers.

Frame size	Amount of grease g	1500 r/min				1000 r/min			
		60 °C	70 °C	80 °C	90 °C	60 °C	70 °C	80 °C	90 °C
		Lubrication intervals in duty hours				Lubrication intervals in duty hours			
180	25	3400	2000	1200	700	4000	2500	1500	1000
200	40	2700	1600	900	600	4000	3000	1800	1000
225	50	2500	2000	1400	800	3500	2700	1600	900
250	60	2300	1500	900	600	3300	2300	1300	800

Permissible loading on shaft

Maximum allowed radial and axial forces on the shaft are limited to 50% of the forces for the standard process performance motors intended for duty in maximum 40 °C ambient temperatures. This limitation

is due to the higher temperatures in the bearing and grease. If the forces are higher, information about the maximum force can be supplied on request.

Rating plates

The rating plate is in table form giving the values for speed, current and power factor. Motors with permanently greased bearings have bearing types and grease information on the rating plate.

All rating and lubrication plates are made of stainless steel.

Motors with regreasable bearing have a separate lubrication plate as standard with maintenance information regarding regreasing intervals, grease amount and type of grease can be used.

Motor sizes 112 to 132

ABB		CE	
3~ Motor M3APV 112 M-4		Cl, H	IP 55
3GAA 112 001-ADA, 501		IEC 60034-1	
No.			
V	Hz	r/min	kW
690 Y	50	1435	4,0
400 Δ	50	1435	4,0
Amb 90°C			
6306 2Z/C4		6206 2Z/C4	34 Kg

M000314

Motor sizes 160 to 250

ABB		CE	
3~ Motor M3BPV 160 M 4		IEC 160 M/L 42	
No.			
Ins. cl. H		IP 55	
V	Hz	kW	r/min
690 Y	50	11	1460
400 Δ	50	11	1460
Prod. code 3GBP 162 501-ADA			
Amb 90°C			
6309/C4		6309/C4	115 Kg
3GZV 193 021-9		IEC 60034-1	

M000315

Motor sizes 160 to 250 Lubrication plate

Regreasing intervals in duty hours at amb. temp						
M3BPV	Grease	r/min	60°C	70°C	80°C	90°C
160	25 gr	1000	4000	2500	1500	1000
		1500	3400	2000	1200	700
200	40 gr	1000	4000	3000	1800	1000
		1500	2700	1600	900	600
225	50 gr	1000	3500	2700	1600	900
		1500	2500	2000	1400	800
250	60 gr	1000	3300	2300	1300	800
		1500	2300	1500	900	600

Do not exceed the rated speed.
Regreasing intervals for vertical machines are half of the above values.

The following or equivalent performance greases can be used:	Shell	Albida PPS 2
	Mobil	Mobilith SHC220

See Machine Instructions

M000316

Ordering information

When placing an order, please state the following minimum data in the order, as in example.

The product code of the motor is composed in accordance with the following example.

Motor type	M3BPV 160 M
Pole number	4
Mounting arrangement(IM code)	IM B3 (IM1001)
Rated output	11 kW
Product code	3GBP 162 501-ADE
More variant codes if needed	

Motor size

A	B	C	D, E, F, G															
M3BPV	160 M	3GBP 162 501 - ADE, 199 etc.																
			1	2	3	4	5	6	7	8	9	10	11	12	13	14		
			<p>A Motor type B Motor size C Product code D Code for mounting arrangement E Voltage and frequency code F Generation code followed by variant codes G Variant codes</p>															

Explanation of the product code

Positions 1 to 4

3GAP = Totally enclosed fan cooled squirrel cage process motor with aluminum frame

3GBP = Totally enclosed fan cooled squirrel cage process motor with cast iron frame

Positions 5 and 6

IEC size

11 = 112	20 = 200
13 = 132	22 = 225
16 = 160	25 = 250
18 = 180	

Position 7

Pole pairs

2 = 4 poles
3 = 6 poles

Positions 8 to 10

Running number

Position 11

- (dash)

Position 12

Mounting arrangement

A = Foot-mounted motor

B = Flange-mounted motor.

Large flange with clearance holes.

C = Flange-mounted motor.

Small flange with tapped holes.

F = Foot- and flange-mounted motor.

Special flange.

H = Foot- and flange-mounted motor.

Large flange with clearance holes.

J = Foot- and flange-mounted motor.

Small flange with tapped holes.

N = Flange-mounted (CI ring flange FF)

P = Foot-and flange-mounted motor

(CI ring flange FF)

V = Flange-mounted motor. Special flange.

Position 13

Voltage and frequency: See tables below

Position 14

Version A,B,C... =

Generation code followed by variant codes

Code letters for supplementing the product code - single speed motors

Motor size	Code letter for voltage and frequency Direct start or, with Δ-connection, also Y/Δ-start										X
	S		D		H	E	F	T	U		
	50 Hz	60 Hz	50 Hz	60 Hz	50 Hz	50 Hz	50 Hz	50 Hz	50 Hz	50 Hz	
112-132	220-240 VΔ 380-420 VY	- 440-480 VY	380-420 VΔ 660-690 VY	440-480 VΔ -	415 VΔ	500 VΔ	500 VY	660 VΔ	690 VΔ		Other rated voltage, connection or frequency, 690 V max.
160-250	220, 230 VΔ 380,400,415 VY	- 440 VY	380,400,415VΔ 660, 690 VY	440 VΔ -	415 VΔ	500 VΔ	500 VY	660 VΔ	690 VΔ		

LV Process performance aluminum and cast iron motors for high ambient temperatures

Technical data for totally enclosed squirrel cage three phase motors

IP 55 - IC 411 - Insulation class H, temperature rise class B, ambient temperature up to 90°C

Out-put kW	Motor type	Product code	Efficiency			Power factor			Current			Torque			Moment of inertia		Sound pressure level LP
			Speed r/min	Full load 100%	3/4 load 75%	cos φ at 100%	I_N A	I_s A	I_N A	T_N Nm	T_s Nm	T_{max} Nm	$J = \frac{1}{4} GD^2$ kgm ²	Weight kg			
1500 r/min = 4-poles																	
400 V 50 Hz																	
4	¹⁾ M3APV 112 M	3GAP 112 501-••F	1435	85.3	86.2	0.83	8.2	7.8	26.6	3.0	3.3	0.01	39	56			
5.5	¹⁾ M3APV 132 S	3GAP 132 501-••F	1460	88.0	88.6	0.85	10.7	8.3	36	2.3	3.0	0.03	55	59			
7.5	¹⁾ M3APV 132 M	3GAP 132 502-••F	1455	88.3	89.0	0.85	14.5	6.6	49.2	2.2	3.5	0.04	66	59			
11	¹⁾ M3BPV 160 M	3GBP 162 501-••E	1460	90.7	91.5	0.84	21	7.2	71	3.0	3.1	0.09	115	62			
15	¹⁾ M3BPV 160 L	3GBP 162 502-••E	1455	90.8	91.8	0.84	28.5	7.4	98	3.3	3.2	0.10	127	62			
18.5	¹⁾ M3BPV 180 M	3GBP 182 501-••E	1470	92.0	92.3	0.84	35	6.9	120	2.6	3.1	0.16	175	62			
22	¹⁾ M3BPV 180 L	3GBP 182 502-••E	1470	92.7	93.4	0.84	41	8.4	143	3.6	3.0	0.22	185	63			
30	¹⁾ M3BPV 200 MLB	3GBP 202 501-••E	1475	93.0	93.4	0.85	55	8.2	194	4.2	3.2	0.34	275	63			
37	¹⁾ M3BPV 225 SMB	3GBP 222 501-••E	1480	93.4	93.4	0.84	68	8.4	239	3.9	3.3	0.37	330	66			
45	¹⁾ M3BPV 225 SMC	3GBP 222 502-••E	1475	93.7	93.9	0.87	80	7.4	291	3.5	3.1	0.42	355	66			
55	¹⁾ M3BPV 250 SMB	3GBP 252 001-••E	1480	94.4	94.5	0.86	98	8.7	355	4.2	4.3	0.72	420	67			

¹⁾ When ordering, the following variant code has to be added to the product code: 199 = Extreme heavy duty design.

1000 r/min = 6-poles																	
400 V 50 Hz																	
2.2	¹⁾ M3APV 112 M	3GAP 113 501-••F	935	80.5	80.8	0.78	5.1	5.8	22.5	2.5	2.8	0.01	37	54			
3	¹⁾ M3APV 132 S	3GAP 133 501-••F	965	83.7	83.9	0.78	6.6	7.4	29.7	2.6	3.0	0.03	53	61			
4	¹⁾ M3APV 132 MA	3GAP 133 502-••F	965	85.0	85.7	0.80	8.5	7.3	39.6	3.0	3.0	0.03	61	61			
5.5	¹⁾ M3APV 132 MB	3GAP 133 503-••F	955	84.4	85.3	0.81	11.6	7.1	55	2.0	2.8	0.04	66	61			
7.5	¹⁾ M3BPV 160 M	3GBP 163 501-••E	965	87.7	88.6	0.78	15.7	6.7	74	2.0	3.1	0.08	135	59			
11	¹⁾ M3BPV 160 L	3GBP 163 502-••E	965	89.0	89.7	0.77	23.5	7.1	108	2.4	3.0	0.10	148	59			
15	¹⁾ M3BPV 180 L	3GBP 183 501-••E	970	90.3	91.2	0.79	30.5	6.7	147	2.2	2.9	0.21	185	59			
18.5	¹⁾ M3BPV 200 MLB	3GBP 203 501-••E	980	90.6	91.1	0.82	36	7.1	180	3.5	2.6	0.37	260	63			
22	¹⁾ M3BPV 200 MLC	3GBP 203 502-••E	980	91.5	91.9	0.85	41	8.1	214	4.1	3.1	0.43	275	63			
30	¹⁾ M3BPV 225 SMC	3GBP 223 501-••E	985	92.6	93.0	0.83	57	8.3	290	4.4	3.1	0.64	345	63			
37	¹⁾ M3BPV 250 SMB	3GBP 253 501-••E	985	93.5	93.7	0.84	68	8.0	358	4.0	3.5	1.16	460	63			

¹⁾ When ordering, the following variant code has to be added to the product code: 199 = Extreme heavy duty design.

LV Motors for high ambient temperatures - Variant codes

Code 1)	Variant	Motor size		
		112-132	160-180	200-250
Bearings and lubrication				
040	Heat resistant grease. For bearing temperatures -25 - +150°C.	S	S	S
041	Bearings regreasable via grease nipples.	R	S	S
100	Locked non-drive end	S	S	S
100	Ball bearings with C4-clearance	S	S	S
195	Bearings greased for life	S	R	R
797	Stainless steel SPM nipples.	M	S	S
798	Stainless steel grease nipples.	M	S	S
Branch standard designs				
178	Stainless steel/acid proof bolts.	S	S	S
209	Non-standard voltage or frequency (special winding).	R	R	R
425	Corrosion protected stator and rotor core.* Frame size 71-112, only rotor as standard	S	S	S
Cooling system				
068	Metal fan.	S	M	M
075	Cooling method IC 418 (without fan). Output on request.	M	M	M
792	Metal fasteners for fan cover.	S	S	S
Earthing bolt				
067	External earthing bolt.	M	S	S
Hazardous environments				
See catalogue "Motors for Hazardous Environments", BU/Ex-motors GB", for details.				
Heating elements				
450	Heating element, 100-120 V.	M	M	M
451	Heating element, 200-240 V.	M	M	M
Insulation system				
014	Winding insulation class H.	S	S	S
Marine Motors				
See catalogue "Marine Motors, BU/Marine GB" for details.				
Mounting arrangements				
009	IM 2001 foot/flange mounted, IEC flange, from IM 1001 (B35 from B3).	M	M	M
217	Cast iron D-end shield	S	S	S
232	Cast iron N-end shield	S	S	S
Painting				
114	Special paint colour Orange NCS2070Y60R.	S	S	S
Protection				
784	Gamma-seal at D-end.	S	S	S

1) Certain variant codes cannot be used simultaneously.

S = Included as standard
M = On modification of a stocked motor, or on new manufacture, the number per order may be limited.

P = New manufacture only
R = On request
NA = Not applicable

Code 1)	Variant	Motor size		
		112-132	160-180	200-250
Rating & instruction plates				
003	Individual serial number.	M	S	S
098	Stainless steel rating plate.	S	S	S
100	Stainless steel lubrication plate.	R	S	S
Stator winding temperature sensors				
100	PTC-thermistors (3 in series), 180°C.	S	S	S
Terminal box				
021	Terminal box LHS (seen from D-end).	NA	P	P
180	Terminal box RHS (seen from D-end).	NA	P	P
465	Terminal box top mounted.	S	S	S
467	Lower than standard terminal box and rubber extended cable. Cable length 2 m, included.	P	P	P
Testing				
140	Test confirmation.	M	M	M
145	Type test report from test of identical motor.	M	M	M
146	Type test with report for motor from specific delivery batch.	M	M	M
147	Type test with report for motor from specific delivery batch, customer witnessed.	M	M	M
148	Routine test report.	M	M	M
149	Testing according to separate test specification.	R	R	R
221	Type test and multi-point load test with report for motor from specific delivery batch.	M	M	M
222	Torque/speed curve, type test and multi-point load test with report for motor from specific delivery batch.	M	M	M
760	Vibration level test.	M	M	M
761	Vibration spectrum test.	R	R	R
762	Noise level test.	M	M	M
763	Noise spectrum test.	R	R	R

1) Certain variant codes cannot be used simultaneously.

S = Included as standard
M = On modification of a stocked motor,
or on new manufacture,
the number per order may be limited.

P = New manufacture
only
R = On request
NA = Not applicable

LV Process performance motors for high ambient temperatures

Size 112-250

Dimension drawings

Foot mounted motor IM 1001, B3

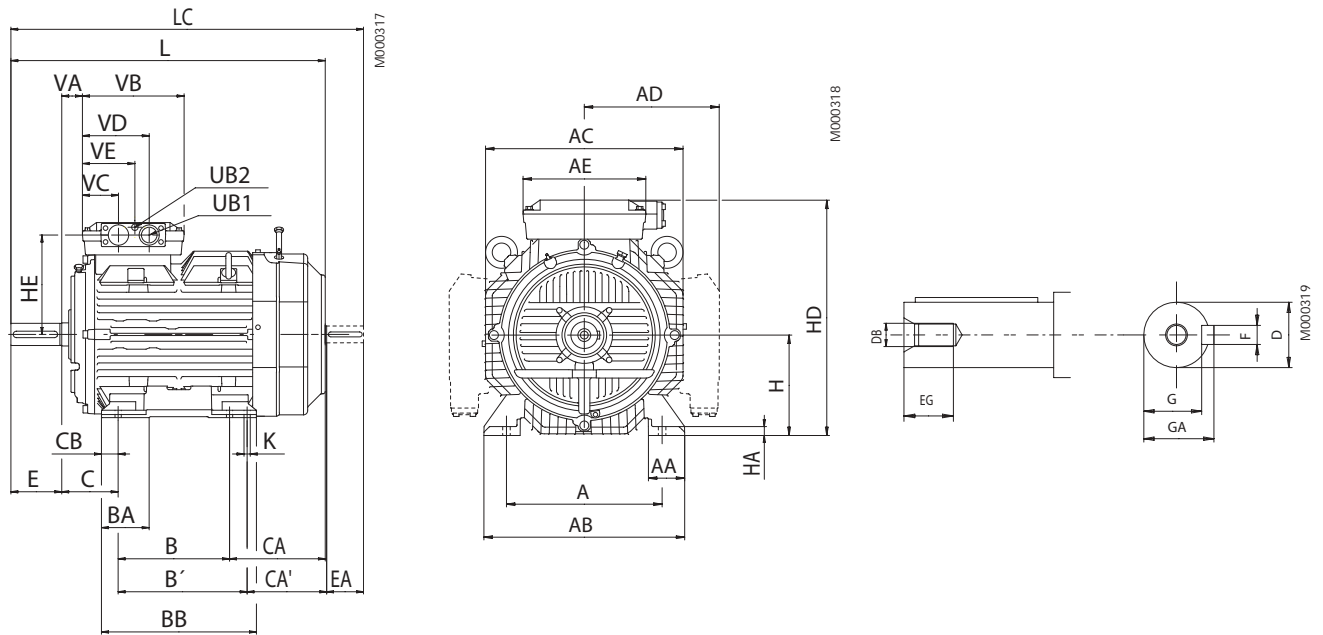

Flange-mounted motor IM 3001, B5

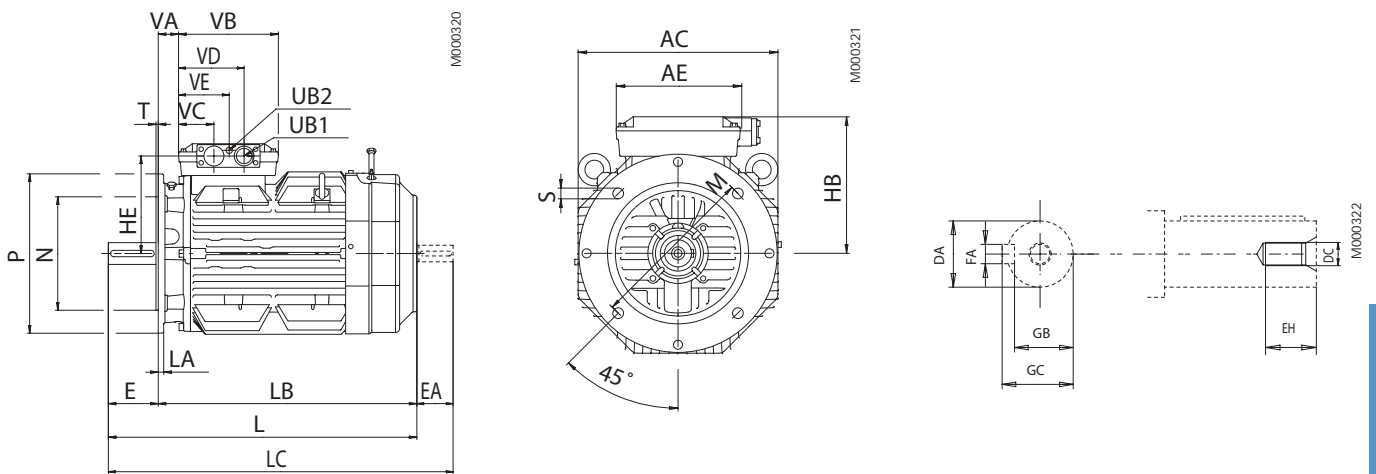

	IM 1001, IM B3 and IM 3001, IM B5					IM 1001, IM B3					IM 3001, IM B5					
Motor size	D	GA	F	E	L max	A	B	B'	C	HD	K	H	M	N	P	S
Aluminum frame																
112	28	31	8	60	388	190	140	-	70	258	12	112	215	180	250	14.5
132	38	41	10	80	481.5	216	140	178	216	140	178	89	265	230	300	14.5
Cast iron frame																
160	42	45	12	110	643.5	254	210	254	108	382	14.5	160	300	250	350	19
180	48	51.5	14	110	700.5	279	241	279	121	422	14.5	180	300	250	350	19
200	55	59	16	110	774	318	267	305	133	506	18.5	200	350	300	400	19
225	60	64	18	140	866	356	286	311	149	552	18.5	225	400	350	450	19
250	65	69	18	140	875	406	311	349	168	605	24	250	500	450	550	19

Accessories

Slide rails for motor sizes 112 to 250

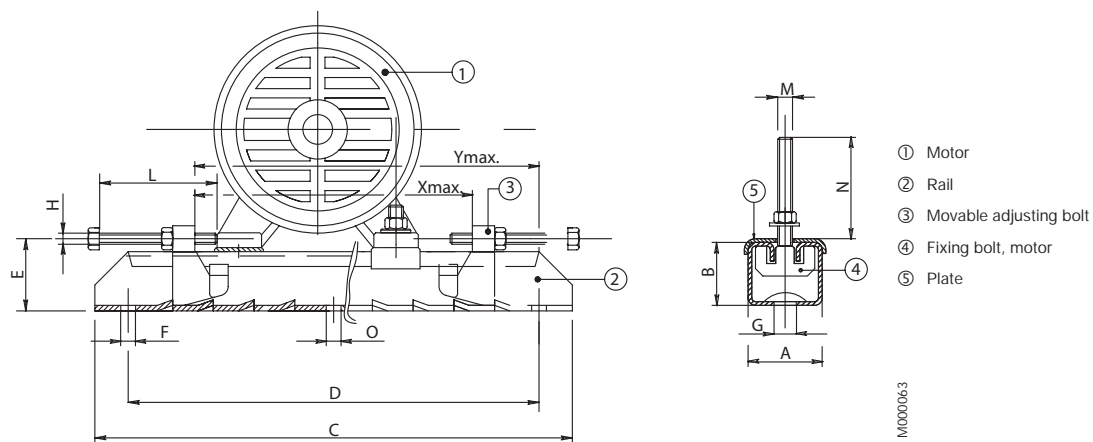

Motor size	Type	Product code 3GZV103001-															Weight kg
			A	B	C	D	E	F	G	H	L	M	N	O	Xmax	Ymax	
112-132	TT132/10	-12	65	40	530	480	52	17	26	M12	120	M10	45	-	360	420	7.8
160-180	TT180/12	-14	75	42	700	630	57	17	26	M12	120	M12	50	-	520	580	12.0
200-225	TT225/16	-15	82	50	864	800	68	17	27	M16	140	M16	65	17	670	740	20.4
250	TT280/20	-16	116	70	1072	1000	90	20	27	M18	150	M20	80	20	870	940	43.0

Each set includes two complete slide rails including screw for mounting the motor on the rails. Screws for mounting the rails on the foundation are not included. Slide rails are supplied with unmachined lower surfaces and should, prior to tightening down, be supported in a suitable manner.

Motors for high ambient temperatures

Hot and Humid - Motors for the toughest environment

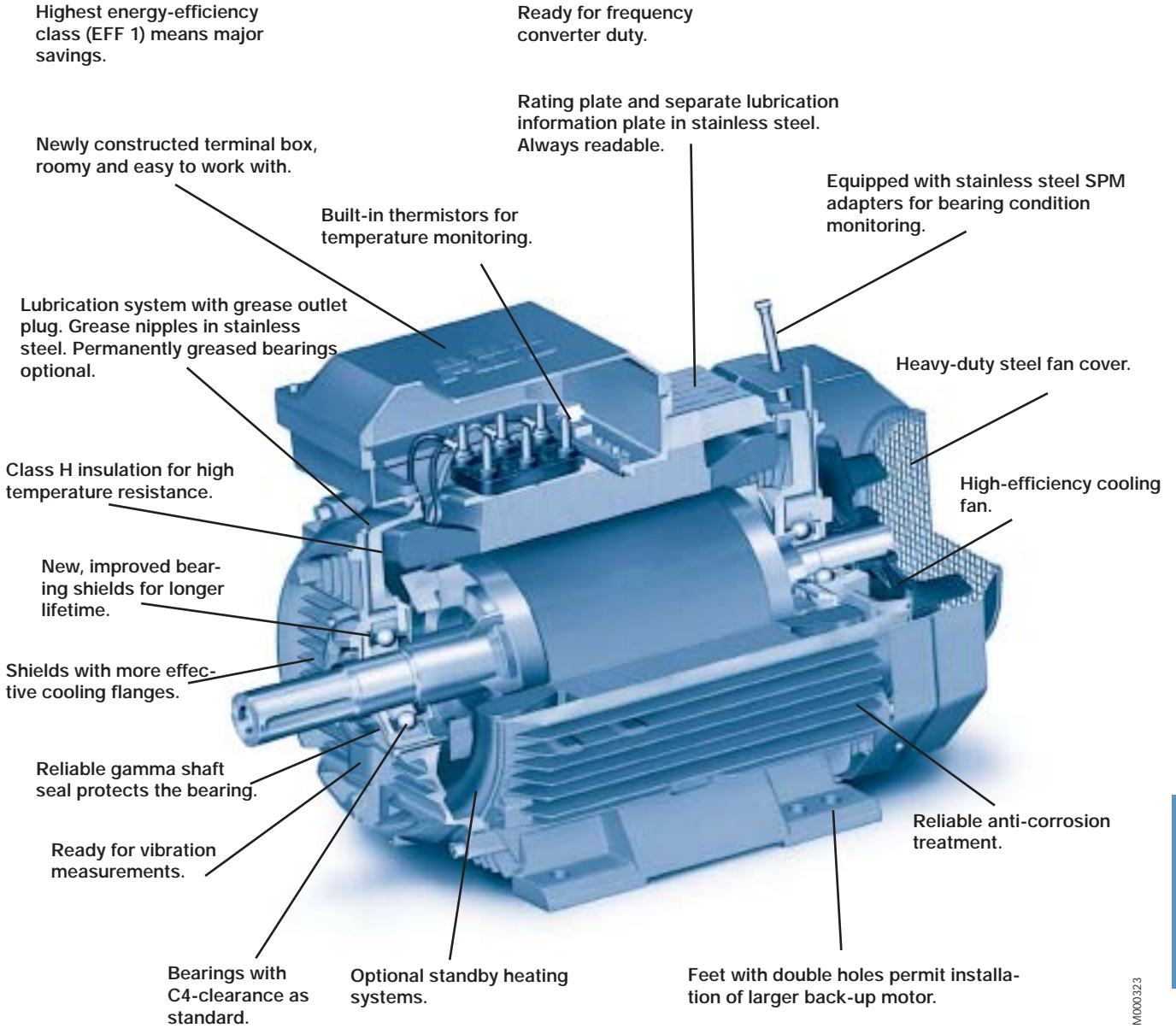

LV Process performance high ambient motors in brief, basic design

Motor size		112	132	160	180	200	225	250
Stator	Material	Die cast aluminum alloy			Cast iron EN-GJL-200/GG 20/GRS 200			
	Paint color shade	Orange NCS2070Y60R						
	Paint thickness	Two-pack epoxy paint, thickness $\geq 70 \mu\text{m}$						
Bearing end shields	Material	Cast iron EN-GJL-150/GG 15/GRS 150						
	Paint color shade	Orange NCS2070Y60R						
	Paint thickness	Two-pack epoxy paint, thickness $\geq 70 \mu\text{m}$						
Bearings	D-end	6306-2Z/C4	6308-2Z/C4	6309/C4	6310/C4	6312/C4	6313/C4	6315/C4
	N-end	6206-2Z/C4	6208-2Z/C4	6309/C4	6309/C4	6310/C4	6312/C4	6313/C4
Axially-locked bearings	Inner bearing cover	N-end						
Bearing seal	D-end	Gamma sealing made of viton						
	N-end	Labyrinth seal			V-ring made of viton			
Lubrication		Permanently lubricated shielded bearings			Regreasable bearings, regreasing stainless steel nipples M6x1			
SPM-adaptors		Optional			As standard with stainless steel adaptors			
Rating plate	Material	Stainless steel, SS-EN 10088, thickness 0,5 mm						
Terminal box	Frame material	Die cast aluminum alloy, base integrated with stator			Cast iron EN-GJL150/GG 15/GRS 150			
	Cover material	Die cast aluminum alloy			Cast iron EN-GJL150/GG 15/GRS 150			
	Cover screw material	Stainless steel						
Connections	Cable entries	2 x (M25 + M20), knock-out openings			2xM40		2xM63	
	Terminals	6 terminals for connection with cable lugs (not included)						
	Cable glands	Available as option			Cable flanges as standard, cable glands as option			
Fan	Material	Aluminum			Glass-fibre reinforced moulded polypropylene			
Fan cover	Material	Steel sheet						
	Paint color shade	Orange NCS2070Y60						
	Paint thickness	Two-pack epoxy paint, thickness $\geq 70 \mu\text{m}$						
Stator winding	Material	Copper						
	Insulation	Insulation class H						
	Winding protection	PTC thermistors, 180 °C, 3 in series						
Rotor winding	Material	Die cast aluminum with corrosion protection painted rotor						
	Balancing method	Half key balancing						
	Key ways	Closed key ways						
Heating elements	On request	25W	25W	25W	25W	50W	50W	50W
Drain holes		Drain holes with plastic plugs, open on delivery						
Enclosure		IP55 with closed plastic plugs						
Cooling method		IC411						



High Voltage Process Performance Cast Iron Motors

Totally enclosed squirrel cage three phase high voltage motors,
Sizes 315 - 450, 110 to 750 kW



www.abb.com/motors&drives

- > Motors
- >> High Voltage Motors
- >>> Process Performance
Cast Iron Motors, 315-450

Mechanical design	138
Ordering information.....	153
Technical data.....	154
Variant codes.....	172
Dimension drawings.....	173
Accessories	176
Construction	178
Cast iron motors in brief.....	179

Mechanical design

This is a standard motor catalogue with limited optional features and accessories. In case you need an

engineered cast iron motor, please contact your local ABB Sales office for further information.

Stator frame

The motor frames including feet and bearing housing are made of cast iron. Terminal box is made of structural steel. Integrally cast feet allow a very rigid mounting and minimal vibration.

Motors can be supplied for foot mounting (horizontal), foot and flange mounting (horizontal) or flange mounting (vertical).

Drain holes

All the high voltage motors are fitted with drain holes and closable plugs. The drain hole plugs are open on delivery and users must ensure that the drain holes face downward when mounting the motors.

For applications with a vertical mounting, the upper plug must be hammered home completely. In very dusty environments, both plugs should be hammered home.

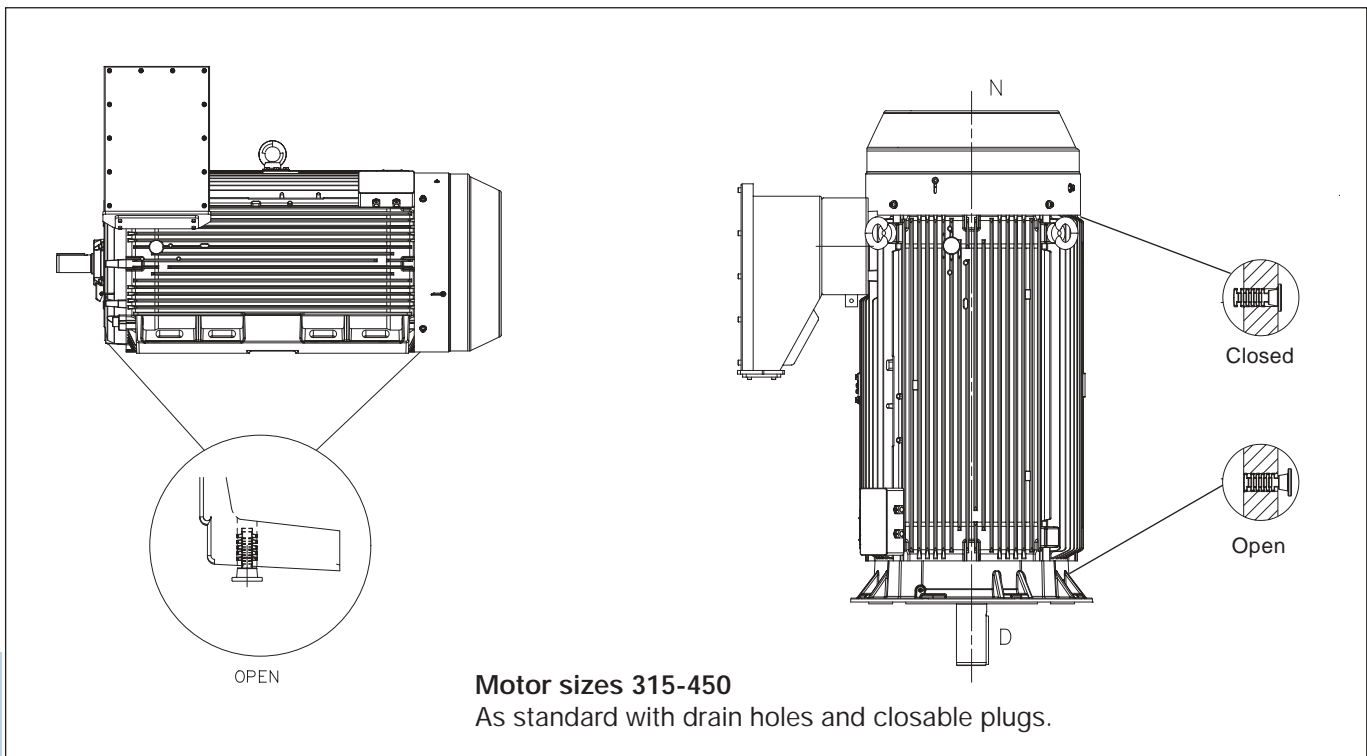

M000241

Terminal boxes

The high voltage terminal box up to 6.6 kV is shown below. The main technical data are listed below.

Technical data:

Voltage (max.)	6.6 kV
Current (max.)	400 A
No of cables (max.)	1 per phase
Cross section of cables (max.)	300 mm ² /cable
Cable gland	blind gland (1 pcs)
Clearance (min.)	60 mm
Creepage (min.)	90 mm
Gross volume	47.3 dm ³
Usable volume	42.1 dm ³
Connection screws	M16 (3 pcs)
Connection nuts tightening torque	40 Nm
Ground connections	M12 (both in- and outside)
Weight	33 kg
Protection	IP 66
Standard	DIN 42962 TEIL 1, A2
Dynamic short circuit current	30 kA rms x 0.25 s/ 75 kA peak

Materials:

Box	welded structural steel (thickness min. 3 mm)
Cable gland plate	steel
Connection screws	Bronze Bz
Isolators	epoxy casting resin or polyurethane resin
Grounding pad	stainless steel

Other features:

- rigid welded construction
- ample size for making connections of supply cables
- box turnable to allow cable entry from left or right side
- box turnable in steps of 90°
- either 3-phase or 1-phase cables can be connected
- pressure relief plate in the bottom of the box in case of an arching short circuit

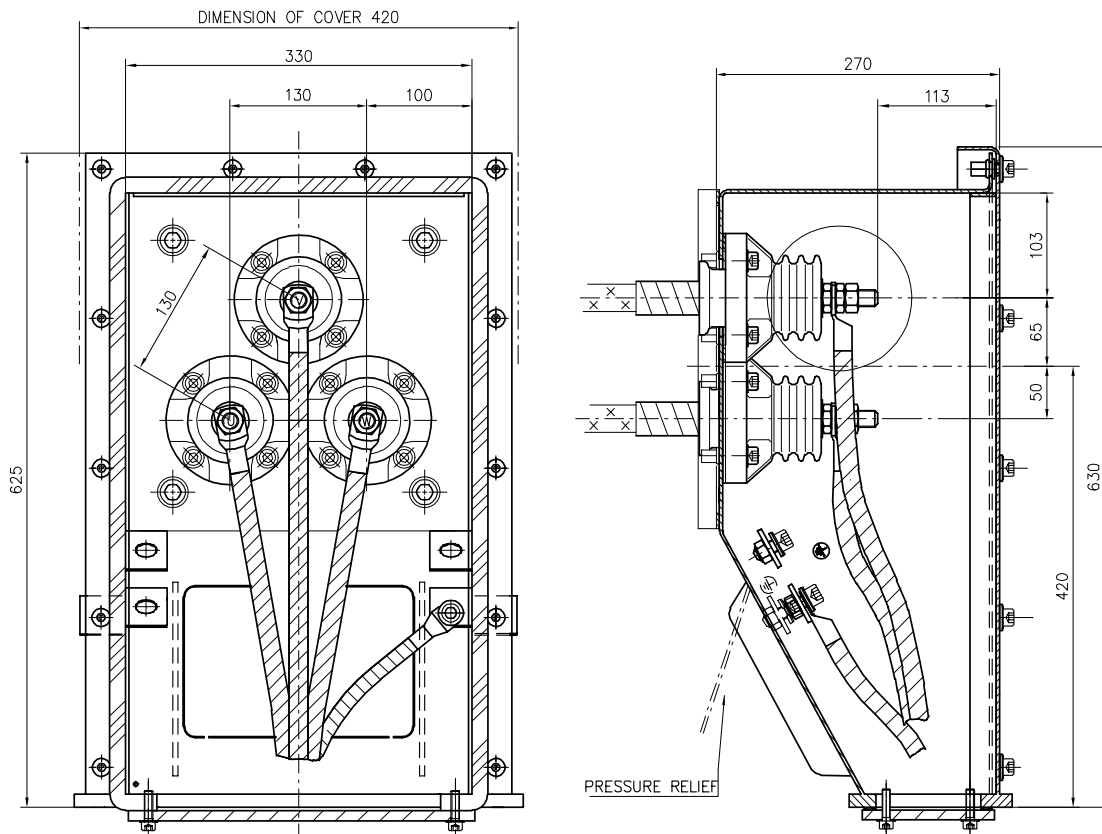

High voltage terminal box up to 6.6 kV.

The high voltage terminal box up to 11 kV is shown below. The main technical data are listed below.

Technical data:

Voltage (max.)	11 kV
Current (max.)	400 A
No of cables (max.)	1 per phase
Cross section of cables (max.)	300 mm ² /cable
Cable gland	blind gland (1 pcs)
Clearance (min.)	110 mm
Creepage (min.)	150mm
Gross volume	122 dm ³
Usable volume	116 dm ³
Connection screws	M16 (3 pcs)
Connection nuts tightening torque	40 Nm
Ground connections	M12 (both in- and outside)
Weight	62 kg
Protection Standard	IP 66 DIN 42962 TEIL 2, C2
Dynamic short circuit current	30 kA rms x 0.25 s/ 75 kA peak

Materials:

Box	welded structural steel (thickness min. 3 mm)
Cable gland plate	steel
Connection screws	Bronze Bz
Isolators	epoxy casting resin or polyurethane resin
Grounding pad	stainless steel

Other features:

- rigid welded construction
- ample size for making connections of supply cables
- box turnable to allow cable entry from left or right side
- box turnable in steps of 90°
- either 3-phase or 1-phase cables can be connected
- pressure relief plate in the bottom of the box in case of an arching short circuit

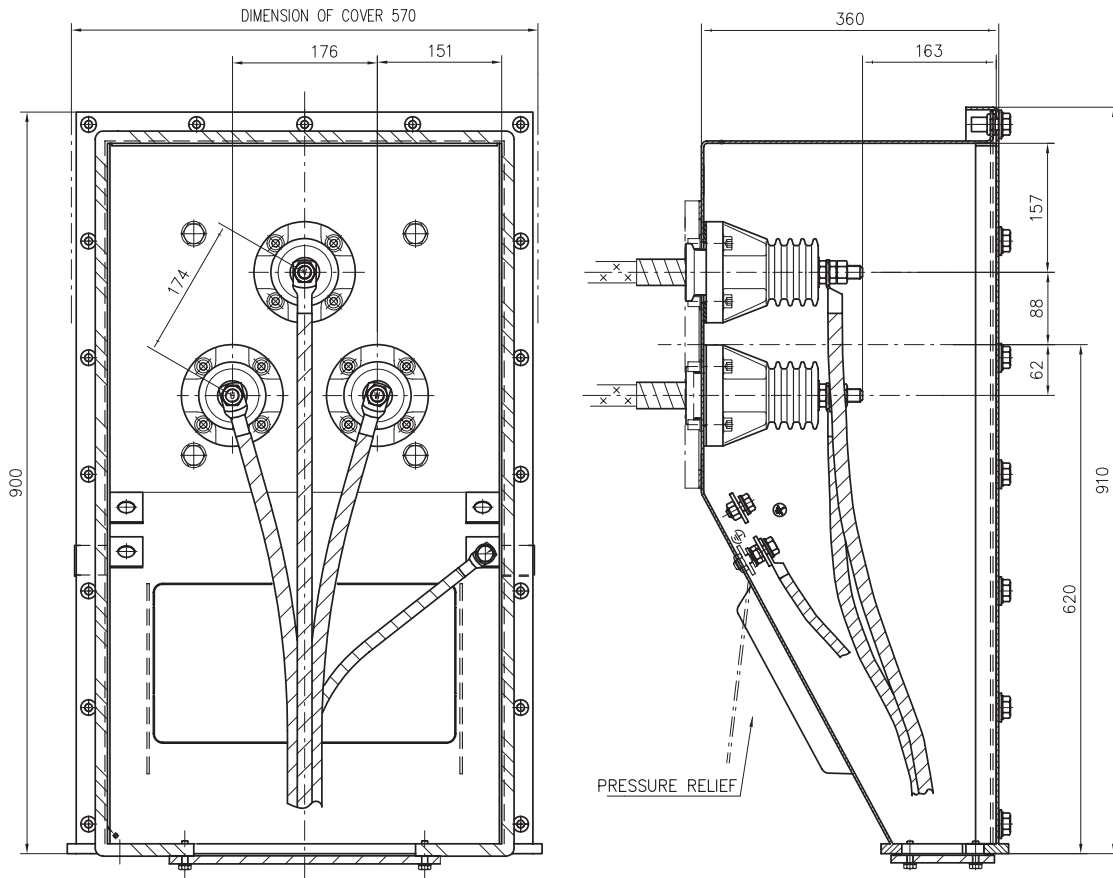

High voltage terminal box up to 11 kV.

The high voltage star point terminal box up to 6.6 kV is shown below (option, variant code 750). The main technical data are listed below.

Technical data:

Voltage (max.)	6.6 kV
Current (max.)	400 A
Cable gland	blind gland (1 pcs)
Creepage (min.)	90 mm
Gross volume	47.3 dm ³
Usable volume	42.1 dm ³
Connection screws	M16 (3 pcs)
Connection nuts tightening torque	40 Nm
Ground connections	M12 (both in- and outside)
Weight	33 kg
Protection	IP 66

Materials:

Box	welded structural steel (thickness min. 3 mm)
Cable gland plate	steel
Connection screws	Bronze Bz
Connection bar	Copper Cu
Isolators	epoxy casting resin or polyurethane resin
Grounding pad	stainless steel

Other features:

- rigid welded construction
- box turnable to left or right side
- box turnable in steps of 90°
- pressure relief plate in the bottom of the box in case of an arching short circuit

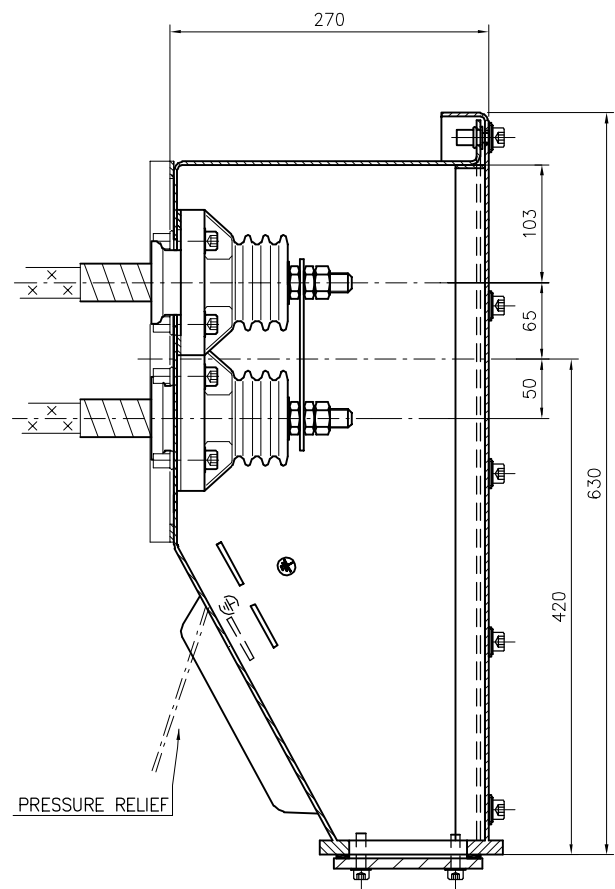
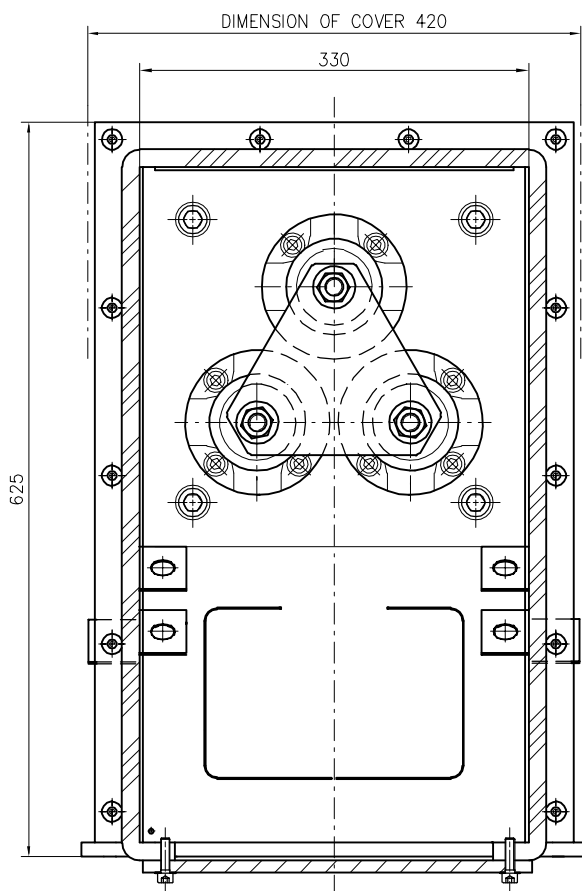

High voltage star point terminal box up to 6.6 kV.

The high voltage star point terminal box up to 11 kV is shown below (option, variant code 750). The main technical data are listed below.

Technical data:

Voltage (max.)	11 kV
Current (max.)	400 A
Cable gland	blind gland (1 pcs)
Creepage (min.)	110 mm
Gross volume	122 dm ³
Usable volume	116 dm ³
Connection screws	M16 (3 pcs)
Connection nuts tightening torque	40 Nm
Ground connections	M12 (both in- and outside)
Weight	62 kg
Protection	IP 66

Materials:

Box	welded structural steel (thickness min. 3 mm)
Cable gland plate	steel
Connection screws	Bronze Bz
Connection bar	Copper Cu
Isolators	epoxy casting resin or polyurethane resin
Grounding pad	stainless steel

Other features:

- rigid welded construction
- box turnable to left or right side
- box turnable in steps of 90°
- pressure relief plate in the bottom of the box in case of an arching short circuit

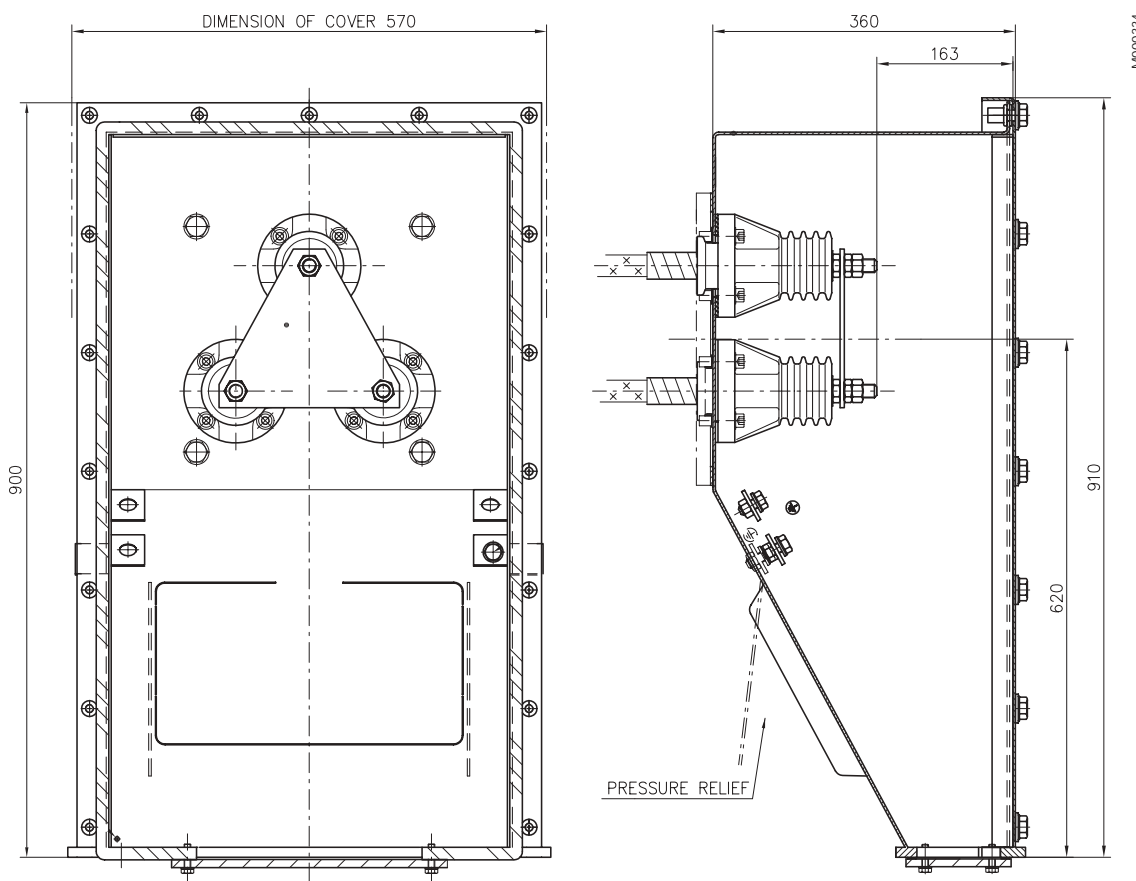

High voltage star point terminal box up to 11 kV.

Star point terminal box (optional)

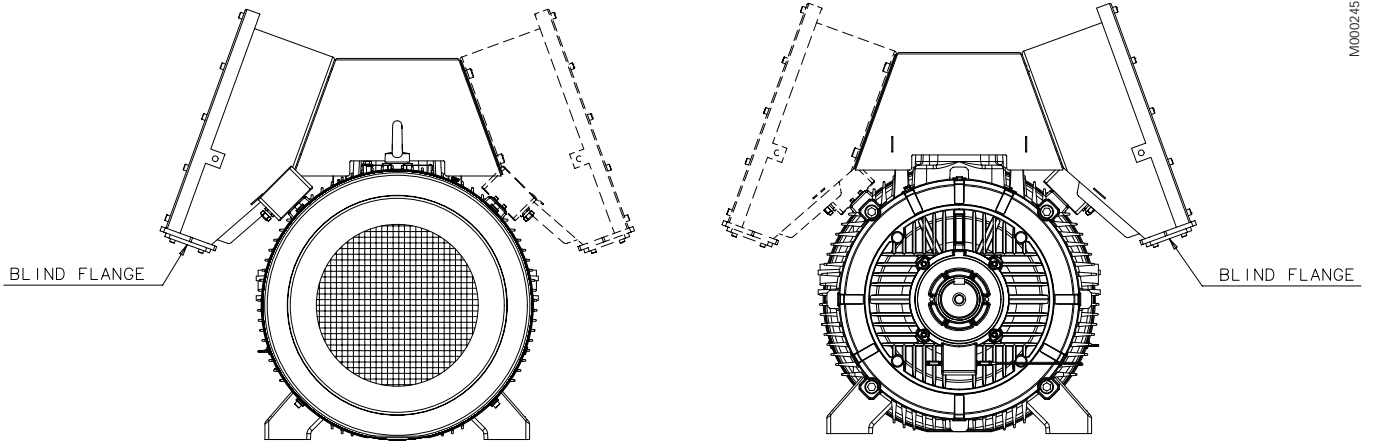

Delivery without main terminal box (optional)

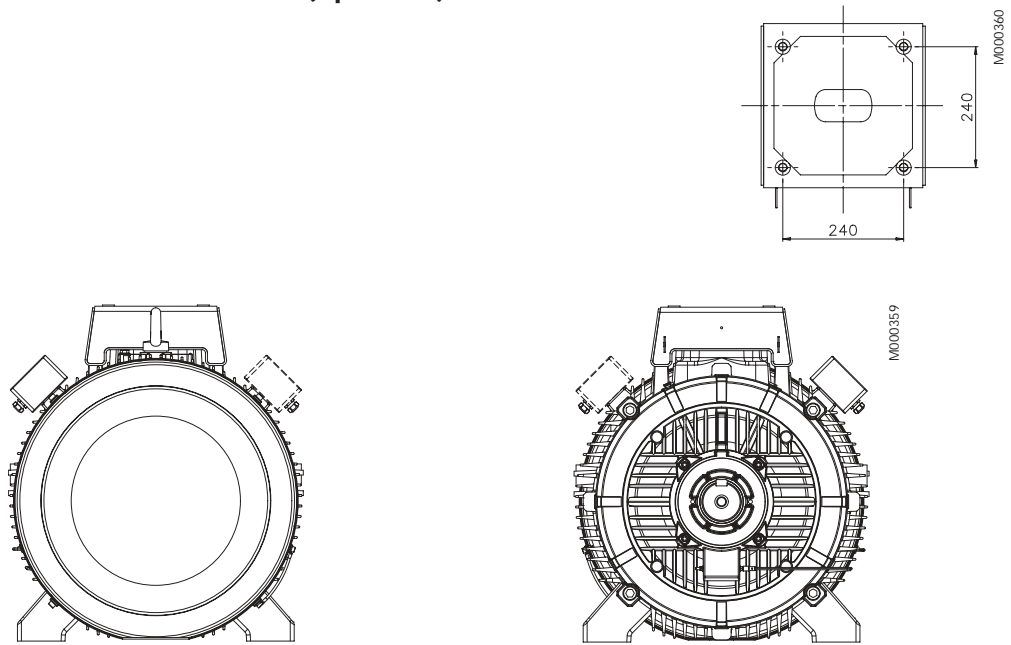

Dimensions for terminal box inlet, blind flange

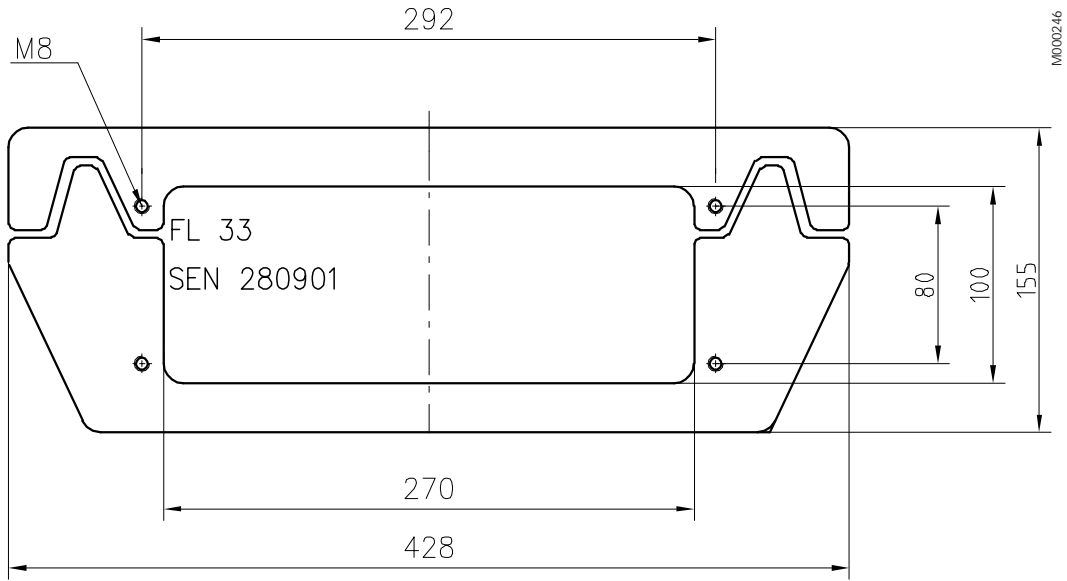

Blind flange up to 6.6 kV.

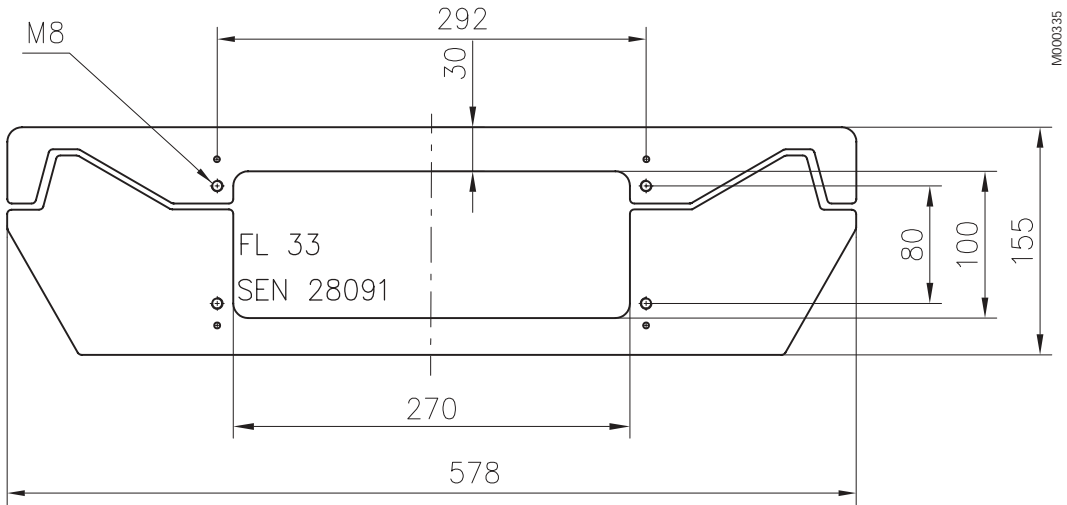

Blind flange up to 11 kV.

Auxiliary boxes

Auxiliary box is used for control equipment and heating elements.

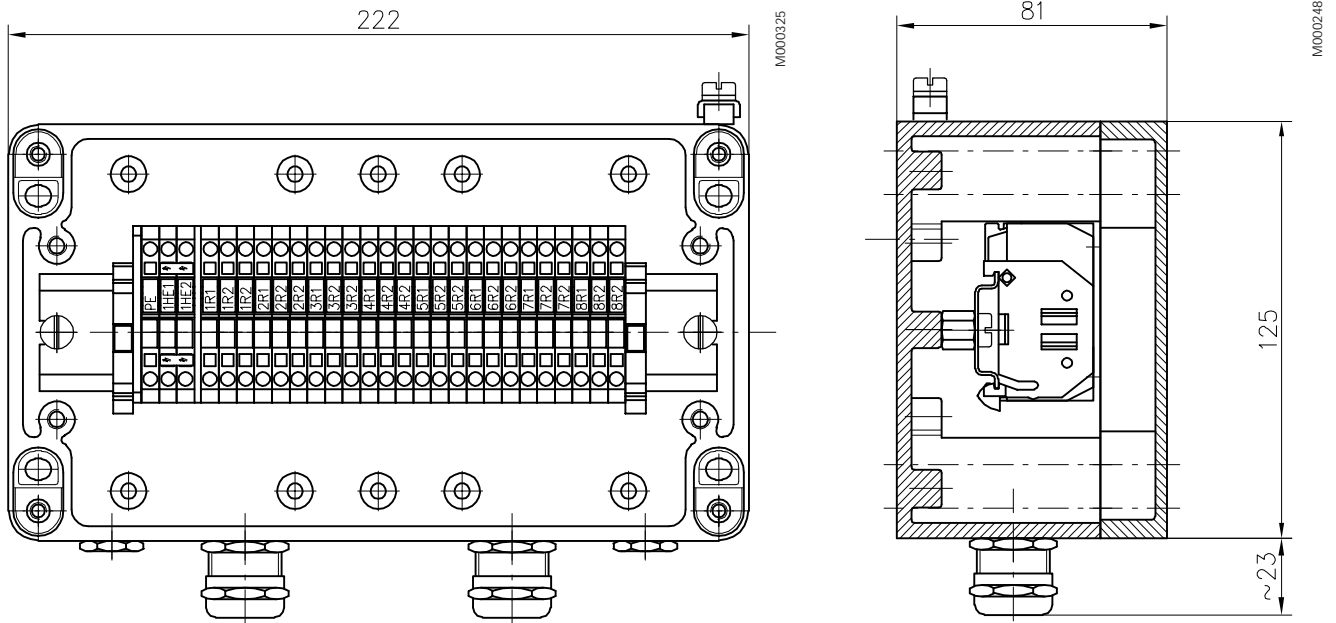

- one box as default
- stator Pt-100
- bearing Pt-100 (optional, variant code 107)
- heating element (optional, variant code 450/451)
- separate auxiliary box for heating element (optional, variant code 447)

Specification:

Material designation	Al-Si10Mg (pressure die cast)
Material standard	EN 573-3
Surface treatment	RAL 7001 (grey)

Other features:

- equipped with assembly rail ARH 22 (DIN-35, 35x203 mm)
- main dimensions 125x222x81
- degree of protection IP 66 (IEC 529)
- gasket material polyurethane
- temperature resistance -50 - +140 °C (material), +80 °C (continuous use)
- max. terminal blocks:

34 pcs	2.5 mm ²
28 pcs	4.0 mm ²
- weight 1.6 kg

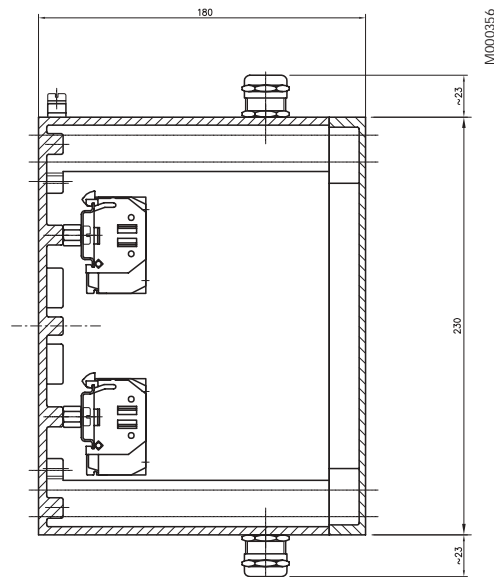
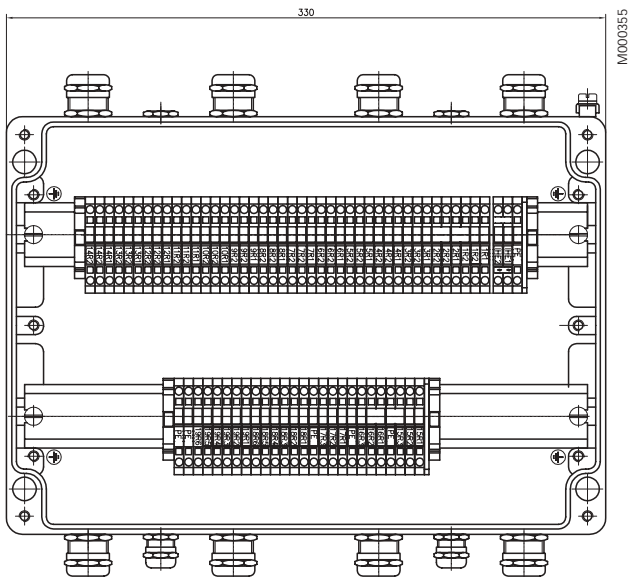

- one box as default
 - stator Pt-100 (6 pcs)
 - bearing Pt-100 (optional, variant code 107)
 - heating element (optional, variant code 450/451)
 - dial type thermometers for bearings (optional, variant code 651/652)*
 - Pt-100 (12 pcs) inside stator slots (optional, variant code 653)*
 - Provision for vibration sensors (optional, variant code 654)*

* The bigger auxiliary box is needed if any of these variant codes is selected.

Other features:

- equipped with assembly rail ARH 22 (DIN-35)
- main dimensions 125x222x81, 222x330x180
- degree of protection IP66 (IEC 529)
- gasket material polyurethane
- temperature resistance -50 - +140°C (material), +80 °C (continuous use)
- weight 1.6 – 5.6 kg

Specification:

Material designation	Al-Si10Mg (pressure die cast)
Material standard	EN 573-3
Surface treatment	RAL 7001 (grey)

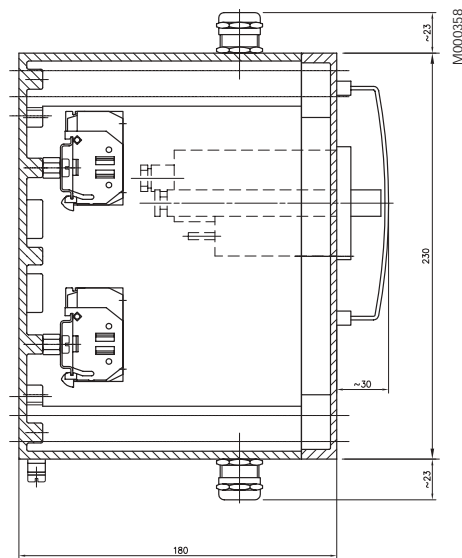
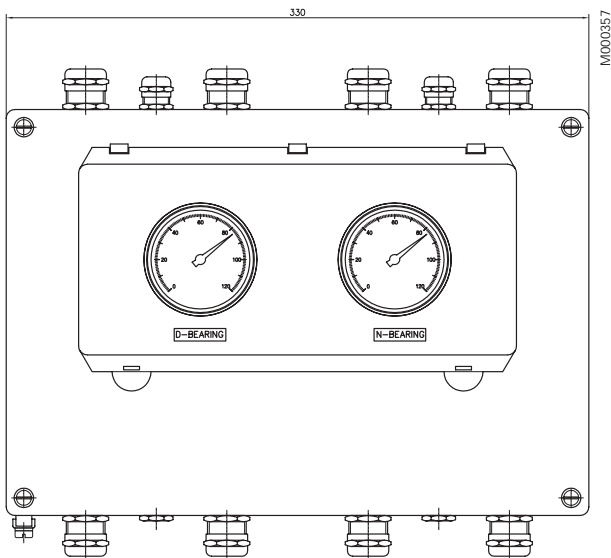

Option with bearing dial type thermometers

- Measuring range 0...120 °C
- Degree of protection : IP65 (IEC529)
- Temperature durability of display -40...+60 °C

- Temperature durability of capillary tube -40...+100 °C
- With or without contacts (optional, variant codes 652/651)

6

Bearings

The motors are normally fitted with single-row deep groove ball bearings as listed in the table below.

Basic version with deep groove ball bearings

Motor size	Number of poles	Deep groove ball bearings	
		D-end	N-end
315	2	6316M/C3	6316M/C3
	4-6	6319/C3	6316/C3
355	2	6316M/C3	6316M/C3
	4-6	6322/C3	6316/C3
400	2	6317M/C3	6317M/C3
	4-8	6324/C3	6319/C3
450	2	6317M/C3	6317M/C3
	4-8	6326M/C3	6322/C3

If the bearing at the D-end is replaced with a roller bearing (NU-), higher radial forces can be handled. Roller bearings are suitable for belt drive applications.

Version with roller bearings, variant code 037

Motor size	Number of poles	Roller bearings, variant code 037
		D-end
315	4-6	NU 319/C3
355	4-6	NU 322/C3
400	4-8	NU 324/C3
450	4-8	NU 326/C3

Axially-locked bearings

All motors are equipped as standard with an axially-locked bearing at the D-end.

The bearing's outer ring is tightly locked between bearing's covers and the housing fit.

The N-end bearing is axially free and can take the thermal expansion. Note! NU-bearing is axially locked at N-end.

Transport locking

Motors with roller bearings are fitted with a transport lock to prevent damage to the bearings during transport. All high voltage motors are fitted with a warning sign when the transport lock is fitted to prevent operational damage and alert operators.

Locking may be fitted in any other situations where the transport conditions are considered as potentially damaging.

Bearing seals

All high voltage motors are equipped with labyrinth sealed bearings.

Axially free (N-end)

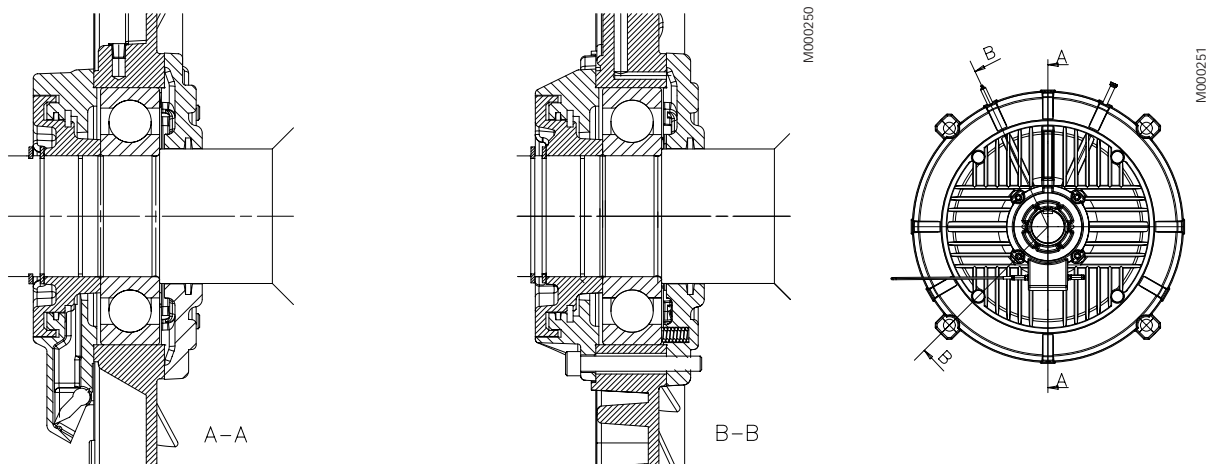

Axially locked (D-end)

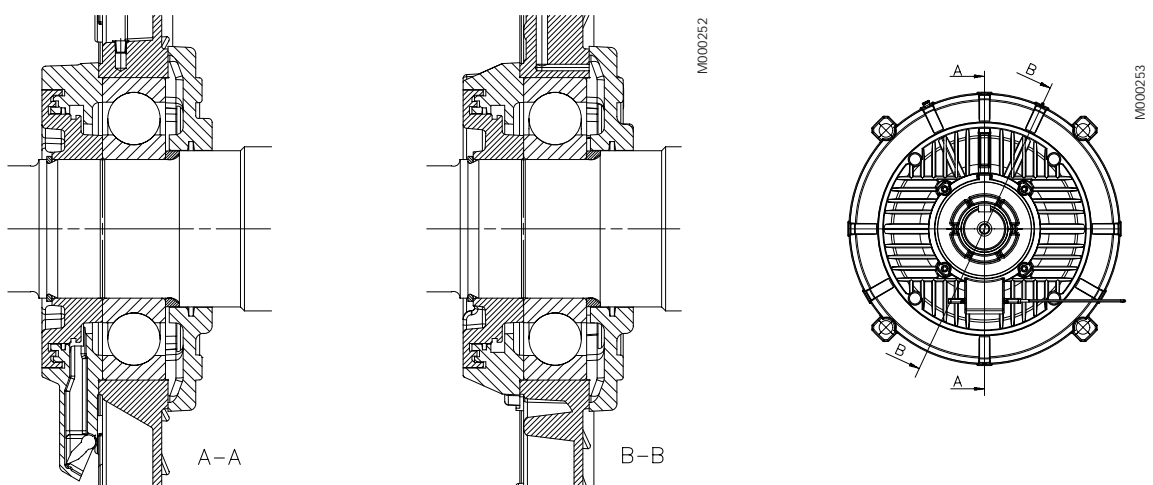

Lubrication

On delivery, the motors are pre-lubricated with high quality grease. The grease grade is stamped on the lubrication plate fastened to the motor frame. See page 152 for an example of a lubrication plate.

More information about lubrication and greases can be found in ABB's High Voltage Process Performance Manual delivered with the motor.

Lubrication intervals

The lubrication interval is defined by following the L1-principle. This means that 99% of ABB's motors will achieve the normal service intervals. Values for the lubrication intervals can also be calculated according to the L10-principle, which are normally doubled compared to L1-values. Values are available from ABB on request.

Frame size	Ambient °C	3000 r/min	1500 r/min	<1000 r/min
Ball bearings, horizontal motor: lubrication intervals in duty hours				
315	25	5900	8800	8800
315	40 ¹⁾	3000	6600	8800
355	25	4400	8800	8800
355	40 ¹⁾	2200	5100	8800
400	25	3000	6600	8800
400	40 ¹⁾	1500	3600	8000
450	25	3000	6600	8800
450	40 ¹⁾	1500	3600	8000

¹⁾ For generation code B motors, same lubrication intervals are valid for 50°C ambient.

Frame size	Ambient °C	3000 r/min	1500 r/min	<1000 r/min
Roller bearings: lubrication intervals in duty hours				
315	25	-	4400	8800
315	40 ¹⁾	-	2200	5100
355	25	-	4400	4400
355	40 ¹⁾	-	2200	2200
400	25	-	3000	4400
400	40 ¹⁾	-	1500	2200
450	25	-	3000	4400
450	40 ¹⁾	-	1500	2200

¹⁾ For generation code B motors, same lubrication intervals are valid for 50°C ambient.

Motors with relubrication nipples

Motors are lubricated while running and the bearing system on all high voltage motors has been built so that a valve disc can be used for lubrication.

The grease outlet opening has closing valves at both ends that should be opened before greasing and closed 1-2 hours after regreasing. Closing the valves ensures that the construction is tight and dust or dirt cannot get inside the bearing.

The table below gives lubrication intervals for different speeds (according to the L1-principle). The values are valid for motors using the synthetic base oil mentioned in ABB's High Voltage Process Performance Motors Manual.

For more information, see ABB's High Voltage Process Performance Motors Manual.

Frame size	Ambient °C	3000 r/min	1500 r/min	<1000 r/min
Ball bearings, vertical motor: lubrication intervals in duty hours				
315	25	-	6600	8800
315	40 ¹⁾	-	3600	4400
355	25	-	4400	8800
355	40 ¹⁾	-	2200	4400
400	25	-	3000	6600
400	40 ¹⁾	-	1500	3600
450	25	-	3000	6600
450	40 ¹⁾	-	1500	3600

¹⁾ For generation code B motors, same lubrication intervals are valid for 50°C ambient.

Pulley diameter

When the desired bearing life has been determined, the minimum permissible pulley diameter can be calculated using F_R , as follows:

$$D = \frac{1.9 \cdot 10^7 \cdot K \cdot P}{n \cdot F_R}$$

where:

- D = diameter of pulley, mm
- P = power requirement, kW
- n = motor speed, r/min
- K = belt tension factor, dependent on belt type and type of duty. A common value for V-belts is 2.5.
- F_R = permissible radial force

Permissible loadings on shaft

The tables give the maximum permissible radial force in Newtons, assuming zero axial force, based on normal conditions at 50 Hz and calculated bearing lives L_{10h} for 40,000 hours.

Motors are foot-mounted IM 1001 (B3) version with force directed sideways. In some cases the strength of the shaft affects the permissible forces.

Permissible loads of simultaneous radial and axial forces can be supplied on request.

If the radial force is applied between points X_0 and X_{max} , the permissible force F_R can be calculated from the following formula:

$$F_R = F_{x0} - \frac{X}{E} (F_{x0} - F_{xmax})$$

E = length of shaft extension in basic version

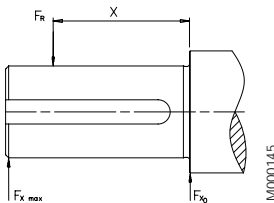

Permissible radial forces

Motor size	Poles	Length of shaft extension E (mm)	Ball bearings		Roller bearings	
			40,000 hours		40,000 hours	
			F_{X0} (N)	$F_{X_{max}}$ (N)	F_{X0} (N)	$F_{X_{max}}$ (N)
315LK	2	140	4850	4300	-	-
	4	170	7900	6850	25000	9500
	6	170	9050	7850	30000	9500
355LK	2	140	2350	2150	-	-
	4	210	9900	8600	25000	12000
	6	210	11500	9950	40000	12000
400L / LK	2	170	550	500	-	-
	4	210	8130	7160	25000	15000
	6-8	210	10190	8900	45000	15000
450L	2	170	-	-	-	-
	4	210	8950	7950	25000	20800
	6-8	210	10430	9250	50000	20800

Permissible axial forces

The following tables give the permissible axial forces in Newton, assuming zero radial force. The values are based on normal conditions at 50 Hz with standard bearings and calculated bearing lives L_{10h} 40,000 hours.

Given axial forces $F_{AD'}$ assumes D-bearing locked by means of locking ring.

Mounting arrangement IM B3

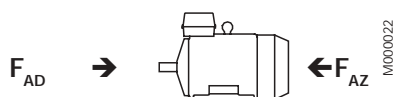

Motor size	40,000 hours					
	2-pole		4-pole		6-8-pole	
	F_{AD}	F_{AZ}	F_{AD}	F_{AZ}	F_{AD}	F_{AZ}
	N	N	N	N	N	N
315LK	2050	4050	4150	6150	5050	7050
355LK	850	4650	4350	8150	5650	9450
400L / LK	200	5200	2990	8990	3970	9970
450L	-	-	3200	9200	4220	10220

Mounting arrangement IM V1

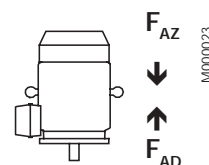

Motor size	40,000 hours					
	2-pole		4-pole		6-8-pole	
	F_{AD}	F_{AZ}	F_{AD}	F_{AZ}	F_{AD}	F_{AZ}
	N	N	N	N	N	N
315LK	-	-	7650	3750	9150	4350
355LK	-	-	10900	3850	12700	4600
400L / LK	-	-	11550	2780	15100	2480
450L	-	-	15420	800	19080	380

Vibration limits / Balancing

Motors are balanced according to ISO1940:1998 standard, balancing grade G2.5.

The following table lists the vibration values that the machines fulfil in compliance with IEC 60034-14.



Poles	Speed rpm	Design	Bearing housing vibration
2	1800 < n 3600	Standard	2.3 mm/s rms
≥4	1800	Standard	2.3 mm/s rms

Rating plate

Rating plate

ABB Oy, Electrical Machines Induction Machines, Helsinki, Finland						
3 ~ Motor M3BM 355 LKA 4 B3						
IEC 355 L/K 100						
S1				No. 4574949		
Temperature rise cl. B		Ins.cl. F		IP 55		
V	Hz	kW	r/min	A	cosφ	Duty
3000	50	250	1490	61	0.83	
Product code 3GBM352810-AQA						
Year of manufacture 2003		Nmax 1800 r/min				
6322/C3		6316/C3		1860 kg		
 IEC 60034-1						

Lubrication plate

		
Bearings	6324/C3 	6319/C3
Regreasing amount	60 g 	35 g
Regreasing intervals valid with following running speed and ambient temperatures:	1500 rpm	
At 25 °C	4400 h	
At 40 °C	2400 h	
Grease	KLUBERPLEX BEM 41-132	
See the Maintenance Manual		

Restamping output, voltage, ambient and altitude

M3BM motor catalogue ratings can be re-stamped as follows. Motor construction will not be changed but a new rating plate and data sheet can be created with variant code 002. In all the below cases or their combinations, please contact ABB for correct motor size and motor data. Bearing re-lubrication intervals as shown in this catalogue are valid also for re-stamped motors.

Output

Output can be re-stamped downwards from the catalogue data.

Voltage

Voltage can be re-stamped downwards up to 10% from the motor nominal voltage in the catalogue. Motor output has to be de-rated so that the motor absolute temperatures will not be higher compared to catalogue data.

Ambient temperature

Motor can be de-rated to higher ambient temperature. Maximum ambient temperature is 55 °C. The output has to be de-rated so that motor's absolute temperatures will not be higher than the catalogue data.

Altitude

Motor can be de-rated to higher altitudes than standard 1000 meters above sea level. There are different maximum altitude limits for different motors depending on voltage level. The motor output has to be de-rated so that the absolute temperatures of the motor will not be higher than the catalogue data.

Note: M3GM (Ex) motors for higher than 1000 meters above sea level altitude can be offered only case by case from the manufacturing unit.

Ordering information

When placing an order, please state the following minimum data in the order, as in example.

The product code of the motor is composed in accordance with the following example.

Motor type	M3BM 315LKA
Pole number	4
Mounting arrangement (IM code)	IM B3 (IM 1001)
Rated output	110 kW
Product code	3GBM312810-AQA
Variant codes if needed	

Motor size

A	B	C	D, E, F, G													
M3BM	315LKA	3GBM 312 810	- AQA 003 etc.													
			1	2	3	4	5	6	7	8	9	10	11	12	13	14

- A Motor type
- B Motor size
- C Product code
- D Mounting arrangement code
- E Voltage and frequency code
- F Generation code
- G Variant codes

Explanation of the product code:

Positions 1 to 4

3GBM = Totally enclosed fan cooled squirrel cage motor with cast iron frame, high voltage

Positions 5 and 6

IEC-frame

31 = 315

35 = 355

40 = 400

45 = 450

Position 7

Speed (Pole pairs)

1 = 2 poles

2 = 4 poles

3 = 6 poles

4 = 8 poles

Position 8 to 10

Serial number

Position 11

- (dash)

Position 12

Mounting arrangement

A = Horizontal

B = Vertical

H = Foot- and flange-mounted,
terminal box top-mounted

Position 13

Voltage and frequency code

See table below

Position 14

Generation code

A = Motor designed for 40°C ambient

B = Motor designed for 50°C ambient

The product code must be, if needed, followed by variant codes.

Code letters for supplementing the product code - single speed motors

Code letter for voltage and frequency

Q	R	S	T	Y
50 Hz	50 Hz	50 Hz	50 Hz	50 Hz
3000 V	3300 V	6600 V	6000 V	10000 V

HV Process performance cast iron motors

Technical data for totally enclosed squirrel cage three phase motors

IP 55 – IC 411 – Insulation class F, temperature rise class B, ambient temperature 40°C

Output kW	Motor type	Product code	Speed r/min	Efficiency		Power factor		Current			
				Full load 100%	3/4 load 75%	Full load 100%	3/4 load 75%	I _N A	I _s A	I ₀ A	
3000 r/min = 2 poles				3000 V 50 Hz							
132	M3BM	315 LKA 3GBM	311810-•QA	2971	94.6	94.5	0.92	0.92	29	6.3	5
160	M3BM	315 LKB 3GBM	311820-•QA	2971	94.9	94.8	0.92	0.92	35	6.5	6
200	³⁾ M3BM	355 LKA 3GBM	351811-•QA	2974	94.8	94.7	0.90	0.90	45	5.6	9
250	³⁾ M3BM	355 LKB 3GBM	351821-•QA	2975	95.4	95.3	0.90	0.90	56	6.1	11
315	³⁾ M3BM	355 LKC 3GBM	351831-•QA	2973	95.8	95.9	0.91	0.92	69	6.0	11
335	³⁾ M3BM	355 LKD 3GBM	351841-•QA	2972	95.9	96.0	0.91	0.92	74	6.0	11
355	³⁾ M3BM	355 LKE 3GBM	351850-•QA	2983	96.2	96.1	0.91	0.91	78	6.4	15
355	³⁾ M3BM	400 LA 3GBM	401510-•QA	2980	96.0	95.9	0.90	0.90	79	6.3	16
400	³⁾ M3BM	400 LB 3GBM	401520-•QA	2978	96.2	96.2	0.91	0.91	88	6.2	15
450	³⁾ M3BM	400 LC 3GBM	401530-•QA	2978	96.4	96.4	0.91	0.92	98	6.4	16
500	³⁾ M3BM	400 LKA 3GBM	401810-•QA	2983	96.7	96.6	0.91	0.91	109	6.2	19
560	³⁾ M3BM	400 LKB 3GBM	401820-•QA	2983	96.8	96.8	0.91	0.92	122	6.1	19
630	³⁾ M3BM	450 LA 3GBM	451510-•QA	2986	96.9	96.8	0.91	0.91	138	6.5	26
710	³⁾ M3BM	450 LB 3GBM	451520-•QA	2986	97.1	97.0	0.91	0.91	154	6.5	27
3000 r/min = 2 poles				3300 V 50 Hz							
160	M3BM	315 LKA 3GBM	311811-•RA	2976	95.0	94.9	0.91	0.91	32	6.4	6
200	³⁾ M3BM	355 LKA 3GBM	351811-•RA	2978	94.9	94.6	0.90	0.89	41	6.3	9
250	³⁾ M3BM	355 LKB 3GBM	351821-•RA	2975	95.4	95.3	0.90	0.90	51	6.1	10
315	³⁾ M3BM	355 LKC 3GBM	351831-•RA	2975	95.9	95.9	0.91	0.92	63	6.4	11
335	³⁾ M3BM	355 LKD 3GBM	351841-•RA	2975	96.0	96.1	0.91	0.92	67	6.5	11
355	³⁾ M3BM	400 LA 3GBM	401510-•RA	2979	96.1	95.9	0.90	0.90	71	6.3	14
400	³⁾ M3BM	400 LB 3GBM	401520-•RA	2978	96.2	96.2	0.91	0.91	80	6.2	14
450	³⁾ M3BM	400 LC 3GBM	401530-•RA	2977	96.4	96.4	0.91	0.92	89	6.1	14
500	³⁾ M3BM	400 LKA 3GBM	401810-•RA	2983	96.7	96.7	0.91	0.92	99	6.0	16
560	³⁾ M3BM	400 LKB 3GBM	401820-•RA	2983	96.8	96.8	0.91	0.92	111	6.1	17
630	³⁾ M3BM	450 LA 3GBM	451510-•RA	2986	96.9	96.8	0.91	0.91	125	6.5	24
700	³⁾ M3BM	450 LB 3GBM	451520-•RA	2986	97.1	97.0	0.91	0.91	138	6.5	24
3000 r/min = 2 poles				6000 V 50 Hz							
250	³⁾ M3BM	355 LKA 3GBM	351811-•TA	2975	95.2	95.2	0.91	0.92	28	6.1	5
280	³⁾ M3BM	355 LKB 3GBM	351821-•TA	2982	95.6	95.5	0.91	0.90	31	6.2	6
300	³⁾ M3BM	355 LKC 3GBM	351830-•TA	2982	95.8	95.7	0.91	0.91	33	6.3	6
315	³⁾ M3BM	400 LA 3GBM	401510-•TA	2981	95.5	95.4	0.89	0.88	35	6.4	8
355	³⁾ M3BM	400 LB 3GBM	401520-•TA	2979	95.9	95.8	0.91	0.91	39	6.3	7
400	³⁾ M3BM	400 LC 3GBM	401530-•TA	2978	96.0	96.0	0.91	0.91	44	6.2	8
425	³⁾ M3BM	400 LD 3GBM	401540-•TA	2978	96.2	96.2	0.91	0.92	46	6.4	8
450	³⁾ M3BM	400 LKA 3GBM	401810-•TA	2983	96.3	96.3	0.91	0.91	49	6.0	9
500	³⁾ M3BM	400 LKB 3GBM	401820-•TA	2984	96.5	96.5	0.91	0.92	55	6.4	10
530	³⁾ M3BM	400 LKC 3GBM	401830-•TA	2984	96.7	96.7	0.92	0.92	58	6.5	10
560	³⁾ M3BM	450 LA 3GBM	451510-•TA	2986	96.6	96.5	0.90	0.90	62	6.3	13
630	³⁾ M3BM	450 LB 3GBM	451520-•TA	2986	96.8	96.7	0.91	0.91	69	6.4	12
670	³⁾ M3BM	450 LC 3GBM	451530-•TA	2986	97.0	96.9	0.92	0.92	73	6.5	13
3000 r/min = 2 poles				6600 V 50 Hz							
280	³⁾ M3BM	355 LKA 3GBM	351811-•SA	2982	95.6	95.5	0.91	0.91	28	6.1	5
315	³⁾ M3BM	400 LA 3GBM	401510-•SA	2980	95.6	95.4	0.90	0.89	32	6.4	7
355	³⁾ M3BM	400 LB 3GBM	401520-•SA	2980	95.8	95.7	0.91	0.91	36	6.3	7
400	³⁾ M3BM	400 LC 3GBM	401530-•SA	2979	96.1	96.1	0.91	0.91	40	6.5	7
425	³⁾ M3BM	400 LD 3GBM	401540-•SA	2978	96.2	96.2	0.91	0.92	42	6.5	7
450	³⁾ M3BM	400 LKA 3GBM	401810-•SA	2983	96.4	96.4	0.91	0.91	45	6.1	8
500	³⁾ M3BM	400 LKB 3GBM	401820-•SA	2984	96.5	96.5	0.91	0.91	50	6.5	9
530	³⁾ M3BM	400 LKC 3GBM	401830-•SA	2984	96.7	96.7	0.92	0.92	52	6.5	9
560	³⁾ M3BM	450 LA 3GBM	451510-•SA	2986	96.6	96.5	0.90	0.90	56	6.3	11
630	³⁾ M3BM	450 LB 3GBM	451520-•SA	2987	96.8	96.7	0.91	0.91	63	6.4	12
670	³⁾ M3BM	450 LC 3GBM	451530-•SA	2986	96.9	96.9	0.91	0.92	66	6.4	11

¹⁾ 315LK, 355LK, 400L, 400LK: The given values of load inertia assume two starts from cold and one start from warm conditions in succession against quadratic load torque with 90% of the rated torque at the rated speed and at 80% of the rated voltage.

450L: The given values of load inertia assume two starts from cold and one start from warm conditions in succession against quadratic load torque with 85% of the rated torque at the rated speed and at 80% of the rated voltage. To check validity against other starting requirements, contact ABB.

²⁾ 315LK, 355LK, 400L, 400LK: Starting time with given values of the load inertia from cold condition in succession against quadratic load torque with 90% of the rated torque at the rated speed and at rated voltage.

450L: Starting time with given values of the load inertia from cold condition in succession against quadratic load torque with 85% of the rated torque at the rated speed and at rated voltage.

³⁾ Unidirectional fan construction as standard. Direction of rotation must be stated when ordering, see variant codes 044 and 045.

⁴⁾ The sound pressure levels are presented at no-load. The magnetic noise level of 2- and 4-pole motors is typically low compared to the fan noise, resulting no increase in the noise level on-load. The variation and measuring tolerance of the figures is +3 dB(A).

The bullet in the product code indicates choice of mounting arrangement (see ordering information page).

HV Process performance cast iron motors

Technical data for totally enclosed squirrel cage three phase motors

IP 55 – IC 411 – Insulation class F, temperature rise class B, ambient temperature 40°C

Output kW	Motor type	Torque			Power factor cos φ _k	Load inertia ¹⁾ kgm ²	Starting time cold ²⁾ s	Maximum stalling time hot s	Rotor inertia kgm ²	Rotor weight kg	Motor weight kg	Sound pressure level LP ⁴⁾ dB(A)
		T _N	T _S	T _{max}								
		Nm	T _N	T _N								
3000 r/min = 2 poles		3000 V 50 Hz										
132	M3BM 315 LKA	424	1.2	2.7	0.17	10	7	16	2.0	230	1230	78
160	M3BM 315 LKB	514	1.3	2.7	0.17	12	7	16	2.1	240	1270	78
200 ³⁾	M3BM 355 LKA	642	0.8	2.5	0.13	15	10	22	2.9	280	1680	78
250 ³⁾	M3BM 355 LKB	802	0.9	2.7	0.13	18	8	16	3.2	300	1780	78
315 ³⁾	M3BM 355 LKC	1012	1.0	2.5	0.13	22	8	16	4.5	390	2160	78
335 ³⁾	M3BM 355 LKD	1076	1.0	2.5	0.13	23	8	15	4.8	410	2240	78
355 ³⁾	M3BM 355 LKE	1137	0.9	2.7	0.12	24	8	16	4.7	390	2220	78
355 ³⁾	M3BM 400 LA	1138	1.0	2.6	0.13	24	9	20	6.9	460	2420	79
400 ³⁾	M3BM 400 LB	1283	1.0	2.5	0.13	27	9	20	8.0	520	2670	79
450 ³⁾	M3BM 400 LC	1443	1.1	2.6	0.14	30	8	20	9.2	580	2900	79
500 ³⁾	M3BM 400 LKA	1601	0.8	2.6	0.11	32	9	16	8.8	560	2980	79
560 ³⁾	M3BM 400 LKB	1793	0.9	2.6	0.11	36	9	16	9.9	620	3220	79
630 ³⁾	M3BM 450 LA	2015	0.7	2.8	0.09	39	10	20	13.5	700	4040	80
710 ³⁾	M3BM 450 LB	2271	0.8	2.8	0.09	43	9	20	15.0	770	4350	80
3000 r/min = 2 poles		3300 V 50 Hz										
160	M3BM 315 LKA	513	0.9	2.9	0.14	12	8	16	1.9	210	1190	78
200 ³⁾	M3BM 355 LKA	641	0.9	2.8	0.13	15	9	20	2.9	280	1680	78
250 ³⁾	M3BM 355 LKB	802	0.9	2.7	0.13	18	8	16	3.2	300	1780	78
315 ³⁾	M3BM 355 LKC	1011	1.1	2.7	0.14	22	7	15	4.5	390	2140	78
335 ³⁾	M3BM 355 LKD	1075	1.1	2.7	0.13	23	7	14	4.8	410	2250	78
355 ³⁾	M3BM 400 LA	1138	0.9	2.6	0.13	24	9	20	6.9	460	2440	79
400 ³⁾	M3BM 400 LB	1283	1.0	2.5	0.13	27	9	20	8.0	520	2660	79
450 ³⁾	M3BM 400 LC	1444	1.1	2.4	0.13	30	8	20	9.2	570	2910	79
500 ³⁾	M3BM 400 LKA	1601	0.8	2.5	0.11	32	10	16	9.4	590	3100	79
560 ³⁾	M3BM 400 LKB	1793	0.9	2.6	0.11	36	9	16	9.9	620	3220	79
630 ³⁾	M3BM 450 LA	2015	0.7	2.8	0.09	39	10	20	13.5	700	4040	80
700 ³⁾	M3BM 450 LB	2239	0.8	2.7	0.09	43	9	20	15.0	770	4340	80
3000 r/min = 2 poles		6000 V 50 Hz										
250 ³⁾	M3BM 355 LKA	803	1.0	2.6	0.15	18	8	16	4.2	370	2010	78
280 ³⁾	M3BM 355 LKB	897	0.9	2.6	0.13	20	9	18	4.1	350	2000	78
300 ³⁾	M3BM 355 LKC	961	0.9	2.6	0.13	21	9	18	4.4	370	2090	78
315 ³⁾	M3BM 400 LA	1009	1.0	2.7	0.14	22	9	20	6.4	430	2260	79
355 ³⁾	M3BM 400 LB	1138	1.0	2.6	0.14	24	9	20	7.5	490	2500	79
400 ³⁾	M3BM 400 LC	1283	1.0	2.5	0.14	27	9	20	8.0	520	2620	79
425 ³⁾	M3BM 400 LD	1363	1.1	2.5	0.14	28	8	20	8.9	560	2800	79
450 ³⁾	M3BM 400 LKA	1441	0.8	2.6	0.12	30	10	16	8.3	530	2820	79
500 ³⁾	M3BM 400 LKB	1600	0.8	2.7	0.12	32	9	16	9.4	590	3050	79
530 ³⁾	M3BM 400 LKC	1696	0.9	2.7	0.12	34	9	16	9.9	620	3170	79
560 ³⁾	M3BM 450 LA	1791	0.7	2.8	0.09	36	11	20	12.3	650	3760	80
630 ³⁾	M3BM 450 LB	2015	0.7	2.7	0.10	39	10	20	15.0	770	4250	80
670 ³⁾	M3BM 450 LC	2142	0.8	2.7	0.10	41	10	20	15.8	800	4440	80
3000 r/min = 2 poles		6600 V 50 Hz										
280 ³⁾	M3BM 355 LKA	897	0.9	2.6	0.14	20	10	16	4.4	370	2080	78
315 ³⁾	M3BM 400 LA	1009	1.0	2.7	0.14	22	9	20	6.4	430	2260	79
355 ³⁾	M3BM 400 LB	1138	1.0	2.6	0.14	24	9	20	7.5	490	2490	79
400 ³⁾	M3BM 400 LC	1282	1.1	2.6	0.14	27	8	20	8.0	520	2620	79
425 ³⁾	M3BM 400 LD	1363	1.2	2.6	0.15	28	8	18	8.9	560	2800	79
450 ³⁾	M3BM 400 LKA	1441	0.8	2.6	0.12	30	10	16	8.6	550	2880	79
500 ³⁾	M3BM 400 LKB	1600	0.9	2.7	0.12	32	9	16	9.4	590	3050	79
530 ³⁾	M3BM 400 LKC	1696	0.9	2.7	0.12	34	9	16	9.9	620	3170	79
560 ³⁾	M3BM 450 LA	1791	0.7	2.7	0.09	36	11	20	12.7	670	3830	80
630 ³⁾	M3BM 450 LB	2014	0.7	2.7	0.09	39	11	20	14.6	750	4200	80
670 ³⁾	M3BM 450 LC	2143	0.8	2.7	0.09	41	10	20	15.8	800	4440	80

HV Process performance cast iron motors

Technical data for totally enclosed squirrel cage three phase motors

IP 55 – IC 411 – Insulation class F, temperature rise class B, ambient temperature 40°C

Output kW	Motor type			Product code	Speed r/min	Efficiency		Power factor		Current		
						Full load 100%	3/4 load 75%	Full load 100%	3/4 load 75%	I _N A	I _S A	I ₀ A
1500 r/min = 4 poles					3000 V 50 Hz							
110	M3BM	315 LKA	3GBM	312810-•QA	1488	94.7	94.4	0.84	0.80	27	6.3	10
132	M3BM	315 LKB	3GBM	312820-•QA	1484	94.7	94.7	0.85	0.83	32	5.3	10
160	M3BM	315 LKC	3GBM	312830-•QA	1485	95.0	94.9	0.87	0.85	37	6.3	11
200	M3BM	315 LKD	3GBM	312841-•QA	1485	95.2	95.3	0.87	0.85	46	6.1	14
250	M3BM	355 LKA	3GBM	352810-•QA	1490	95.7	95.5	0.84	0.80	60	6.2	22
315	M3BM	355 LKB	3GBM	352820-•QA	1489	95.9	95.8	0.84	0.82	75	6.1	25
355	M3BM	355 LKC	3GBM	352830-•QA	1488	96.1	96.1	0.85	0.82	84	6.1	27
400	M3BM	355 LKD	3GBM	352841-•QA	1489	96.3	96.2	0.86	0.84	93	5.9	29
450	M3BM	400 LA	3GBM	402510-•QA	1490	96.7	96.7	0.86	0.84	105	6.5	32
500	M3BM	400 LB	3GBM	402520-•QA	1489	96.5	96.4	0.85	0.83	117	6.3	35
560	M3BM	400 LKA	3GBM	402810-•QA	1491	96.7	96.6	0.85	0.83	131	6.1	43
630	M3BM	400 LKB	3GBM	402820-•QA	1491	96.9	96.8	0.85	0.83	147	6.2	48
710	M3BM	450 LA	3GBM	452510-•QA	1493	97.0	96.8	0.88	0.86	160	6.5	44
750	M3BM	450 LB	3GBM	452520-•QA	1492	97.0	96.9	0.88	0.87	169	6.1	44
1500 r/min = 4 poles					3300 V 50 Hz							
132	M3BM	315 LKA	3GBM	312810-•RA	1488	94.9	94.7	0.82	0.77	30	6.3	13
160	M3BM	315 LKB	3GBM	312820-•RA	1484	95.1	95.1	0.84	0.82	35	5.5	12
200	M3BM	315 LKC	3GBM	312831-•RA	1485	95.2	95.2	0.87	0.85	42	6.2	13
250	M3BM	355 LKA	3GBM	352810-•RA	1489	95.6	95.5	0.84	0.81	55	6.1	19
315	M3BM	355 LKB	3GBM	352820-•RA	1490	95.8	95.7	0.83	0.80	69	6.5	26
355	M3BM	355 LKC	3GBM	352830-•RA	1489	96.1	96.0	0.84	0.81	77	6.4	27
400	M3BM	355 LKD	3GBM	352841-•RA	1490	96.3	96.2	0.86	0.83	85	6.1	28
450	M3BM	400 LA	3GBM	402510-•RA	1489	96.7	96.7	0.85	0.84	95	6.2	28
500	M3BM	400 LB	3GBM	402520-•RA	1490	96.5	96.4	0.85	0.83	107	6.5	34
560	M3BM	400 LKA	3GBM	402810-•RA	1491	96.7	96.6	0.85	0.83	119	6.1	39
630	M3BM	400 LKB	3GBM	402820-•RA	1491	96.8	96.8	0.85	0.83	133	6.1	43
630	M3BM	450 LA	3GBM	452510-•RA	1493	96.8	96.7	0.88	0.86	130	6.3	36
710	M3BM	450 LB	3GBM	452520-•RA	1492	96.9	96.8	0.88	0.86	146	6.3	39
1500 r/min = 4 poles					6000 V 50 Hz							
250	M3BM	355 LKA	3GBM	352810-•TA	1486	95.5	95.5	0.84	0.81	30	5.8	10
315	M3BM	355 LKB	3GBM	352821-•TA	1489	96.1	95.9	0.83	0.79	38	6.4	15
355	M3BM	400 LA	3GBM	402510-•TA	1489	96.2	96.2	0.86	0.84	42	6.2	13
400	M3BM	400 LB	3GBM	402520-•TA	1489	96.4	96.4	0.86	0.84	47	6.4	14
450	M3BM	400 LC	3GBM	402530-•TA	1489	96.2	96.2	0.86	0.85	52	6.3	15
500	M3BM	400 LKA	3GBM	402810-•TA	1491	96.5	96.4	0.85	0.83	58	6.0	19
560	M3BM	400 LKB	3GBM	402820-•TA	1491	96.6	96.6	0.86	0.84	65	5.9	20
600	M3BM	400 LKC	3GBM	402830-•TA	1492	96.7	96.6	0.85	0.82	70	6.5	24
630	M3BM	450 LA	3GBM	452510-•TA	1493	96.7	96.6	0.87	0.85	72	6.5	21
710	M3BM	450 LB	3GBM	452520-•TA	1493	96.9	96.8	0.88	0.86	80	6.4	22
1500 r/min = 4 poles					6600 V 50 Hz							
250	M3BM	355 LKA	3GBM	352810-•SA	1488	95.6	95.5	0.83	0.80	28	6.2	11
315	M3BM	355 LKB	3GBM	352820-•SA	1487	95.9	95.9	0.84	0.81	34	6.4	12
355	M3BM	400 LA	3GBM	402510-•SA	1489	96.2	96.2	0.86	0.84	38	6.2	11
400	M3BM	400 LB	3GBM	402520-•SA	1489	96.3	96.4	0.86	0.84	42	6.3	13
450	M3BM	400 LC	3GBM	402530-•SA	1489	96.2	96.2	0.86	0.84	48	6.5	14
500	M3BM	400 LKA	3GBM	402810-•SA	1491	96.5	96.4	0.85	0.83	53	6.1	18
560	M3BM	400 LKB	3GBM	402820-•SA	1491	96.6	96.6	0.86	0.84	59	5.9	18
600	M3BM	400 LKC	3GBM	402830-•SA	1491	96.7	96.6	0.85	0.83	64	6.3	21
630	M3BM	450 LA	3GBM	452510-•SA	1493	96.7	96.6	0.87	0.85	65	6.5	19
710	M3BM	450 LB	3GBM	452520-•SA	1492	96.9	96.8	0.88	0.86	73	6.3	20

¹⁾ The given values of load inertia assume three starts from cold and two starts from warm conditions in succession against quadratic load torque with 90% of the rated torque at the rated speed and at 80% of the rated voltage.

To check validity against other starting requirements, contact ABB.

²⁾ Starting time with given values of the load inertia from cold condition in succession against quadratic load torque with 90% of the rated torque at the rated speed and at rated voltage.

³⁾ The sound pressure levels are presented at no-load. The magnetic noise level of 2- and 4-pole motors is typically low compared to the fan noise, resulting no increase in the noise level on-load. The variation and measuring tolerance of the figures is +3 dB(A).

The bullet in the product code indicates choice of mounting arrangement (see ordering information page).

HV Process performance cast iron motors

Technical data for totally enclosed squirrel cage three phase motors

IP 55 – IC 411 – Insulation class F, temperature rise class B, ambient temperature 40°C

Output kW	Motor type		Torque			Power factor $\cos \varphi_k$	Load inertia ¹⁾ kgm ²	Starting time cold ²⁾ s	Maximum stalling time hot s	Rotor inertia kgm ²	Rotor weight kg	Motor weight kg	Sound pressure level LP ³⁾ dB(A)
			T _N	T _S	T _{max}								
			Nm	T _N	T _N								
1500 r/min = 4 poles			3000 V 50 Hz										
110	M3BM	315 LKA	706	1.6	2.6	0.21	41	7	20	1.9	220	1190	73
132	M3BM	315 LKB	849	1.4	2.2	0.21	49	9	20	1.9	220	1190	73
160	M3BM	315 LKC	1029	1.7	2.5	0.21	58	6	16	2.8	260	1190	73
200	M3BM	315 LKD	1286	1.0	2.7	0.15	71	8	15	2.9	270	1220	73
250	M3BM	355 LKA	1603	1.3	2.5	0.16	87	8	18	5.5	400	1860	74
315	M3BM	355 LKB	2021	1.3	2.4	0.16	107	8	16	6.3	450	1990	74
355	M3BM	355 LKC	2278	1.4	2.4	0.16	119	7	14	6.8	480	2090	74
400	M3BM	355 LKD	2565	1.0	2.5	0.13	132	9	16	8.1	540	2270	74
450	M3BM	400 LA	2885	1.5	2.4	0.16	147	7	12	12.1	660	2880	74
500	M3BM	400 LB	3206	1.5	2.3	0.16	161	7	12	12.1	660	2870	79
560	M3BM	400 LKA	3587	1.0	2.6	0.12	177	9	14	13.7	730	3210	79
630	M3BM	400 LKB	4035	1.0	2.6	0.12	196	8	12	14.9	790	3380	79
710	M3BM	450 LA	4542	0.9	2.6	0.10	217	10	20	25.6	1050	4580	83
750	M3BM	450 LB	4800	0.8	2.4	0.10	228	11	20	25.6	1050	4580	83
1500 r/min = 4 poles			3300 V 50 Hz										
132	M3BM	315 LKA	847	1.7	2.6	0.21	49	7	20	1.9	220	1190	73
160	M3BM	315 LKB	1029	1.5	2.2	0.21	58	8	20	2.1	240	1260	73
200	M3BM	315 LKC	1286	1.0	2.7	0.15	71	8	15	2.9	270	1210	73
250	M3BM	355 LKA	1603	1.3	2.4	0.16	87	8	20	5.5	400	1860	74
315	M3BM	355 LKB	2019	1.5	2.5	0.17	107	7	16	6.3	450	1970	74
355	M3BM	355 LKC	2277	1.5	2.5	0.17	119	7	14	6.8	480	2070	74
400	M3BM	355 LKD	2564	1.0	2.5	0.13	132	9	16	8.1	540	2250	74
450	M3BM	400 LA	2886	1.4	2.2	0.16	147	7	12	11.3	620	2760	74
500	M3BM	400 LB	3205	1.5	2.4	0.16	161	7	11	12.1	660	2850	79
560	M3BM	400 LKA	3587	1.0	2.6	0.12	177	9	14	13.7	730	3200	79
630	M3BM	400 LKB	4036	1.0	2.5	0.12	196	9	12	14.9	790	3380	79
630	M3BM	450 LA	4031	0.8	2.6	0.10	196	11	20	23.5	980	4350	83
710	M3BM	450 LB	4543	0.8	2.5	0.10	217	10	20	25.6	1050	4570	83
1500 r/min = 4 poles			6000 V 50 Hz										
250	M3BM	355 LKA	1606	1.3	2.3	0.17	87	8	20	4.1	380	2010	74
315	M3BM	355 LKB	2021	1.1	2.7	0.14	107	8	20	4.8	420	2200	74
355	M3BM	400 LA	2277	1.4	2.3	0.17	119	7	17	10.8	600	2590	74
400	M3BM	400 LB	2565	1.5	2.4	0.17	132	7	14	11.6	640	2720	74
450	M3BM	400 LC	2887	1.5	2.3	0.17	147	7	12	12.4	670	2840	79
500	M3BM	400 LKA	3203	1.0	2.5	0.13	161	9	16	12.9	700	3040	79
560	M3BM	400 LKB	3588	1.0	2.5	0.13	177	9	14	14.1	750	3220	79
600	M3BM	400 LKC	3841	1.1	2.7	0.12	188	8	12	14.9	790	3330	79
630	M3BM	450 LA	4030	0.8	2.6	0.10	196	10	20	22.8	960	4230	83
710	M3BM	450 LB	4543	0.8	2.6	0.10	217	10	20	25.6	1050	4530	83
1500 r/min = 4 poles			6600 V 50 Hz										
250	M3BM	355 LKA	1605	1.4	2.5	0.17	87	7	20	4.1	380	2010	74
315	M3BM	355 LKB	2023	1.4	2.5	0.17	107	7	20	5.0	440	2280	74
355	M3BM	400 LA	2277	1.4	2.3	0.17	119	7	17	10.8	600	2600	74
400	M3BM	400 LB	2566	1.5	2.3	0.17	132	7	14	11.6	640	2710	74
450	M3BM	400 LC	2886	1.6	2.4	0.17	147	6	12	12.4	670	2830	79
500	M3BM	400 LKA	3202	1.0	2.6	0.13	161	9	15	12.9	700	3040	79
560	M3BM	400 LKB	3588	1.0	2.5	0.13	177	9	14	14.1	750	3210	79
600	M3BM	400 LKC	3842	1.1	2.6	0.13	188	8	12	14.9	790	3330	79
630	M3BM	450 LA	4030	0.8	2.6	0.10	196	10	20	22.8	960	4230	83
710	M3BM	450 LB	4543	0.8	2.5	0.10	217	11	20	25.6	1050	4530	83

HV Process performance cast iron motors

Technical data for totally enclosed squirrel cage three phase motors

IP 55 – IC 411 – Insulation class F, temperature rise class B, ambient temperature 40°C

Output kW	Motor type	Product code	Speed r/min	Efficiency		Power factor		Current			
				Full load 100%	3/4 load 75%	Full load 100%	3/4 load 75%	I _N A	I _S A	I ₀ A	
1000 r/min = 6 poles				3000 V 50 Hz							
110	M3BM	315 LKA 3GBM	313810-•QA	987	94.4	94.6	0.80	0.77	28	5.3	11
132	M3BM	315 LKB 3GBM	313820-•QA	986	94.7	95.0	0.80	0.77	33	5.5	13
150	M3BM	315 LKC 3GBM	313831-•QA	991	95.3	95.1	0.76	0.69	40	6.2	21
160	M3BM	355 LKA 3GBM	353810-•QA	992	95.3	95.2	0.75	0.70	43	5.6	21
200	M3BM	355 LKB 3GBM	353820-•QA	990	95.7	95.7	0.79	0.75	51	5.4	21
250	M3BM	355 LKC 3GBM	353830-•QA	991	96.0	96.0	0.79	0.75	64	5.6	27
315	M3BM	400 L 3GBM	403500-•QA	991	96.1	96.2	0.82	0.79	77	6.0	28
355	M3BM	400 LA 3GBM	403510-•QA	991	96.3	96.4	0.82	0.80	86	5.9	30
400	M3BM	400 LB 3GBM	403520-•QA	991	96.4	96.5	0.82	0.80	97	6.2	34
450	M3BM	400 LKA 3GBM	403810-•QA	994	96.7	96.7	0.79	0.75	113	6.1	48
500	M3BM	400 LKB 3GBM	403820-•QA	994	96.8	96.8	0.81	0.77	123	5.9	48
530	M3BM	400 LKC 3GBM	403830-•QA	994	96.8	96.8	0.78	0.73	135	6.5	62
560	M3BM	450 LA 3GBM	453510-•QA	994	96.8	96.8	0.84	0.81	133	6.0	46
630	M3BM	450 LB 3GBM	453520-•QA	995	97.0	96.9	0.84	0.81	148	6.4	52
710	M3BM	450 LC 3GBM	453530-•QA	995	97.0	97.0	0.84	0.81	168	6.5	60
1000 r/min = 6 poles				3300 V 50 Hz							
112	M3BM	315 LKA 3GBM	313811-•RA	991	94.9	94.9	0.79	0.74	26	5.8	12
132	M3BM	315 LKB 3GBM	313820-•RA	987	94.8	94.9	0.80	0.76	31	5.6	13
150	M3BM	315 LKC 3GBM	313831-•RA	991	95.2	95.1	0.76	0.69	36	6.2	19
160	M3BM	355 LKA 3GBM	353810-•RA	992	95.3	95.2	0.75	0.69	39	5.7	20
200	M3BM	355 LKB 3GBM	353820-•RA	990	95.7	95.7	0.79	0.75	46	5.4	19
250	M3BM	355 LKC 3GBM	353830-•RA	990	95.9	96.0	0.80	0.76	57	5.4	23
315	M3BM	400 L 3GBM	403500-•RA	990	96.1	96.2	0.82	0.80	70	5.7	24
355	M3BM	400 LA 3GBM	403510-•RA	991	96.2	96.3	0.82	0.80	79	6.0	27
400	M3BM	400 LB 3GBM	403520-•RA	991	96.4	96.5	0.82	0.80	88	6.1	30
450	M3BM	400 LKA 3GBM	403810-•RA	994	96.7	96.7	0.80	0.76	102	6.0	42
500	M3BM	400 LKB 3GBM	403820-•RA	994	96.8	96.8	0.81	0.77	112	5.9	44
530	M3BM	400 LKC 3GBM	403830-•RA	994	96.8	96.8	0.79	0.74	122	6.5	55
560	M3BM	450 LA 3GBM	453510-•RA	994	96.8	96.8	0.84	0.82	120	6.1	41
630	M3BM	450 LB 3GBM	453520-•RA	995	97.0	96.9	0.84	0.81	135	6.5	48
710	M3BM	450 LC 3GBM	453530-•RA	995	97.0	97.0	0.84	0.81	152	6.5	54
1000 r/min = 6 poles				6000 V 50 Hz							
220	M3BM	355 LKA 3GBM	353810-•TA	992	95.5	95.6	0.80	0.76	28	6.3	12
250	M3BM	355 LKB 3GBM	353821-•TA	992	95.6	95.8	0.81	0.78	31	5.7	12
280	M3BM	400 L 3GBM	403500-•TA	991	96.0	96.0	0.80	0.76	35	5.6	14
315	M3BM	400 LA 3GBM	403510-•TA	992	96.2	96.2	0.80	0.76	39	5.8	16
355	M3BM	400 LB 3GBM	403520-•TA	991	96.3	96.3	0.80	0.77	44	5.6	17
400	M3BM	400 LKA 3GBM	403810-•TA	993	96.5	96.5	0.81	0.77	50	5.5	19
450	M3BM	400 LKB 3GBM	403820-•TA	992	96.6	96.6	0.81	0.78	55	5.4	20
475	M3BM	400 LKC 3GBM	403830-•TA	993	96.7	96.7	0.80	0.77	59	5.8	23
500	M3BM	450 LA 3GBM	453510-•TA	995	96.6	96.5	0.83	0.80	60	6.3	22
560	M3BM	450 LB 3GBM	453520-•TA	995	96.8	96.7	0.84	0.81	66	6.3	23
630	M3BM	450 LC 3GBM	453530-•TA	994	96.8	96.8	0.84	0.81	75	6.3	26
650	M3BM	450 LD 3GBM	453540-•TA	994	96.9	96.9	0.85	0.82	76	6.4	26
1000 r/min = 6 poles				6600 V 50 Hz							
250	M3BM	355 LKA 3GBM	353811-•SA	994	95.8	95.8	0.79	0.74	29	6.6	13
280	M3BM	400 L 3GBM	403500-•SA	991	96.0	96.0	0.79	0.75	32	5.6	13
315	M3BM	400 LA 3GBM	403510-•SA	992	96.2	96.1	0.79	0.75	36	6.1	16
355	M3BM	400 LB 3GBM	403520-•SA	991	96.3	96.3	0.80	0.76	40	5.9	16
400	M3BM	400 LKA 3GBM	403810-•SA	993	96.5	96.5	0.80	0.76	45	5.7	18
450	M3BM	400 LKB 3GBM	403820-•SA	992	96.6	96.6	0.81	0.78	50	5.4	19
475	M3BM	400 LKC 3GBM	403830-•SA	993	96.7	96.7	0.80	0.77	53	5.8	21
500	M3BM	450 LA 3GBM	453510-•SA	994	96.6	96.6	0.84	0.82	54	6.1	18
560	M3BM	450 LB 3GBM	453520-•SA	994	96.7	96.7	0.85	0.82	60	6.1	20
630	M3BM	450 LC 3GBM	453530-•SA	994	96.8	96.9	0.85	0.83	67	6.1	22

¹⁾ The given values of load inertia assume three starts from cold and two starts from warm conditions in succession against quadratic load torque with 90% of the rated torque at the rated speed and at 80% of the rated voltage. To check validity against other starting requirements, contact ABB.

²⁾ Starting time with given values of the load inertia from cold condition in succession against quadratic load torque with 90% of the rated torque at the rated speed and at rated voltage.

³⁾ The sound pressure levels are presented at no-load. Sound level values of 6...8-pole motors at no-load are typically 1...3 dB(A) higher than the corresponding values at no-load. The variation and measuring tolerance of the figures is +3 dB(A).

The bullet in the product code indicates choice of mounting arrangement (see ordering information page).

HV Process performance cast iron motors

Technical data for totally enclosed squirrel cage three phase motors

IP 55 – IC 411 – Insulation class F, temperature rise class B, ambient temperature 40°C

Output kW	Motor type	Torque			Power factor $\cos \phi_k$	Load inertia ¹⁾ kgm ²	Starting time cold ²⁾ s	Maximum stalling time hot s	Rotor inertia kgm ²	Rotor weight kg	Motor weight kg	Sound pressure level LP ³⁾ dB(A)
		T _N Nm	T _S T _N	T _{max} T _N								
1000 r/min = 6 poles		3000 V 50 Hz										
110	M3BM 315 LKA	1065	1.5	2.2	0.22	111	9	20	2.8	270	1170	65
132	M3BM 315 LKB	1278	1.6	2.3	0.22	131	8	20	3.2	290	1240	65
150	M3BM 315 LKC	1445	1.4	2.9	0.17	148	8	18	3.3	300	1270	65
160	M3BM 355 LKA	1541	1.5	2.4	0.18	157	8	20	4.6	350	1660	70
200	M3BM 355 LKB	1928	1.4	2.2	0.18	192	9	20	5.7	410	1850	70
250	M3BM 355 LKC	2410	1.5	2.3	0.18	236	8	20	6.9	480	2040	70
315	M3BM 400 L	3036	1.6	2.2	0.18	291	7	18	14.6	670	2500	75
355	M3BM 400 LA	3422	1.6	2.2	0.18	324	7	18	17.4	770	2740	75
400	M3BM 400 LB	3854	1.7	2.3	0.18	360	7	18	20.1	870	2970	75
450	M3BM 400 LKA	4323	1.2	2.5	0.14	400	9	20	19.4	860	3090	75
500	M3BM 400 LKB	4805	1.2	2.4	0.14	439	9	20	22.0	950	3320	75
530	M3BM 400 LKC	5090	1.4	2.7	0.13	463	8	20	22.7	980	3380	75
560	M3BM 450 LA	5379	1.1	2.5	0.14	486	10	20	29.2	1040	3990	78
630	M3BM 450 LB	6049	1.2	2.6	0.14	539	9	20	34.5	1190	4370	78
710	M3BM 450 LC	6817	1.3	2.6	0.14	598	8	20	36.7	1250	4520	78
1000 r/min = 6 poles		3300 V 50 Hz										
112	M3BM 315 LKA	1080	1.2	2.7	0.17	113	9	20	3.0	280	1200	65
132	M3BM 315 LKB	1277	1.6	2.4	0.22	131	8	20	3.2	290	1240	65
150	M3BM 315 LKC	1445	1.4	2.9	0.17	148	8	18	3.3	300	1270	65
160	M3BM 355 LKA	1540	1.5	2.5	0.18	157	8	20	4.6	350	1660	70
200	M3BM 355 LKB	1928	1.4	2.2	0.18	192	9	20	5.7	410	1850	70
250	M3BM 355 LKC	2412	1.4	2.2	0.18	236	9	20	6.9	480	2040	70
315	M3BM 400 L	3037	1.5	2.1	0.18	291	8	18	14.6	670	2500	75
355	M3BM 400 LA	3421	1.6	2.2	0.18	324	7	18	17.4	770	2730	75
400	M3BM 400 LB	3855	1.7	2.2	0.18	360	7	18	20.1	870	2970	75
450	M3BM 400 LKA	4324	1.2	2.4	0.13	400	9	20	20.1	880	3160	75
500	M3BM 400 LKB	4805	1.2	2.4	0.14	439	9	20	22.0	950	3320	75
530	M3BM 400 LKC	5090	1.3	2.7	0.14	463	8	20	22.7	980	3380	75
560	M3BM 450 LA	5379	1.1	2.5	0.14	486	9	20	30.3	1070	4070	78
630	M3BM 450 LB	6049	1.2	2.6	0.14	539	8	20	34.5	1190	4370	78
710	M3BM 450 LC	6817	1.3	2.6	0.14	598	8	20	36.7	1250	4520	78
1000 r/min = 6 poles		6000 V 50 Hz										
220	M3BM 355 LKA	2118	1.7	2.5	0.21	210	7	16	8.1	540	2160	70
250	M3BM 355 LKB	2406	1.1	2.4	0.16	203	9	14	8.0	530	2150	70
280	M3BM 400 L	2697	1.3	2.2	0.16	261	9	20	10.5	590	2530	75
315	M3BM 400 LA	3033	1.4	2.3	0.16	291	8	20	11.8	640	2700	75
355	M3BM 400 LB	3421	1.4	2.2	0.16	324	8	20	12.7	680	2820	75
400	M3BM 400 LKA	3848	0.9	2.4	0.11	360	11	20	13.5	720	3080	75
450	M3BM 400 LKB	4331	0.8	2.3	0.11	400	12	20	14.7	780	3260	75
475	M3BM 400 LKC	4569	0.9	2.5	0.11	420	10	20	15.5	810	3370	75
500	M3BM 450 LA	4801	1.2	2.7	0.14	439	9	20	28.2	1010	3880	78
560	M3BM 450 LB	5377	1.2	2.6	0.14	486	9	20	32.4	1130	4180	78
630	M3BM 450 LC	6050	1.4	2.5	0.16	539	7	20	37.2	1260	4480	78
650	M3BM 450 LD	6242	1.2	2.6	0.14	554	9	20	36.7	1250	4470	78
1000 r/min = 6 poles		6600 V 50 Hz										
250	M3BM 355 LKA	2403	1.3	2.8	0.16	236	8	14	8.3	540	2190	70
280	M3BM 400 L	2697	1.3	2.2	0.17	261	9	20	10.1	570	2470	75
315	M3BM 400 LA	3031	1.5	2.4	0.16	291	8	20	11.8	640	2700	75
355	M3BM 400 LB	3419	1.4	2.3	0.16	324	8	20	12.7	680	2820	75
400	M3BM 400 LKA	3847	0.9	2.4	0.11	360	11	20	13.5	720	3080	75
450	M3BM 400 LKB	4330	0.9	2.3	0.11	400	11	20	14.7	780	3250	75
475	M3BM 400 LKC	4569	0.9	2.5	0.11	420	10	20	15.5	810	3370	75
500	M3BM 450 LA	4802	1.1	2.5	0.14	439	10	20	29.2	1040	3950	78
560	M3BM 450 LB	5379	1.1	2.5	0.14	486	9	20	32.4	1130	4170	78
630	M3BM 450 LC	6051	1.2	2.5	0.14	539	9	20	36.7	1250	4470	78

HV Process performance cast iron motors

Technical data for totally enclosed squirrel cage three phase motors

IP 55 – IC 411 – Insulation class F, temperature rise class B, ambient temperature 40°C

Output kW	Motor type			Product code	Speed r/min	Efficiency		Power factor		Current		
						Full load	3/4 load	Full load	3/4 load	I _N	I _S	I ₀
						100%	75%	100%	75%	A	A	A
750 r/min = 8 poles						3000 V 50 Hz						
200	M3BM	400 LA	3GBM	404510-•QA	742	95.1	95.2	0.79	0.76	51	5.3	21
220	M3BM	400 LB	3GBM	404520-•QA	742	95.3	95.4	0.79	0.75	56	5.5	24
250	M3BM	400 LC	3GBM	404530-•QA	742	95.4	95.6	0.80	0.76	63	5.4	25
280	M3BM	400 LD	3GBM	404540-•QA	741	95.4	95.6	0.80	0.77	70	5.2	26
300	M3BM	400 LE	3GBM	404550-•QA	741	95.6	95.8	0.80	0.77	75	5.4	29
315	M3BM	400 LKA	3GBM	404810-•QA	744	95.8	95.8	0.77	0.73	82	5.2	37
355	M3BM	400 LKB	3GBM	404820-•QA	744	95.9	96.0	0.78	0.74	91	5.1	39
375	M3BM	400 LKC	3GBM	404830-•QA	744	96.0	96.0	0.76	0.71	98	5.6	47
400	M3BM	450 LA	3GBM	454510-•QA	746	96.3	96.1	0.78	0.74	102	5.9	46
450	M3BM	450 LB	3GBM	454520-•QA	746	96.4	96.2	0.78	0.73	115	6.0	53
500	M3BM	450 LC	3GBM	454530-•QA	746	96.5	96.4	0.78	0.74	127	6.1	58
530	M3BM	450 LD	3GBM	454540-•QA	746	96.5	96.3	0.78	0.73	135	6.1	62
750 r/min = 8 poles						3300 V 50 Hz						
200	M3BM	400 LA	3GBM	404510-•RA	742	95.0	95.2	0.79	0.76	46	5.2	19
220	M3BM	400 LB	3GBM	404520-•RA	742	95.2	95.4	0.80	0.76	51	5.3	20
250	M3BM	400 LC	3GBM	404530-•RA	741	95.3	95.6	0.80	0.78	57	5.0	21
280	M3BM	400 LD	3GBM	404540-•RA	741	95.5	95.7	0.80	0.77	64	5.5	25
300	M3BM	400 LE	3GBM	404550-•RA	741	95.5	95.7	0.80	0.77	69	5.5	27
315	M3BM	400 LKA	3GBM	404810-•RA	744	95.9	95.9	0.77	0.72	74	5.3	34
355	M3BM	400 LKB	3GBM	404820-•RA	744	95.9	95.9	0.78	0.74	83	5.1	36
375	M3BM	400 LKC	3GBM	404830-•RA	744	96.0	96.0	0.77	0.72	89	5.5	42
400	M3BM	450 LA	3GBM	454510-•RA	745	96.3	96.1	0.78	0.74	93	5.9	42
450	M3BM	450 LB	3GBM	454520-•RA	745	96.4	96.2	0.78	0.73	104	5.9	47
500	M3BM	450 LC	3GBM	454530-•RA	745	96.5	96.4	0.79	0.75	114	5.8	49
530	M3BM	450 LD	3GBM	454540-•RA	745	96.5	96.4	0.80	0.75	121	5.8	52
750 r/min = 8 poles						6000 V 50 Hz						
160	M3BM	400 LA	3GBM	404510-•TA	741	94.4	94.4	0.76	0.71	21	5.2	10
180	M3BM	400 LB	3GBM	404520-•TA	740	94.5	94.6	0.77	0.72	24	5.0	11
200	M3BM	400 LC	3GBM	404530-•TA	740	94.7	94.8	0.77	0.73	26	5.1	12
220	M3BM	400 LD	3GBM	404540-•TA	740	94.8	95.0	0.78	0.74	29	5.0	12
250	M3BM	400 LE	3GBM	404551-•TA	740	95.1	95.1	0.77	0.72	33	5.3	15
280	M3BM	400 LKA	3GBM	404810-•TA	743	95.6	95.6	0.77	0.72	37	5.3	17
315	M3BM	400 LKB	3GBM	404820-•TA	743	95.7	95.6	0.76	0.71	42	5.4	20
355	M3BM	450 LA	3GBM	454510-•TA	746	96.0	95.9	0.78	0.74	45	5.8	20
400	M3BM	450 LB	3GBM	454520-•TA	746	96.1	96.0	0.79	0.74	51	5.8	23
450	M3BM	450 LC	3GBM	454530-•TA	745	96.2	96.2	0.80	0.76	56	5.7	24
500	M3BM	450 LD	3GBM	454540-•TA	745	96.4	96.3	0.80	0.76	62	5.7	26
750 r/min = 8 poles						6600 V 50 Hz						
160	M3BM	400 LA	3GBM	404510-•SA	741	94.5	94.4	0.76	0.71	20	5.4	9
180	M3BM	400 LB	3GBM	404520-•SA	741	94.5	94.5	0.76	0.70	22	5.3	11
200	M3BM	400 LC	3GBM	404530-•SA	740	94.6	94.8	0.78	0.74	24	4.8	10
220	M3BM	400 LD	3GBM	404540-•SA	740	94.9	94.9	0.77	0.72	26	5.2	12
250	M3BM	400 LE	3GBM	404551-•SA	741	95.1	95.1	0.76	0.71	30	5.5	14
280	M3BM	400 LKA	3GBM	404810-•SA	743	95.6	95.5	0.76	0.71	34	5.4	16
315	M3BM	400 LKB	3GBM	404820-•SA	743	95.7	95.6	0.76	0.71	38	5.4	18
355	M3BM	450 LA	3GBM	454510-•SA	745	96.0	95.9	0.79	0.75	41	5.7	18
400	M3BM	450 LB	3GBM	454520-•SA	745	96.1	96.0	0.80	0.75	46	5.7	19
450	M3BM	450 LC	3GBM	454530-•SA	745	96.2	96.2	0.80	0.76	51	5.6	21
500	M3BM	450 LD	3GBM	454540-•SA	745	96.3	96.3	0.81	0.77	56	5.5	22

¹⁾ The given values of load inertia assume three starts from cold and two starts from warm conditions in succession against quadratic load torque with 90% of the rated torque at the rated speed and at 80% of the rated voltage. To check validity against other starting requirements, contact ABB.

²⁾ Starting time with given values of the load inertia from cold condition in succession against quadratic load torque with 90% of the rated torque at the rated speed and at rated voltage.

³⁾ The sound pressure levels are presented at no-load. Sound level values of 6...8-pole motors at no-load are typically 1...3 dB(A) higher than the corresponding values at no-load. The variation and measuring tolerance of the figures is +3 dB(A).

The bullet in the product code indicates choice of mounting arrangement (see ordering information page).

HV Process performance cast iron motors

Technical data for totally enclosed squirrel cage three phase motors

IP 55 – IC 411 – Insulation class F, temperature rise class B, ambient temperature 40°C

Output kW	Motor type	Torque			Power factor $\cos \varphi_k$	Load inertia ¹⁾ kgm ²	Starting time cold ²⁾ s	Maximum stalling time hot s	Rotor inertia kgm ²	Rotor weight kg	Motor weight kg	Sound pressure level LP ³⁾ dB(A)
		T _N Nm	T _s T _N	T _{max} T _N								
750 r/min = 8 poles		3000 V 50 Hz										
200	M3BM 400 LA	2575	1.0	2.4	0.15	388	10	22	13.6	630	2380	75
220	M3BM 400 LB	2831	1.1	2.5	0.14	423	10	22	15.0	680	2500	75
250	M3BM 400 LC	3219	1.1	2.4	0.14	476	10	22	17.7	780	2740	75
280	M3BM 400 LD	3610	1.1	2.3	0.14	528	10	22	19.1	830	2840	75
300	M3BM 400 LE	3866	1.1	2.4	0.14	562	9	22	20.5	870	2970	75
315	M3BM 400 LKA	4041	1.2	2.2	0.17	587	11	20	20.0	880	3090	75
355	M3BM 400 LKB	4557	1.2	2.1	0.17	655	11	20	22.0	950	3270	75
375	M3BM 400 LKC	4810	1.3	2.3	0.17	688	10	20	23.3	990	3390	75
400	M3BM 450 LA	5123	1.1	2.5	0.14	730	11	20	30.8	1080	4050	76
450	M3BM 450 LB	5763	1.2	2.5	0.14	811	10	20	33.0	1140	4210	76
500	M3BM 450 LC	6404	1.2	2.5	0.14	892	10	20	37.3	1260	4510	76
530	M3BM 450 LD	6787	1.2	2.6	0.14	940	10	20	39.5	1330	4640	76
750 r/min = 8 poles		3300 V 50 Hz										
200	M3BM 400 LA	2575	1.0	2.3	0.15	388	11	22	13.6	630	2380	75
220	M3BM 400 LB	2833	1.1	2.4	0.14	423	10	22	15.0	680	2500	75
250	M3BM 400 LC	3223	1.0	2.2	0.14	476	11	22	17.7	780	2730	75
280	M3BM 400 LD	3607	1.1	2.4	0.14	528	9	22	19.1	830	2850	75
300	M3BM 400 LE	3865	1.1	2.4	0.14	562	9	22	20.5	870	2950	75
315	M3BM 400 LKA	4041	1.2	2.2	0.17	587	11	20	20.0	880	3110	75
355	M3BM 400 LKB	4557	1.2	2.1	0.17	655	11	20	22.0	950	3260	75
375	M3BM 400 LKC	4811	1.3	2.3	0.17	688	10	20	23.3	990	3380	75
400	M3BM 450 LA	5124	1.1	2.5	0.14	730	11	20	30.8	1080	4050	76
450	M3BM 450 LB	5764	1.2	2.5	0.14	811	10	20	33.0	1140	4200	76
500	M3BM 450 LC	6406	1.1	2.4	0.14	892	10	20	37.3	1260	4510	76
530	M3BM 450 LD	6790	1.1	2.4	0.14	940	10	20	39.5	1330	4630	76
750 r/min = 8 poles		6000 V 50 Hz										
160	M3BM 400 LA	2062	1.1	2.5	0.16	315	10	22	10.2	560	2390	75
180	M3BM 400 LB	2322	1.0	2.4	0.16	352	11	22	10.7	580	2460	75
200	M3BM 400 LC	2580	1.1	2.4	0.15	388	10	22	12.1	640	2630	75
220	M3BM 400 LD	2840	1.0	2.3	0.15	423	10	22	13.0	680	2750	75
250	M3BM 400 LE	3225	1.2	2.5	0.15	476	9	22	14.4	740	2930	75
280	M3BM 400 LKA	3597	1.0	2.4	0.13	528	11	20	15.0	790	3230	75
315	M3BM 400 LKB	4047	1.0	2.5	0.13	587	10	20	15.9	830	3350	75
355	M3BM 450 LA	4547	1.1	2.4	0.15	655	11	20	28.6	1020	3850	76
400	M3BM 450 LB	5124	1.1	2.4	0.15	730	11	20	30.8	1080	4000	76
450	M3BM 450 LC	5766	1.1	2.3	0.15	811	11	20	35.2	1200	4300	76
500	M3BM 450 LD	6406	1.1	2.3	0.15	892	11	20	39.5	1330	4600	76
750 r/min = 8 poles		6600 V 50 Hz										
160	M3BM 400 LA	2061	1.1	2.6	0.16	315	10	22	10.7	580	2450	75
180	M3BM 400 LB	2319	1.1	2.6	0.16	352	10	22	10.7	580	2450	75
200	M3BM 400 LC	2583	1.0	2.3	0.15	388	11	22	12.1	640	2630	75
220	M3BM 400 LD	2838	1.1	2.5	0.15	423	10	22	13.0	680	2750	75
250	M3BM 400 LE	3223	1.2	2.6	0.15	476	9	22	14.4	740	2920	75
280	M3BM 400 LKA	3596	1.0	2.5	0.13	528	10	20	15.0	790	3230	75
315	M3BM 400 LKB	4047	1.0	2.5	0.13	587	10	20	15.9	830	3350	75
355	M3BM 450 LA	4548	1.1	2.4	0.15	655	11	20	29.7	1050	3920	76
400	M3BM 450 LB	5125	1.1	2.3	0.15	730	11	20	31.9	1110	4070	76
450	M3BM 450 LC	5767	1.1	2.3	0.15	811	12	20	35.2	1200	4300	76
500	M3BM 450 LD	6408	1.1	2.2	0.15	892	12	20	39.5	1330	4590	76

HV Process performance cast iron motors

Technical data for totally enclosed squirrel cage three phase motors

IP 55 – IC 411 – Insulation class F, temperature rise class B, ambient temperature 40°C

Output kW	Motor type	Product code	Speed r/min	Efficiency		Power factor		Current			
				Full load 100%	3/4 load 75%	Full load 100%	3/4 load 75%	I _N A	I _S A	I ₀ A	
3000 r/min = 2 poles				10000 V 50 Hz							
315 ³⁾	M3BM	450 LA 3GBM	451510-•YA	2988	95.3	94.9	0.89	0.87	22	6.4	6
355 ³⁾	M3BM	450 LB 3GBM	451520-•YA	2988	95.6	95.3	0.89	0.88	24	6.5	6
400 ³⁾	M3BM	450 LC 3GBM	451530-•YA	2988	95.7	95.4	0.89	0.87	27	6.1	7
450 ³⁾	M3BM	450 LD 3GBM	451540-•YA	2987	96.0	95.8	0.91	0.90	30	6.5	6
500 ³⁾	M3BM	450 LE 3GBM	451550-•YA	2987	96.2	96.1	0.91	0.91	33	6.3	6
1500 r/min = 4 poles				10000 V 50 Hz							
355	M3BM	450 LA 3GBM	452510-•YA	1492	95.6	95.3	0.83	0.80	26	5.7	10
400	M3BM	450 LB 3GBM	452520-•YA	1492	95.8	95.5	0.82	0.79	29	5.7	11
450	M3BM	450 LC 3GBM	452530-•YA	1492	96.0	95.7	0.83	0.79	33	6.0	13
500	M3BM	450 LD 3GBM	452540-•YA	1493	96.2	96.0	0.83	0.79	36	6.2	14
560	M3BM	450 LE 3GBM	452550-•YA	1493	96.4	96.2	0.83	0.79	41	6.5	16
1000 r/min = 6 poles				10000 V 50 Hz							
315	M3BM	450 LA 3GBM	453510-•YA	994	95.7	95.4	0.77	0.72	25	5.7	11
355	M3BM	450 LB 3GBM	453520-•YA	994	95.8	95.7	0.77	0.72	28	5.7	13
400	M3BM	450 LC 3GBM	453530-•YA	994	96.0	95.8	0.77	0.72	31	5.9	15
450	M3BM	450 LD 3GBM	453540-•YA	994	96.2	96.0	0.77	0.71	35	6.0	17

¹⁾ **2-pole motors:** The given values of load inertia assume two starts from cold and one start from warm conditions in succession against quadratic load torque with 75% of the rated torque at the rated speed and at 80% of the rated voltage.

4-pole motors: The given values of load inertia assume two starts from cold and one start from warm conditions in succession against quadratic load torque with 85% of the rated torque at the rated speed and at 80% of the rated voltage.

6-pole motors: The given values of load inertia assume two starts from cold and one start from warm conditions in succession against quadratic load torque with 90% of the rated torque at the rated speed and at 80% of the rated voltage.

To check validity against other starting requirements, contact ABB.

²⁾ **2-pole motors:** Starting time with given values of the load inertia from cold condition in succession against quadratic load torque with 80% of the rated torque at the rated speed and at rated voltage.

4-pole motors: Starting time with given values of the load inertia from cold condition in succession against quadratic load torque with 85% of the rated torque at the rated speed and at rated voltage.

6-pole motors: Starting time with given values of the load inertia from cold condition in succession against quadratic load torque with 90% of the rated torque at the rated speed and at rated voltage.

³⁾ Unidirectional fan construction as standard. Direction of rotation must be stated when ordering. see variant codes 044 and 045.

⁴⁾ The sound pressure levels are presented at no-load. The magnetic noise level of 2- and 4-pole motors is typically low compared to the fan noise, resulting no increase in the noise level on-load. The variation and measuring tolerance of the figures is +3 dB(A).

The bullet in the product code indicates choice of mounting arrangement (see ordering information page).

HV Process performance cast iron motors

Technical data for totally enclosed squirrel cage three phase motors

IP 55 – IC 411 – Insulation class F, temperature rise class B, ambient temperature 40°C

Output kW	Motor type		Torque			Power factor cos ϕ_k	Load inertia ¹⁾ kgm ²	Starting time cold ²⁾ s	Maximum stalling time hot s	Rotor inertia kgm ²	Rotor weight kg	Motor weight kg	Sound pressure level LP ⁴⁾ dB(A)
			T _N Nm	T _s T _N	T _{max} T _N								
3000 r/min = 2 poles			10000 V 50 Hz										
315 ³⁾	M3BM	450 LA	1007	0.6	3.0	0.10	22	16	22	10.5	570	3330	80
355 ³⁾	M3BM	450 LB	1134	0.6	3.0	0.10	24	15	22	11.2	600	3470	80
400 ³⁾	M3BM	450 LC	1278	0.5	2.8	0.10	27	16	22	11.2	600	3470	80
450 ³⁾	M3BM	450 LD	1438	0.7	2.7	0.11	30	13	20	13.1	690	3790	80
500 ³⁾	M3BM	450 LE	1599	0.7	2.7	0.10	32	12	20	13.9	720	3950	80
1500 r/min = 4 poles			10000 V 50 Hz										
355	M3BM	450 LA	2272	0.7	2.5	0.11	119	14	20	11.9	660	3610	83
400	M3BM	450 LB	2559	0.7	2.6	0.11	132	13	20	12.3	680	3690	83
450	M3BM	450 LC	2879	0.8	2.6	0.11	147	11	20	13.2	710	3800	83
500	M3BM	450 LD	3199	0.8	2.7	0.11	161	10	20	14.0	740	3960	83
560	M3BM	450 LE	3582	0.9	2.8	0.11	177	9	20	15.2	790	4180	83
1000 r/min = 6 poles			10000 V 50 Hz										
315	M3BM	450 LA	3027	0.8	2.6	0.12	291	11	20	14.0	740	3850	78
355	M3BM	450 LB	3412	0.9	2.6	0.12	324	10	20	14.8	780	4000	78
400	M3BM	450 LC	3844	0.9	2.7	0.12	360	10	20	15.7	810	4150	78
450	M3BM	450 LD	4323	0.9	2.7	0.11	400	9	20	17.0	860	4380	78

HV Process performance cast iron motors

Technical data for totally enclosed squirrel cage three phase motors

IP 55 - IC 411 - Insulation class F, temperature rise class B, ambient temperature 50°C

Output kW	Motor type	Product code	Speed r/min	Efficiency		Power factor		Current					
				Full load 100%	3/4 load 75%	Full load 100%	3/4 load 75%	I _N A	I _S A	I ₀ A			
3000 r/min = 2 poles			3300 V 50 Hz										
180	³⁾ M3BM	355 LKA 3GBM	351810-•RB	2979	94.8	94.6	0.90	0.90	37	5.4	7		
200	³⁾ M3BM	355 LKB 3GBM	351820-•RB	2980	95.3	95.1	0.91	0.91	40	5.4	7		
224	³⁾ M3BM	355 LKC 3GBM	351830-•RB	2980	95.5	95.4	0.91	0.92	45	5.4	7		
250	³⁾ M3BM	355 LKD 3GBM	351840-•RB	2980	95.7	95.7	0.91	0.92	50	5.4	8		
265	³⁾ M3BM	355 LKE 3GBM	351850-•RB	2978	95.7	95.7	0.91	0.92	53	5.4	8		
280	³⁾ M3BM	400 LKA 3GBM	401810-•RB	2982	95.7	95.6	0.91	0.91	56	5.4	10		
315	³⁾ M3BM	400 LKB 3GBM	401820-•RB	2982	96.0	95.8	0.90	0.90	64	5.4	12		
355	³⁾ M3BM	400 LKC 3GBM	401830-•RB	2983	96.2	96.2	0.91	0.91	71	5.4	12		
400	³⁾ M3BM	400 LKD 3GBM	401840-•RB	2983	96.5	96.5	0.92	0.92	79	5.4	11		
450	³⁾ M3BM	400 LKE 3GBM	401850-•RB	2982	96.6	96.6	0.92	0.93	89	5.4	12		
500	³⁾ M3BM	450 LA 3GBM	451510-•RB	2985	96.7	96.6	0.90	0.91	101	5.4	16		
560	³⁾ M3BM	450 LB 3GBM	451520-•RB	2985	96.8	96.8	0.90	0.91	112	5.5	18		
3000 r/min = 2 poles			6600 V 50 Hz										
224	³⁾ M3BM	400 LKA 3GBM	401810-•SB	2982	95.2	94.9	0.88	0.88	23	5.5	5		
250	³⁾ M3BM	400 LKB 3GBM	401820-•SB	2982	95.4	95.1	0.88	0.88	26	5.4	5		
280	³⁾ M3BM	400 LKC 3GBM	401830-•SB	2982	95.5	95.4	0.91	0.91	28	5.4	5		
315	³⁾ M3BM	400 LKD 3GBM	401840-•SB	2982	95.6	95.6	0.91	0.91	32	5.4	5		
355	³⁾ M3BM	400 LKE 3GBM	401850-•SB	2982	95.9	96.0	0.91	0.92	36	5.4	5		
400	³⁾ M3BM	400 LKF 3GBM	401860-•SB	2982	96.2	96.3	0.91	0.93	40	5.4	6		
450	³⁾ M3BM	450 LA 3GBM	451510-•SB	2985	96.4	96.3	0.90	0.91	45	5.4	8		
500	³⁾ M3BM	450 LB 3GBM	451520-•SB	2984	96.6	96.5	0.90	0.91	50	5.3	8		

¹⁾ **355LK:** The given values of load inertia assume two starts from cold and one start from warm conditions in succession against quadratic load torque with 75% of the rated torque at the rated speed and at 80% of the rated voltage.

400LK, 450L: The given values of load inertia assume two starts from cold and one start from warm conditions in succession against quadratic load torque with 70% of the rated torque at the rated speed and at 80% of the rated voltage.

To check validity against other starting requirements, contact ABB.

²⁾ **355LK:** Starting time with given values of the load inertia from cold condition in succession against quadratic load torque with 75% of the rated torque at the rated speed and at rated voltage.

400LK, 450L: Starting time with given values of the load inertia from cold condition in succession against quadratic load torque with 70% of the rated torque at the rated speed and at rated voltage.

³⁾ Unidirectional fan construction as standard. Direction of rotation must be stated when ordering, see variant codes 044 and 045.

⁴⁾ The sound pressure levels are presented at no-load. The magnetic noise level of 2- and 4-pole motors is typically low compared to the fan noise, resulting no increase in the noise level on-load. The variation and measuring tolerance of the figures is +3 dB(A).

6

The bullet in the product code indicates choice of mounting arrangement (see ordering information page).

HV Process performance cast iron motors

Technical data for totally enclosed squirrel cage three phase motors

IP 55 - IC 411 - Insulation class F, temperature rise class B, ambient temperature 50°C

Output kW	Motor type	Torque			Power factor $\cos \varphi_k$	Load inertia ¹⁾ kgm ²	Starting time cold ²⁾ s	Maximum stalling time hot s	Rotor inertia kgm ²	Rotor weight kg	Motor weight kg	Sound pressure level LP ⁴⁾ dB(A)
		T _N Nm	T _s T _N	T _{max} T _N								
3000 r/min = 2 poles		3300 V 50 Hz										
180 ³⁾	M3BM 355 LKA	577	0.5	2.5	0.11	13	14	20	3.2	290	1750	78
200 ³⁾	M3BM 355 LKB	641	0.6	2.5	0.11	15	14	20	3.9	340	1990	78
224 ³⁾	M3BM 355 LKC	718	0.6	2.5	0.10	16	13	20	4.8	360	2080	78
250 ³⁾	M3BM 355 LKD	801	0.6	2.5	0.10	18	13	20	5.5	390	2220	78
265 ³⁾	M3BM 355 LKE	850	0.6	2.4	0.10	19	13	20	5.5	390	2220	78
280 ³⁾	M3BM 400 LKA	897	0.4	2.5	0.09	20	18	25	5.6	430	2450	79
315 ³⁾	M3BM 400 LKB	1009	0.5	2.5	0.09	22	16	25	6.0	440	2510	79
355 ³⁾	M3BM 400 LKC	1137	0.5	2.5	0.09	24	15	25	7.6	500	2750	79
400 ³⁾	M3BM 400 LKD	1281	0.6	2.5	0.09	27	14	20	10.0	570	3100	79
450 ³⁾	M3BM 400 LKE	1441	0.6	2.4	0.10	30	14	20	10.8	600	3200	79
500 ³⁾	M3BM 450 LA	1600	0.8	2.3	0.11	32	12	20	16.8	780	4410	80
560 ³⁾	M3BM 450 LB	1792	0.8	2.4	0.11	36	11	20	18.0	820	4570	80
3000 r/min = 2 poles		6600 V 50 Hz										
224 ³⁾	M3BM 400 LKA	717	0.8	2.4	0.13	16	12	20	7.3	480	2530	79
250 ³⁾	M3BM 400 LKB	801	0.8	2.4	0.12	18	11	20	6.4	480	2530	79
280 ³⁾	M3BM 400 LKC	897	0.5	2.5	0.10	20	17	25	6.7	460	2500	79
315 ³⁾	M3BM 400 LKD	1009	0.5	2.5	0.10	19	14	20	6.7	460	2510	79
355 ³⁾	M3BM 400 LKE	1137	0.5	2.5	0.10	24	15	20	7.7	510	2740	79
400 ³⁾	M3BM 400 LKF	1281	0.6	2.4	0.10	27	14	20	10.4	580	3090	79
450 ³⁾	M3BM 450 LA	1440	0.7	2.3	0.11	30	13	20	15.0	740	4130	80
500 ³⁾	M3BM 450 LB	1600	0.8	2.3	0.11	32	12	20	16.8	780	4350	80

HV Process performance cast iron motors

Technical data for totally enclosed squirrel cage three phase motors

IP 55 - IC 411 - Insulation class F, temperature rise class B, ambient temperature 50°C

Output kW	Motor type	Product code	Speed r/min	Efficiency		Power factor		Current			
				Full load 100%	3/4 load 75%	Full load 100%	3/4 load 75%	I _N A	I _S / I _N	I ₀ A	
1500 r/min = 4 poles				3300 V 50 Hz							
132	M3BM	315 LKA 3GBM	312810-•RB	1486	94.8	94.7	0.85	0.83	29	5.3	10
140	M3BM	315 LKB 3GBM	312820-•RB	1486	95.0	94.9	0.85	0.83	30	5.4	10
160	M3BM	315 LKC 3GBM	312830-•RB	1485	95.1	95.1	0.85	0.83	34	5.2	11
180	M3BM	355 LKA 3GBM	352810-•RB	1490	95.2	94.9	0.83	0.79	40	5.4	15
200	M3BM	355 LKB 3GBM	352820-•RB	1490	95.5	95.2	0.84	0.81	44	5.3	15
224	M3BM	355 LKC 3GBM	352830-•RB	1490	95.7	95.5	0.84	0.82	49	5.3	16
250	M3BM	355 LKD 3GBM	352840-•RB	1490	95.9	95.7	0.84	0.82	54	5.4	18
280	M3BM	355 LKE 3GBM	352850-•RB	1490	95.9	95.8	0.85	0.82	60	5.2	20
315	M3BM	355 LKF 3GBM	352860-•RB	1490	96.1	96.0	0.85	0.83	68	5.4	22
335	M3BM	355 LKG 3GBM	352870-•RB	1490	96.3	96.2	0.85	0.83	72	5.7	23
355	M3BM	400 LKA 3GBM	402810-•RB	1489	96.1	96.1	0.85	0.83	76	5.0	23
400	M3BM	400 LKB 3GBM	402820-•RB	1490	96.4	96.3	0.85	0.83	86	5.3	27
450	M3BM	400 LKC 3GBM	402830-•RB	1490	96.6	96.5	0.86	0.84	95	5.4	28
500	M3BM	400 LKD 3GBM	402840-•RB	1490	96.7	96.7	0.86	0.85	105	5.5	29
560	M3BM	450 LA 3GBM	452510-•RB	1491	96.6	96.5	0.86	0.86	117	5.4	31
600	M3BM	450 LB 3GBM	452520-•RB	1491	96.7	96.6	0.87	0.86	125	5.4	32
1500 r/min = 4 poles				6600 V 50 Hz							
224	M3BM	355 LKA 3GBM	352810-•SB	1487	95.5	95.4	0.84	0.82	24	5.4	8
250	M3BM	355 LKB 3GBM	352820-•SB	1487	95.7	95.7	0.85	0.82	27	5.4	9
280	M3BM	400 LKA 3GBM	402810-•SB	1491	95.5	95.3	0.84	0.81	31	5.4	11
315	M3BM	400 LKB 3GBM	402820-•SB	1491	95.7	95.6	0.85	0.82	34	5.3	11
355	M3BM	400 LKC 3GBM	402830-•SB	1490	96.1	96.0	0.86	0.85	37	5.3	11
400	M3BM	400 LKD 3GBM	402840-•SB	1491	96.3	96.3	0.87	0.85	42	5.4	12
450	M3BM	400 LKE 3GBM	402850-•SB	1490	96.4	96.4	0.87	0.86	47	5.3	13
500	M3BM	450 LA 3GBM	452510-•SB	1491	96.4	96.3	0.86	0.85	53	5.4	14
560	M3BM	450 LB 3GBM	452520-•SB	1491	96.6	96.4	0.86	0.85	59	5.4	16

¹⁾ **315LK:** The given values of load inertia assume three starts from cold and two starts from warm conditions in succession against quadratic load torque with 90% of the rated torque at the rated speed and at 80% of the rated voltage.

355LK: The given values of load inertia assume two starts from cold and one start from warm conditions in succession against quadratic load torque with 80% of the rated torque at the rated speed and at 80% of the rated voltage.

400LK, 450L: The given values of load inertia assume two starts from cold and one start from warm conditions in succession against quadratic load torque with 75% of the rated torque at the rated speed and at 80% of the rated voltage.

To check validity against other starting requirements, contact ABB.

²⁾ **315LK:** Starting time with given values of the load inertia from cold condition in succession against quadratic load torque with 90% of the rated torque at the rated speed and at rated voltage.

355LK: Starting time with given values of the load inertia from cold condition in succession against quadratic load torque with 80% of the rated torque at the rated speed and at rated voltage.

400LK, 450L: Starting time with given values of the load inertia from cold condition in succession against quadratic load torque with 75% of the rated torque at the rated speed and at rated voltage.

³⁾ The sound pressure levels are presented at no-load. The magnetic noise level of 2- and 4-pole motors is typically low compared to the fan noise, resulting no increase in the noise level on-load. The variation and measuring tolerance of the figures is +3 dB(A).

The bullet in the product code indicates choice of mounting arrangement (see ordering information page).

HV Process performance cast iron motors

Technical data for totally enclosed squirrel cage three phase motors

IP 55 - IC 411 - Insulation class F, temperature rise class B, ambient temperature 50°C

Output kW	Motor type	Torque			Power factor cos φ_k	Load inertia ¹⁾ kgm ²	Starting time cold ²⁾ s	Maximum stalling time hot s	Rotor inertia kgm ²	Rotor weight kg	Motor weight kg	Sound pressure level LP ³⁾ dB(A)
		T _N Nm	T _S T _N	T _{max} T _N								
1500 r/min = 4 poles		3300 V 50 Hz										
132	M3BM 315 LKA	848	0.8	2.5	0.15	49	11	20	2.0	220	1180	73
140	M3BM 315 LKB	900	0.9	2.5	0.15	52	10	20	2.0	230	1220	73
160	M3BM 315 LKC	1029	0.8	2.4	0.15	58	11	20	2.3	240	1250	73
180	M3BM 355 LKA	1153	1.0	2.4	0.15	65	11	20	5.6	370	1760	74
200	M3BM 355 LKB	1282	1.0	2.4	0.15	71	11	20	6.4	400	1850	74
224	M3BM 355 LKC	1435	1.0	2.3	0.15	79	11	20	7.2	430	1940	74
250	M3BM 355 LKD	1602	1.0	2.4	0.15	87	10	20	8.0	460	2030	74
280	M3BM 355 LKE	1795	1.0	2.3	0.15	97	10	20	8.4	470	2060	74
315	M3BM 355 LKF	2019	1.0	2.3	0.15	107	10	20	9.6	520	2200	74
335	M3BM 355 LKG	2147	1.1	2.4	0.15	113	9	20	10.4	550	2290	74
355	M3BM 400 LKA	2277	0.7	2.2	0.11	119	13	20	9.6	560	2680	79
400	M3BM 400 LKB	2564	0.7	2.3	0.11	132	12	18	12.0	600	2800	79
450	M3BM 400 LKC	2884	0.7	2.3	0.11	147	12	18	11.9	660	3030	79
500	M3BM 400 LKD	3204	0.8	2.3	0.11	161	11	18	18.0	760	3360	79
560	M3BM 450 LA	3586	1.0	2.3	0.13	177	10	20	23.5	970	4280	83
600	M3BM 450 LB	3843	1.0	2.2	0.13	188	10	20	30.7	1070	4590	83
1500 r/min = 4 poles		6600 V 50 Hz										
224	M3BM 355 LKA	1438	1.1	2.3	0.16	79	9	20	4.8	390	2050	74
250	M3BM 355 LKB	1606	1.1	2.3	0.16	87	9	20	5.5	420	2190	74
280	M3BM 400 LKA	1793	1.0	2.4	0.15	97	10	20	9.7	560	2560	79
315	M3BM 400 LKB	2018	0.7	2.3	0.12	107	13	20	9.6	560	2600	79
355	M3BM 400 LKC	2275	0.7	2.3	0.12	119	13	20	13.8	650	2900	79
400	M3BM 400 LKD	2562	0.7	2.4	0.11	132	12	20	16.2	710	3130	79
450	M3BM 400 LKE	2884	0.7	2.3	0.11	147	12	20	17.4	750	3240	79
500	M3BM 450 LA	3202	1.1	2.2	0.15	161	9	20	28.6	1030	4380	83
560	M3BM 450 LB	3586	1.1	2.2	0.15	177	9	20	30.7	1080	4550	83

HV Process performance cast iron motors

Technical data for totally enclosed squirrel cage three phase motors

IP 55 - IC 411 - Insulation class F, temperature rise class B, ambient temperature 50°C

Output kW	Motor type	Product code	Speed r/min	Efficiency		Power factor		Current			
				Full load 100%	3/4 load 75%	Full load 100%	3/4 load 75%	I _N A	I _S A	I ₀ A	
1000 r/min = 6 poles				3300 V 50 Hz							
112	M3BM	315 LKA 3GBM	313810-•RB	990	94.9	95.0	0.79	0.75	26	5.2	11
125	M3BM	315 LKB 3GBM	313820-•RB	990	95.0	95.1	0.79	0.75	29	5.1	13
132	M3BM	315 LKC 3GBM	313830-•RB	991	95.2	95.2	0.78	0.73	31	5.4	14
140	M3BM	355 LKA 3GBM	353810-•RB	993	95.5	95.4	0.78	0.74	33	5.0	14
160	M3BM	355 LKB 3GBM	353820-•RB	993	95.8	95.7	0.79	0.75	37	5.2	16
180	M3BM	355 LKC 3GBM	353830-•RB	993	95.9	95.9	0.78	0.74	42	5.2	18
200	M3BM	355 LKD 3GBM	353840-•RB	993	96.1	96.0	0.79	0.75	46	5.2	20
224	M3BM	355 LKE 3GBM	353850-•RB	993	96.2	96.1	0.79	0.74	52	5.3	22
250	M3BM	355 LKF 3GBM	353860-•RB	992	96.1	96.2	0.79	0.75	58	5.1	24
280	M3BM	355 LKG 3GBM	353870-•RB	993	96.3	96.3	0.79	0.74	65	5.3	28
355	M3BM	400 LKA 3GBM	403810-•RB	994	96.6	96.6	0.81	0.78	79	5.3	30
400	M3BM	400 LKB 3GBM	403820-•RB	994	96.8	96.8	0.81	0.78	89	5.5	34
425	M3BM	400 LKC 3GBM	403830-•RB	993	96.8	96.8	0.82	0.79	94	5.5	34
450	M3BM	450 LA 3GBM	453510-•RB	993	96.6	96.6	0.84	0.83	96	5.4	29
500	M3BM	450 LB 3GBM	453520-•RB	993	96.7	96.7	0.85	0.83	107	5.5	32
560	M3BM	450 LC 3GBM	453530-•RB	993	96.8	96.9	0.85	0.84	119	5.5	34
1000 r/min = 6 poles				6600 V 50 Hz							
150	M3BM	355 LKA 3GBM	353810-•SB	991	95.2	95.1	0.77	0.72	18	5.2	8
160	M3BM	355 LKB 3GBM	353820-•SB	991	95.3	95.2	0.78	0.73	19	5.2	9
180	M3BM	355 LKC 3GBM	353830-•SB	990	95.4	95.4	0.78	0.74	21	5.0	9
200	M3BM	355 LKD 3GBM	353840-•SB	990	95.6	95.6	0.77	0.72	24	5.2	11
280	M3BM	400 LKA 3GBM	403810-•SB	993	96.1	96.1	0.78	0.74	33	5.2	14
315	M3BM	400 LKB 3GBM	403820-•SB	993	96.3	96.3	0.78	0.75	36	5.3	15
355	M3BM	400 LKC 3GBM	403830-•SB	993	96.5	96.4	0.79	0.75	41	5.4	17
375	M3BM	400 LKD 3GBM	403840-•SB	993	96.6	96.5	0.80	0.76	43	5.4	17
400	M3BM	450 LA 3GBM	453510-•SB	994	96.4	96.4	0.84	0.82	43	5.5	14
450	M3BM	450 LB 3GBM	453520-•SB	994	96.5	96.5	0.84	0.83	48	5.3	15
500	M3BM	450 LC 3GBM	453530-•SB	994	96.6	96.7	0.85	0.83	54	5.4	16
530	M3BM	450 LD 3GBM	453540-•SB	993	96.6	96.7	0.85	0.84	56	5.4	16

6 ¹⁾ **315LK, 355LK:** The given values of load inertia assume three starts from cold and two starts from warm conditions in succession against quadratic load torque with 90% of the rated torque at the rated speed and at 80% of the rated voltage.
400LK, 450L: The given values of load inertia assume two starts from cold and one start from warm conditions in succession against quadratic load torque with 80% of the rated torque at the rated speed and at 80% of the rated voltage.
 To check validity against other starting requirements, contact ABB.

²⁾ **315LK, 355LK:** Starting time with given values of the load inertia from cold condition in succession against quadratic load torque with 90% of the rated torque at the rated speed and at rated voltage.

400LK, 450L: Starting time with given values of the load inertia from cold condition in succession against quadratic load torque with 80% of the rated torque at the rated speed and at rated voltage.

³⁾ The sound pressure levels are presented at no-load. Sound level values of 6...8-pole motors at no-load are typically 1...3 dB(A) higher than the corresponding values at no-load. The variation and measuring tolerance of the figures is +3 dB(A).

The bullet in the product code indicates choice of mounting arrangement (see ordering information page).

HV Process performance cast iron motors

Technical data for totally enclosed squirrel cage three phase motors

IP 55 - IC 411 - Insulation class F, temperature rise class B, ambient temperature 50°C

Output kW	Motor type	Torque			Power factor $\cos \varphi_k$	Load inertia ¹⁾ kgm ²	Starting time cold ²⁾ s	Maximum stalling time hot s	Rotor inertia kgm ²	Rotor weight kg	Motor weight kg	Sound pressure level LP ³⁾ dB(A)
		T _N Nm	T _S T _N	T _{max} T _N								
1000 r/min = 6 poles		3300 V 50 Hz										
112	M3BM 315 LKA	1080	1.1	2.3	0.18	113	11	20	3.7	290	1230	65
125	M3BM 315 LKB	1206	1.1	2.3	0.17	125	11	20	3.9	300	1270	65
132	M3BM 315 LKC	1272	1.2	2.5	0.17	131	10	20	4.1	310	1300	65
140	M3BM 355 LKA	1347	0.8	2.2	0.13	139	14	20	5.6	370	1740	70
160	M3BM 355 LKB	1539	0.9	2.3	0.13	157	14	20	6.8	410	1880	70
180	M3BM 355 LKC	1731	0.9	2.3	0.13	175	13	20	7.2	430	1920	70
200	M3BM 355 LKD	1924	0.9	2.3	0.13	192	13	20	8.0	460	2020	70
224	M3BM 355 LKE	2154	0.9	2.3	0.13	213	12	20	8.8	490	2110	70
250	M3BM 355 LKF	2406	0.9	2.2	0.13	236	12	20	9.2	500	2140	70
280	M3BM 355 LKG	2694	0.9	2.3	0.13	261	12	20	10.4	550	2270	70
355	M3BM 400 LKA	3412	1.0	2.3	0.14	324	11	20	23.4	860	3100	75
400	M3BM 400 LKB	3843	1.1	2.4	0.14	360	11	20	22.7	970	3390	75
425	M3BM 400 LKC	4085	1.1	2.2	0.13	380	11	20	22.5	970	3390	75
450	M3BM 450 LA	4327	1.2	2.2	0.16	400	10	20	33.6	1050	4010	78
500	M3BM 450 LB	4807	1.2	2.2	0.16	439	9	20	31.8	1110	4160	78
560	M3BM 450 LC	5385	1.2	2.2	0.16	486	9	20	45.4	1290	4590	78
1000 r/min = 6 poles		6600 V 50 Hz										
150	M3BM 355 LKA	1446	1.0	2.4	0.15	148	11	20	4.8	390	2040	70
160	M3BM 355 LKB	1543	1.0	2.4	0.15	157	11	20	5.0	410	2090	70
180	M3BM 355 LKC	1737	0.9	2.3	0.15	175	12	20	5.3	420	2130	70
200	M3BM 355 LKD	1929	1.0	2.4	0.15	192	11	20	5.7	440	2230	70
280	M3BM 400 LKA	2693	1.0	2.2	0.14	261	11	20	12.0	620	2740	75
315	M3BM 400 LKB	3030	1.1	2.2	0.14	291	11	20	13.8	680	2910	75
355	M3BM 400 LKC	3414	1.1	2.3	0.14	324	10	20	14.2	750	3140	75
375	M3BM 400 LKD	3606	1.1	2.2	0.14	340	10	20	18.6	820	3370	75
400	M3BM 450 LA	3844	1.2	2.2	0.17	360	10	20	30.8	1080	4030	78
450	M3BM 450 LB	4325	1.2	2.2	0.17	400	10	20	39.5	1170	4250	78
500	M3BM 450 LC	4805	1.2	2.2	0.17	439	10	20	43.9	1260	4470	78
530	M3BM 450 LD	5096	1.2	2.2	0.16	463	9	20	43.9	1260	4470	78

HV Process performance cast iron motors

Technical data for totally enclosed squirrel cage three phase motors

IP 55 - IC 411 - Insulation class F, temperature rise class B, ambient temperature 50°C

Output kW	Motor type	Product code	Speed r/min	Efficiency		Power factor		Current			
				Full load 100%	3/4 load 75%	Full load 100%	3/4 load 75%	I _N A	I _S A	I ₀ A	
750 r/min = 8 poles			3300 V 50 Hz								
160	M3BM	400 LKA 3GBM	404810-•RB	744	95.1	95.0	0.76	0.71	39	5.0	19
180	M3BM	400 LKB 3GBM	404820-•RB	744	95.3	95.2	0.77	0.73	43	4.9	19
200	M3BM	400 LKC 3GBM	404830-•RB	744	95.5	95.4	0.78	0.73	47	5.0	21
224	M3BM	400 LKD 3GBM	404840-•RB	744	95.6	95.5	0.78	0.74	53	5.3	23
250	M3BM	400 LKE 3GBM	404850-•RB	745	95.8	95.7	0.78	0.73	59	5.5	26
280	M3BM	400 LKF 3GBM	404860-•RB	745	96.0	95.9	0.78	0.74	65	5.4	29
315	M3BM	400 LKG 3GBM	404870-•RB	744	96.0	95.9	0.78	0.74	73	5.4	33
355	M3BM	450 LA 3GBM	454510-•RB	745	96.3	96.1	0.79	0.75	82	5.4	35
400	M3BM	450 LB 3GBM	454520-•RB	745	96.4	96.2	0.79	0.74	92	5.5	40
450	M3BM	450 LC 3GBM	454530-•RB	745	96.4	96.3	0.79	0.74	104	5.5	45
750 r/min = 8 poles			6600 V 50 Hz								
160	M3BM	400 LKA 3GBM	404810-•SB	744	94.8	94.6	0.75	0.70	20	5.0	10
180	M3BM	400 LKB 3GBM	404820-•SB	744	95.0	94.9	0.76	0.71	22	5.0	10
200	M3BM	400 LKC 3GBM	404830-•SB	744	95.3	95.1	0.76	0.71	24	5.1	12
224	M3BM	400 LKD 3GBM	404840-•SB	744	95.4	95.3	0.76	0.70	27	5.3	13
250	M3BM	400 LKE 3GBM	404850-•SB	744	95.5	95.4	0.76	0.71	30	5.3	15
280	M3BM	400 LKF 3GBM	404860-•SB	744	95.6	95.4	0.75	0.69	34	5.4	17
315	M3BM	450 LA 3GBM	454510-•SB	745	95.9	95.8	0.79	0.75	36	5.4	16
355	M3BM	450 LB 3GBM	454520-•SB	745	96.1	95.9	0.79	0.75	41	5.4	17
400	M3BM	450 LC 3GBM	454530-•SB	745	96.2	96.1	0.79	0.75	46	5.3	19

¹⁾ **400LK**: The given values of load inertia assume three starts from cold and two starts from warm conditions in succession against quadratic load torque with 90% of the rated torque at the rated speed and at 80% of the rated voltage.

450L: The given values of load inertia assume two starts from cold and one start from warm conditions in succession against quadratic load torque with 85% of the rated torque at the rated speed and at 80% of the rated voltage.

To check validity against other starting requirements, contact ABB.

²⁾ **400LK**: Starting time with given values of the load inertia from cold condition in succession against quadratic load torque with 90% of the rated torque at the rated speed and at rated voltage.

450L: Starting time with given values of the load inertia from cold condition in succession against quadratic load torque with 85% of the rated torque at the rated speed and at rated voltage.

³⁾ The sound pressure levels are presented at no-load. Sound level values of 6...8-pole motors at no-load are typically 1...3 dB(A) higher than the corresponding values at no-load. The variation and measuring tolerance of the figures is +3 dB(A).

The bullet in the product code indicates choice of mounting arrangement (see ordering information page).

HV Process performance cast iron motors

Technical data for totally enclosed squirrel cage three phase motors

IP 55 - IC 411 - Insulation class F, temperature rise class B, ambient temperature 50°C

Output kW	Motor type	Torque			Power factor $\cos \varphi_k$	Load inertia ¹⁾ kgm ²	Starting time cold ²⁾ s	Maximum stalling time hot s	Rotor inertia kgm ²	Rotor weight kg	Motor weight kg	Sound pressure level LP ³⁾ dB(A)
		T _N Nm	T _S T _N	T _{max} T _N								
750 r/min = 8 poles		3300 V 50 Hz										
160	M3BM 400 LKA	2052	1.0	2.1	0.17	315	13	20	12.6	590	2400	75
180	M3BM 400 LKB	2310	1.0	2.1	0.17	352	14	20	14.4	640	2520	75
200	M3BM 400 LKC	2566	1.1	2.1	0.17	388	13	20	14.7	690	2640	75
224	M3BM 400 LKD	2873	1.1	2.2	0.17	430	12	20	20.7	800	2910	75
250	M3BM 400 LKE	3206	1.2	2.3	0.17	476	11	20	24.3	900	3140	75
280	M3BM 400 LKF	3591	1.2	2.2	0.17	528	11	20	26.1	950	3280	75
315	M3BM 400 LKG	4041	1.2	2.2	0.17	587	11	20	27.9	990	3380	75
355	M3BM 450 LA	4548	1.2	2.2	0.16	655	12	20	34.4	1180	4280	76
400	M3BM 450 LB	5125	1.2	2.3	0.16	730	11	20	42.4	1240	4430	76
450	M3BM 450 LC	5766	1.2	2.3	0.16	811	11	20	46.8	1330	4660	76
750 r/min = 8 poles		6600 V 50 Hz										
160	M3BM 400 LKA	2054	1.0	2.3	0.17	315	13	20	10.8	590	2600	75
180	M3BM 400 LKB	2312	1.0	2.2	0.17	352	14	20	12.6	650	2770	75
200	M3BM 400 LKC	2568	1.0	2.3	0.16	388	13	20	14.4	710	2950	75
224	M3BM 400 LKD	2876	1.1	2.3	0.16	430	12	20	16.8	780	3180	75
250	M3BM 400 LKE	3210	1.1	2.3	0.16	476	12	20	18.0	820	3300	75
280	M3BM 400 LKF	3596	1.1	2.4	0.16	528	11	20	18.6	840	3360	75
315	M3BM 450 LA	4035	1.2	2.2	0.16	587	12	20	36.6	1120	4070	76
355	M3BM 450 LB	4548	1.2	2.2	0.16	655	12	20	34.4	1180	4220	76
400	M3BM 450 LC	5126	1.2	2.2	0.16	730	12	20	37.7	1270	4450	76

HV Process performance cast iron motors - Variant codes

Code 1)	Variant	Motor size			
		315	355	400	450
Balancing					
423	Balanced without key	P	P	P	P
424	Full key balancing.	P	P	P	P
Bearings and lubrication					
036	Transport lock for bearings.	P	P	P	P
037	Roller bearing at D-end.	P	P	P	P
107	Bearing mounted PT100 resistance elements.	P	P	P	P
178	Stainless steel/acid proof bolts.	P	P	P	P
398	Motor designed for ambient temperature -20°C to -40°C	P	P	P	P
651	Dial type thermometers (2 pcs) for bearings, without contacts	P	P	P	P
652	Dial type thermometers (2 pcs) for bearings, with contacts	P	P	P	P
654	Provision for vibration sensors (M8x1)	P	P	P	P
Cooling system					
044	Unidirectional fan, clockwise seen from D-end.	NA	P	P	P
045	Unidirectional fan, counter clockwise seen from D-end.	NA	P	P	P
068	Metal fan.	P	P	P	P
Coupling					
035	Assembly of customer supplied coupling-half.	P	P	P	P
Drain holes					
065	Plugged existing drain holes.	P	P	P	P
448	Draining holes with metal plugs.	P	P	P	P
Hazardous environments					
See catalogue "Motors for Hazardous Environments", BU/Ex-motors GB, for details.					
Heating elements					
450	Heating element, 100-120 V.	P	P	P	P
451	Heating element, 200-240 V.	P	P	P	P
Painting					
114	Special paint colour, standard grade.	P	P	P	P
751	Paint system 2, UV-light.	P	P	P	P
Surface treatment acc. to the ISO 12944, category 3 with direct UV radiation.					
752	Paint system 4, offshore.	P	P	P	P
Surface treatment acc. to the ISO 12944, category C5 & Norsok M-501.					
Protection					
005	Protective roof, vertical motor, shaft down.	P	P	P	P
401	Protective roof, horizontal motor.	R	R	R	R
158	Degree of protection IP 65.	P	P	P	P
403	Degree of protection IP 56.	P	P	P	P
Rating & instruction plates					
002	Restamping output and voltage, continuous duty.	P	P	P	P
135	Mounting of additional identification plate, stainless	P	P	P	P
Standards and regulations					
010	Fulfilling CSA Safety Certificate.	P	P	P	P
778	GOST Export/Import Certificate (Russia).	P	P	P	P
Stator winding temperature sensors					
653	Pt-100 (12 pcs) inside stator slots	P	P	P	P
Terminal box					
021	Terminal box LHS (seen from D-end).	P	P	P	P
447	Top mounted separate auxiliary box for heating elements.	P	P	P	P
655	No terminal box, three (3) leads out 1.5 m (5 ft)	P	P	P	P
656	No terminal box, six (6) leads out 1.5 m (5 ft)	P	P	P	P
750	Star point terminal box.	P	P	P	P
Testing					
Routine test report included as standard.					
146	Type test with report for motor from specific delivery patch.	P	P	P	P
147	Type test with report for motor from specific delivery patch, customer witnessed.	P	P	P	P
Variable speed drives					
701	Insulated bearing at N-end.	P	P	P	P
Foundation and installation					
Foundation studs					
Sole plates without anchor bolts					
Sole plates with anchor bolts					
Slide rails for belt drives					

1) Certain variant codes cannot be used simultaneously. P = New manufacture only. NA = Not applicable. R = On request.

HV Process performance cast iron motors Sizes 315-450

Dimension drawings

Foot-mounted: IM B3 (IM 1001)

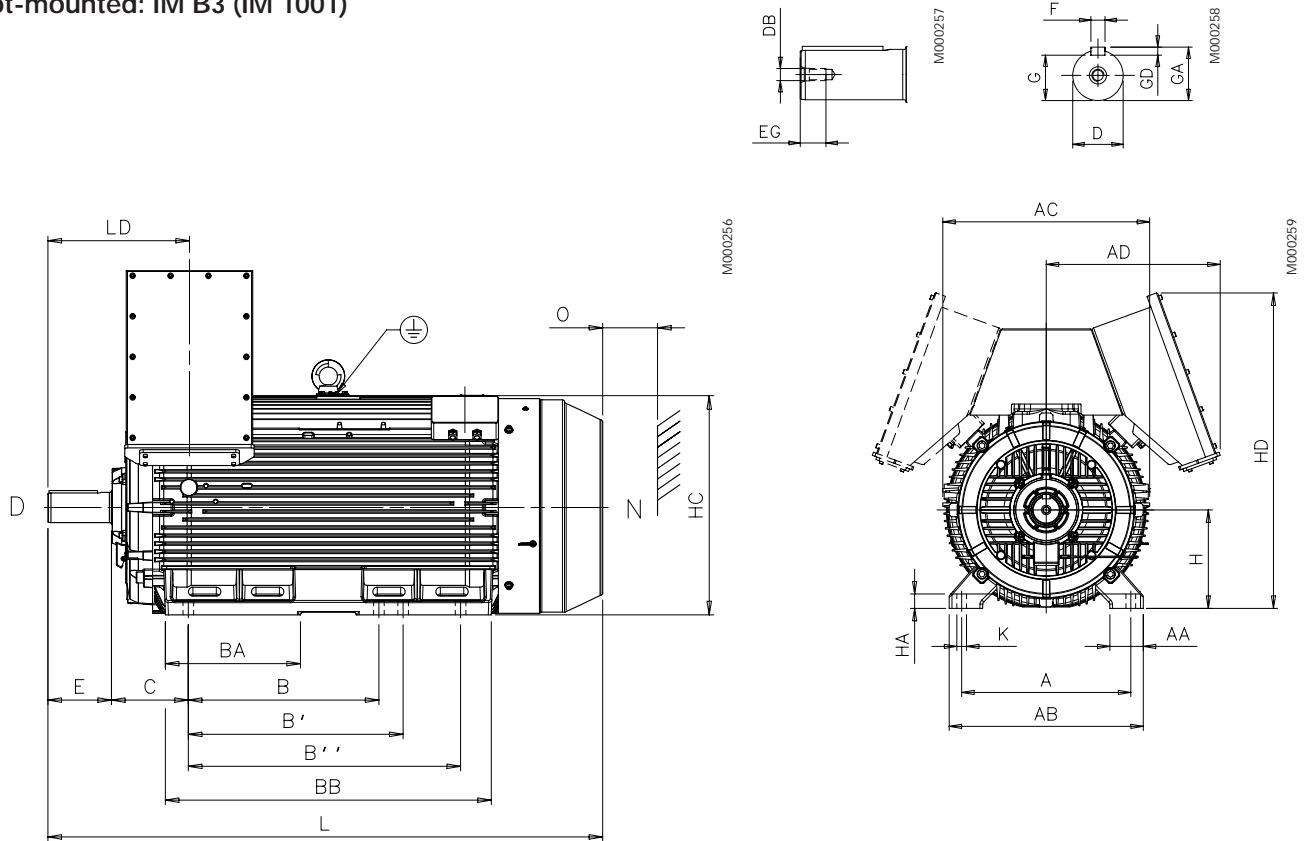

Motor size	Poles	A	AA	AB	AC	AD	AD*	B	B'	B''	BA	BB	C	D	DB	E	EG
315 LK	2	508	100	590	654	555	-	508	560	710	336	851	216	65	M20	140	42
315 LK	4-6	508	100	590	654	555	-	508	560	710	336	851	216	90	M24	170	52
355 LK	2	610	120	700	746	627	-	630	710	900	447	1077	254	70	M20	140	42
355 LK	4-6	610	120	700	746	627	-	630	710	900	447	1077	254	100	M24	210	51
400 L	2	710	150	840	834	627	-	900	1000	-	410	1156	224	80	M20	170	42
400 L	4-8	710	150	840	834	627	-	900	1000	-	410	1156	224	110	M24	210	50
400 LK	2	710	150	840	834	627	-	900	1000	1120	410	1316	224	80	M20	170	42
400 LK	4-8	710	150	840	834	627	-	900	1000	1120	410	1316	224	110	M24	210	50
450 L	2	800	160	950	966	613	790	1000	1120	1250	451	1421	250	80	M20	170	42
450 L	4-8	800	160	950	966	613	790	1000	1120	1250	451	1421	250	120	M24	210	50

Motor size	Poles	F	G	GA	GD	H	HA	HC	HD	HD*	K	L	LD	O
315 LK	2	18	58	69	11	315	40	644	1055	-	28	1490	355	115
315 LK	4-6	25	81	95	14	315	40	644	1055	-	28	1521	385	115
355 LK	2	20	62.5	74.5	12	355	52	725	1138	-	35	1764	398	250
355 LK	4-6	28	90	106	16	355	52	725	1138	-	35	1834	468	130
400 L	2	22	71	85	14	400	45	814	1225	-	35	1851	458	300
400 L	4-8	28	100	116	16	400	45	814	1225	-	35	1891	498	200
400 LK	2	22	71	85	14	400	45	814	1225	-	35	2011	478	300
400 LK	4-8	28	100	116	16	400	45	814	1225	-	35	2051	518	200
450 L	2	22	71	85	14	450	81	933	1378	1502	42	2147	485	300
450 L	4-8	32	109	127	18	450	81	933	1378	1502	42	2187	525	200

* For 10 kV only

Tolerances:

A, B, C	± 0,8	F	ISO h9
D	ISO m6	H	+0 -1.0

Above table gives the main dimensions in mm.

For detailed drawings please see our web-pages 'www.abb.com/motors&drives' or contact us.

HV Process performance cast iron motors Sizes 315-450

Dimension drawings

Flange-mounted; IM V1 (IM 3011)

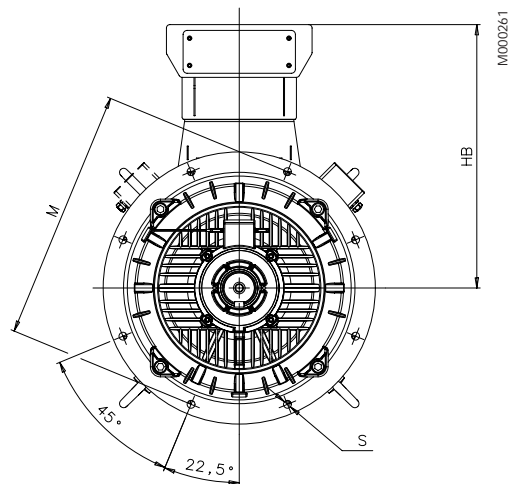
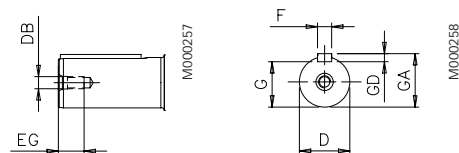
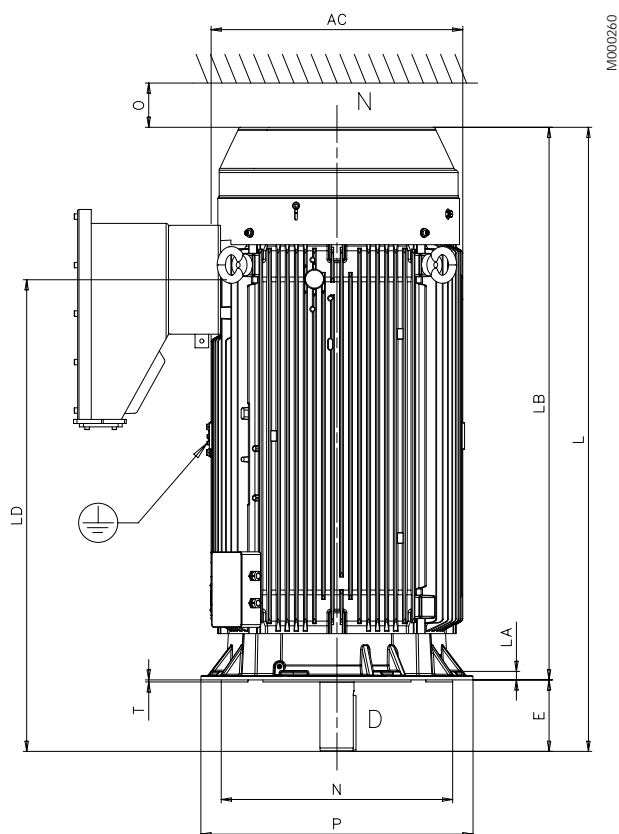

Motor size	Poles	AC	D	DB	E	EG	F	G	GA	GD	HB	HB*
315 LK	4-6	645	90	M24	170	52	25	81	95	14	731	-
355 LK	4-6	740	100	M24	210	51	28	90	106	16	774	-
400 L	4-8	827	110	M24	210	50	28	100	116	16	816	-
400 LK	4-8	810	110	M24	210	50	28	100	116	16	816	-
450 L	4-8	966	120	M24	210	50	32	109	127	18	887	982

Motor size	Poles	L	LA	LB	LD	M	N	O	P	S	T
315 LK	4-6	1521	25	1351	1115	600	550	115	660	23	6
355 LK	4-6	1834	25	1624	1386	740	680	130	800	23	6
400 L	4-8	1891	26	1681	1400	940	880	200	1000	28	6
400 LK	4-8	2051	26	1841	1540	940	880	200	1000	28	6
450 L	4-8	2187	33	1977	1645	1080	1000	200	1149	28	6

* For 10 kV only

Tolerances:

D ISO m6
F ISO h9
N ISO js6 (315_)

Above table gives the main dimensions in mm.

For detailed drawings please see our web-pages 'www.abb.com/motors&drives' or contact us.

HV Process performance cast iron motors Sizes 315-450

Dimension drawings

Foot- and flange-mounted; IM B35 (IM 2001)

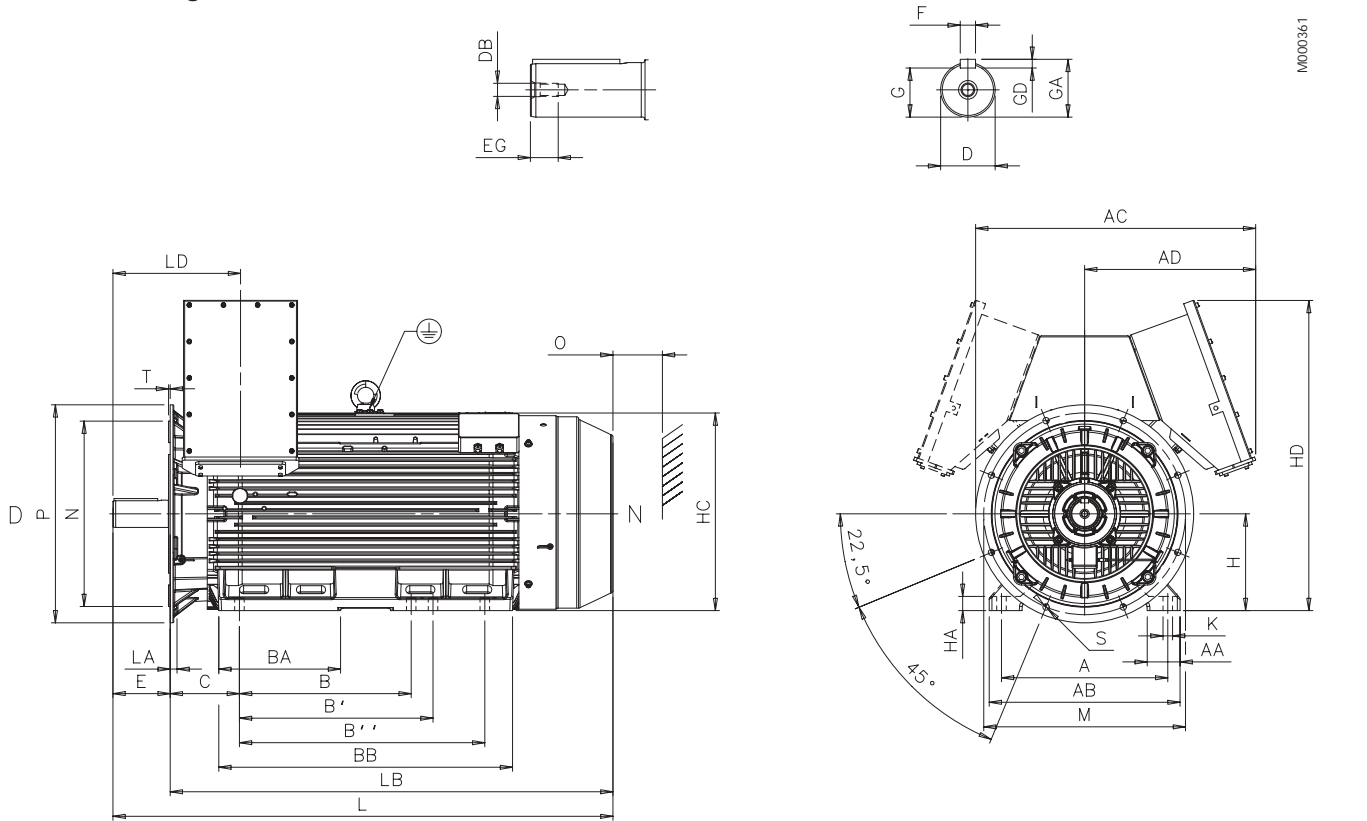

IM000361

Motor size	Poles	A	AA	AB	AC	AD	AD*	B	B'	B''	BA	BB	C	D	DB	E	EG	F	G	GA
315LK	2	508	100	590	885	555	-	508	560	710	336	851	216	65	M20	140	42	18	58	69
315LK	4-6	508	100	590	885	555	-	508	560	710	336	851	216	90	M24	170	52	25	81	95
355LK	2	610	120	700	1027	627	-	630	710	900	447	1077	254	70	M20	140	42	20	62.5	74.5
355LK	4-6	610	120	700	1027	627	-	630	710	900	447	1077	254	100	M24	210	51	28	90	106
400L	2	710	150	840	1127	627	-	900	1000	-	410	1156	224	80	M20	170	42	22	71	85
400L	4-8	710	150	840	1127	627	-	900	1000	-	410	1156	224	110	M24	210	50	28	100	116
400LK	2	710	150	840	1127	627	-	900	1000	1120	410	1316	224	80	M20	170	42	22	71	85
400LK	4-8	710	150	840	1127	627	-	900	1000	1120	410	1316	224	110	M24	210	50	28	100	116
450L	2	800	160	950	1188	613	790	1000	1120	1250	451	1421	250	80	M20	170	42	22	71	85
450L	4-8	800	160	950	1188	613	790	1000	1120	1250	451	1421	250	120	M24	210	50	32	109	127

Motor size	Poles	GD	H	HA	HC	HD	HD*	K	L	LD	O	LA	LB	M	N	P	S	T
315LK	2	11	315	40	643	1055	-	28	1490	355	115	25	1350	600	550	660	23	6
315LK	4-6	14	315	40	643	1055	-	28	1521	385	115	25	1350	600	550	660	23	6
355LK	2	12	355	52	725	1138	-	35	1764	398	250	25	1624	740	680	800	23	6
355LK	4-6	16	355	52	725	1138	-	35	1834	468	130	25	1624	740	680	800	23	6
400L	2	14	400	45	814	1225	-	35	1851	458	300	26	1681	940	880	1000	28	6
400L	4-8	16	400	45	814	1225	-	35	1891	498	200	26	1681	940	880	1000	28	6
400LK	2	14	400	45	814	1225	-	35	2011	478	300	26	1841	940	880	1000	28	6
400LK	4-8	16	400	45	814	1225	-	35	2051	518	200	26	1841	940	880	1000	28	6
450L	2	14	450	81	933	1378	1502	42	2147	485	300	33	1977	1080	1000	1149	28	6
450L	4-8	18	450	81	933	1378	1502	42	2187	525	200	33	1977	1080	1000	1149	28	6

* for 10 kV only

Accessories

Foundation studs

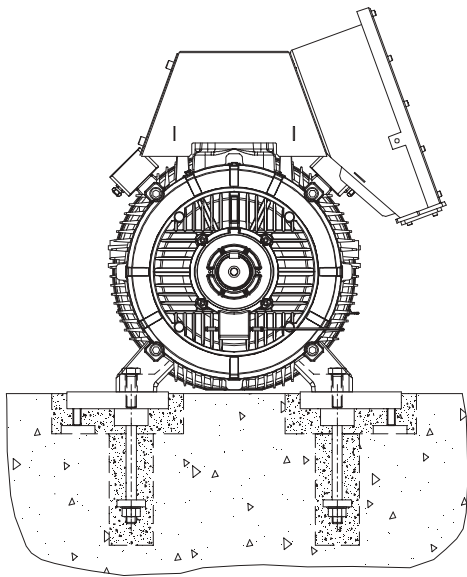

M000262

Frame size	Set code
315	FOST315-M3
355	FOST355-M3
400	FOST400-M3
450	FOST450-M3

The set code has to be mentioned on order.

Slide rails

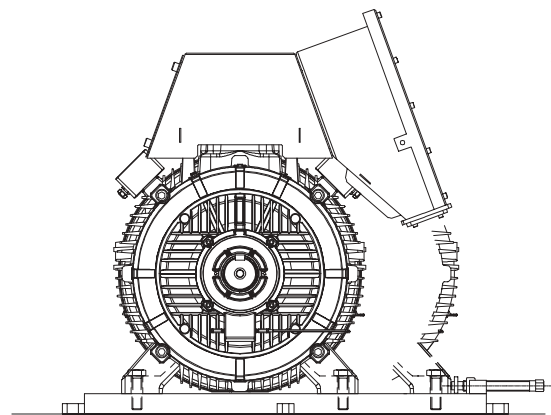

M000263

Frame size	Set code
315	SLRA315-M3
355	SLRA355-M3
400	SLRA400-M3
450	SLRA450-M3

The set code has to be mentioned on order.

Sole plates

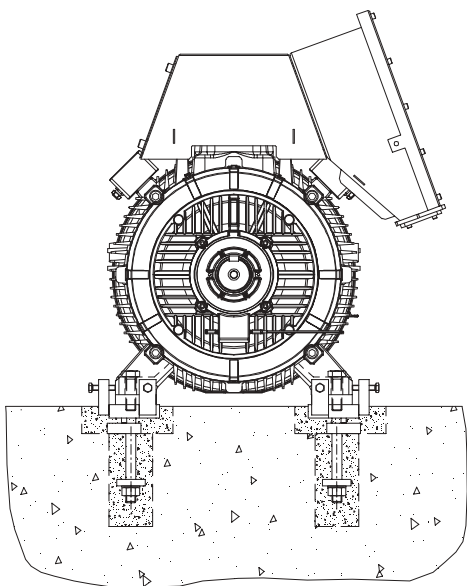

M000327

With anchor bolts for concrete foundation

Frame size	Set code
315	SOPL315A-M3
355	SOPL355A-M3
400 L	SOPL400A-M3
400 LK	SOPL400A-M3LK
450	SOPL450A-M3

The set code has to be mentioned on order.

Sole plates

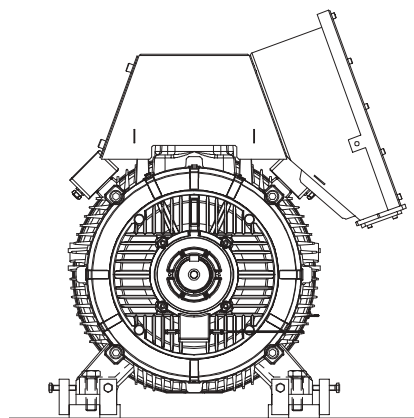

M000327

Without anchor bolts

Frame size	Set code
315	SOPL315-M3
355	SOPL355-M3
400 L	SOPL400-M3
400 LK	SOPL400-M3LK
450	SOPL450-M3

The set code has to be mentioned on order.

Accessories

Protective roof

Variant code 005

Motor size	Pole no	L	LL
315 LK	4-6	1591	1421
355 LK	4-6	1951	1741
400 L	4-6	2008	1798
400 LK	4-6	2168	1958
450 L	4-6	2389	2179

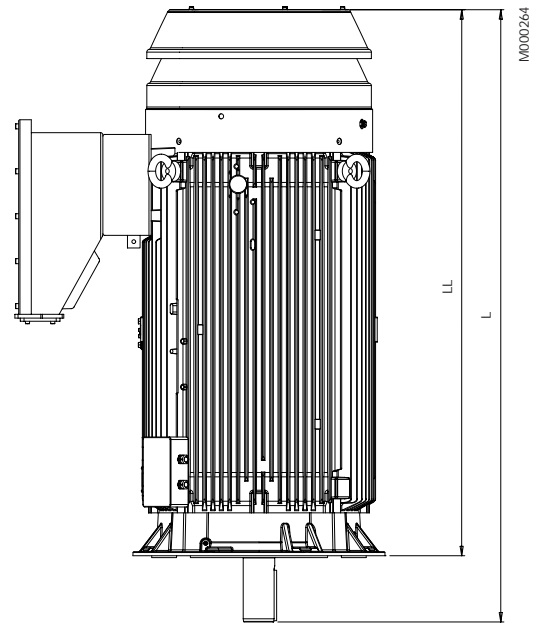

Provision for vibration sensors

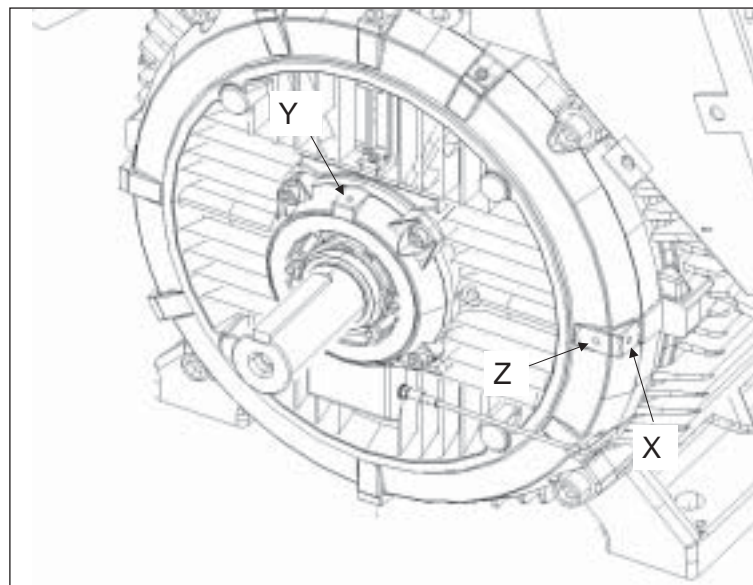

Provision for vibration sensors M8x1. XYZ-directions. Available only for D-end.

HV Process performance cast iron motor construction

Typical exploded view of high voltage cast iron motor

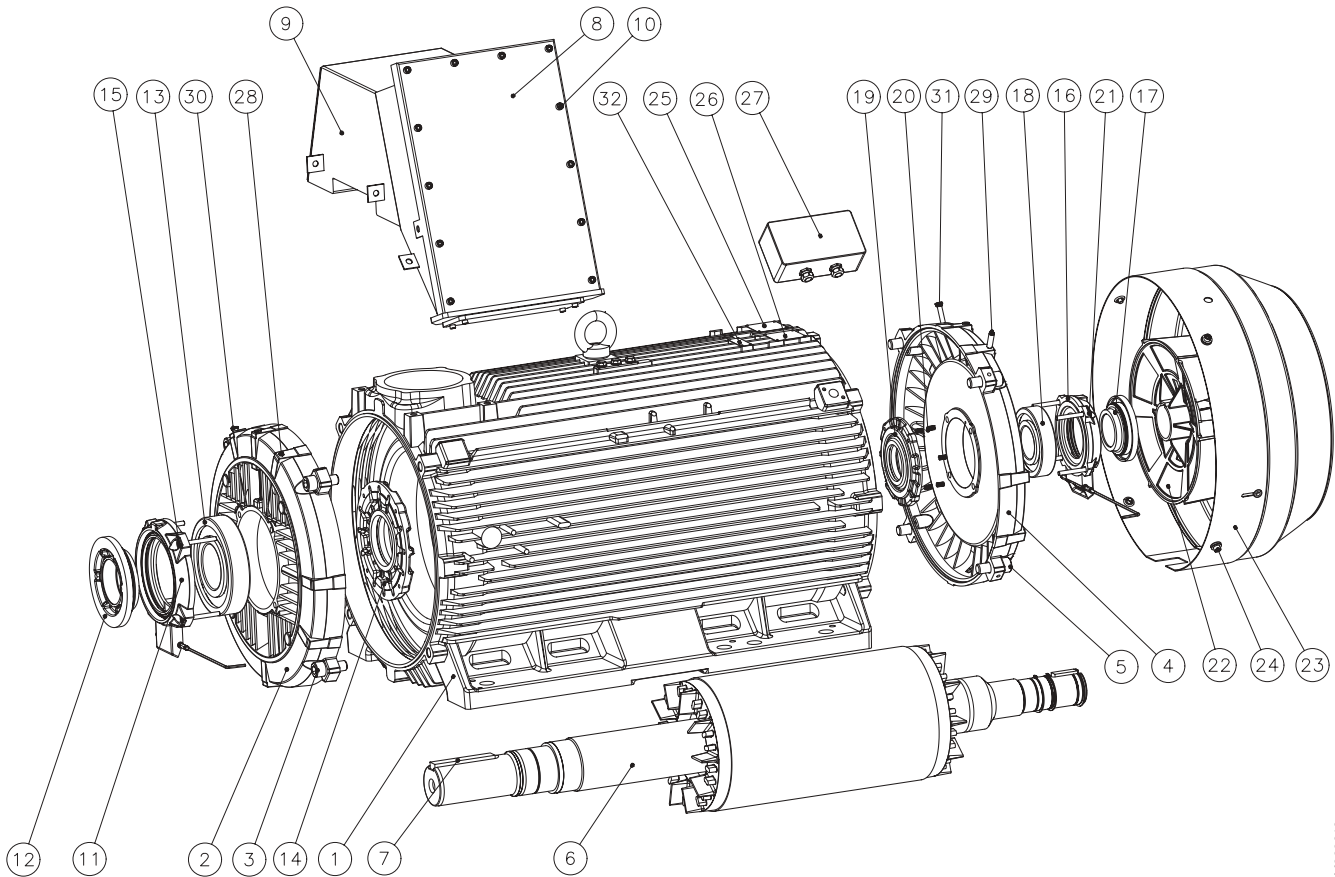

M000363

- | | | | |
|----|---------------------------------------|----|---------------------------------------|
| 1 | Stator frame | 17 | Valve disc with labyrinth seal, D-end |
| 2 | End shield, D-end | 18 | Bearing, N-end |
| 3 | Screws for end shield, D-end | 19 | Inner bearing cover, N-end |
| 4 | End shield, N-end | 20 | Spring |
| 5 | Screws for end shield, N-end | 21 | Screws for bearing cover, N-end |
| 6 | Rotor with shaft | 22 | Fan |
| 7 | Key, D-end | 23 | Fan cover |
| 8 | Main terminal box | 24 | Screws for fan cover |
| 9 | Middle box | 25 | Rating plate |
| 10 | Screws for terminal box cover | 26 | Lubrication plate |
| 11 | Outer bearing cover, D-end | 27 | Auxiliary terminal box |
| 12 | Valve disc with labyrinth seal, D-end | 28 | Grease nipple, D-end |
| 13 | Bearing, D-end | 29 | Grease nipple, N-end |
| 14 | Inner bearing cover | 30 | SPM nipple, D-end |
| 15 | Screws for bearing cover, D-end | 31 | SPM nipple, N-end |
| 16 | Outer bearing cover, N-end | 32 | Additional identification plate |

HV Process performance cast iron motors in brief, basic design

Motor size		315	355	400	450	
Stator	Material	Cast iron EN-GJL-250 EN 1561				
	Paint colour shade	Blue, Munsell 8B 4.5/3.25 / NCS 4822 B05G / RAL 5014				
	Paint thickness	Two-pack epoxy paint, thickness $\geq 180 \mu\text{m}$				
Bearing end shields	Material	Cast iron EN-GJL-200 SFS-EN 1561				
	Paint colour shade	Blue, Munsell 8B 4.5/3.25 / NCS 4822 B05G / RAL 5014				
	Paint thickness	Two-pack epoxy paint, thickness $\geq 180 \mu\text{m}$				
Bearings	D-end	2 pole	6316M/C3	6316M/C3	6317M/C3	6317M/C3
		4-8 pole	6319/C3	6322/C3	6324/C3	6326M/C3
	N-end	2 pole	6316M/C3	6316M/C3	6317M/C3	6317M/C3
		4-8 pole	6316/C3	6316/C3	6319/C3	6322/C3
Axially-locked bearings	Inner bearing cover	As standard, locked at D-end				
Bearing seal		As standard, labyrinth seal in both ends.				
Lubrication		Regreasable bearings Regreasing nipples M10x1 DIN 71412 A				
SPM-nipples		As standard				
Rating and lubrication plate	Material	Stainless steel, EN 10088, thickness 0.5 mm.				
Terminal box	Frame material	Structural steel S235JRG2-EN-10025, thickness 3 mm.				
	Cover material	Structural steel S235JRG2-EN-10025, thickness 3 mm.				
	Cover screws material	Blue passivated.				
Connections	Cable entries	Blind gland plate.				
	Terminals	3 terminals for connection with cable lugs (not included) Grounding locations on frame and terminal box (in- and outside)				
Fan	Material	Glass reinforced polypropylene, aluminum, steel or glass reinforced polyamide fan with metal hub. Direction of rotation / fans (IC411) - glass reinforced polypropylene bidirectional - aluminum birectional - steel bidirectional - glass reinforced polyamide fan unidirectional.				
Fan cover	Material	Steel				
	Paint colour shade	Blue, Munsell 8B 4.5/3.25 / NCS 4822 B05G / RAL 5014				
	Paint thickness	Two-pack epoxy polyester powder, thickness $\geq 80 \mu\text{m}$				
Stator winding	Material	Form wound copper, VPI				
	Insulation	Insulation class F				
	Winding protection	PT100, 6 pieces				
Rotor winding	Material	Pressure die-cast aluminum				
Balancing method		Half key balancing as standard				
Key ways		Open key way				
Heating elements	On request	1x200 W	1x200 W	1x300 W	1x400 W	
Drain holes		Standard, open on delivery.				
Enclosure		IP 55, higher protection as option.				
Cooling method		IC 411				

ABB Motors' total product offer

ABB offers several comprehensive ranges of AC motors and generators. We manufacture synchronous motors for even the most demanding applications, and a full range of low and high voltage induction motors. Our in-depth knowledge of virtually every type of industrial processing ensures we always specify the best solution for your needs.



M000328

Low voltage motors and generators

General purpose motor for standard applications

- Aluminum motors
- Steel motors
- Cast iron motors
- Open drip proof motors
- Global motors
- Brake motors
- Single phase motors
- Servomotors

Process performance motors for more demanding applications

- Aluminum motors
- Cast iron motors (IEC and NEMA)
- Motors for high ambient temperatures
- Permanent magnet motors
- High speed motors
- Wind turbine generators
- Smoke venting motors
- Water cooled motors
- Motors for roller table drives

Motors for hazardous areas

- Flameproof motors
- Increased safety motors
- Non-sparking motors
- Dust ignition proof motors

Marine motors

- Aluminum motors
- Steel motors
- Cast iron motors
- Open drip proof motors

High voltage and synchronous motors and generators

- High voltage cast iron motors
- Induction modular motors
- Slip ring motors
- Motors for hazardous areas
- Synchronous motors and generators
- DC motors and generators